

US00D504654S

(12) **United States Design Patent**  
**Graham et al.**

(10) **Patent No.:** **US D504,654 S**  
(45) **Date of Patent:** **\*\* May 3, 2005**

(54) **AIRCRAFT**

(75) Inventors: **David Herbert Graham**, San Pedro, CA (US); **Domenic J. Maglieri**, Williamsburg, VA (US); **Hideo Ikawa**, Huntington Beach, CA (US); **Jay Lee Vadnais**, Torrance, CA (US); **Keith Brian Meredith**, Carson, CA (US); **Joseph William Pawlowski**, Granada Hills, CA (US); **John Albert Dahlin**, Rancho Palos Verdes, CA (US); **Marvin LeRoy Martin**, Lancaster, CA (US)

(73) Assignee: **Northrop Grumman Corporation**, Los Angeles, CA (US)

(\*\*) Term: **14 Years**

(21) Appl. No.: **29/211,542**

(22) Filed: **Aug. 18, 2004**

(51) **LOC (7) Cl.** ..... **12-12**

(52) **U.S. Cl.** ..... **D12/319**

(58) **Field of Search** ..... D12/319-345;  
244/5, 12, 15, 45 A, 45 R, 52

(56) **References Cited**

**U.S. PATENT DOCUMENTS**

D244,180 S 5/1977 Rosenthal

D257,338 S 10/1980 McComas et al.  
D332,080 S 12/1992 Sandusky, Jr. et al.  
D399,816 S \* 10/1998 Peacock ..... D12/319  
D439,876 S \* 4/2001 Simonov et al. .... D12/319  
D467,533 S \* 12/2002 Han ..... D12/319  
D471,853 S \* 3/2003 Lucchesini ..... D12/319

\* cited by examiner

*Primary Examiner*—Marcus A. Jackson  
(74) *Attorney, Agent, or Firm*—Robert P. Lenart, Esq.;  
Pietragallo, Bosick & Gordon

(57) **CLAIM**

The ornamental design for an aircraft, as shown and described.

**DESCRIPTION**

FIG. 1 is a top perspective view of an aircraft constructed in accordance with this invention.

FIG. 2 is a front view of the aircraft of FIG. 1.

FIG. 3 is a rear view of the aircraft of FIG. 1.

FIG. 4 is a top plan view of the aircraft of FIG. 1.

FIG. 5 is a bottom plan view of the aircraft of FIG. 1.

FIG. 6 is a left side view of the aircraft of FIG. 1; and,

FIG. 7 is a right side view of the aircraft of FIG. 1.

**1 Claim, 7 Drawing Sheets**

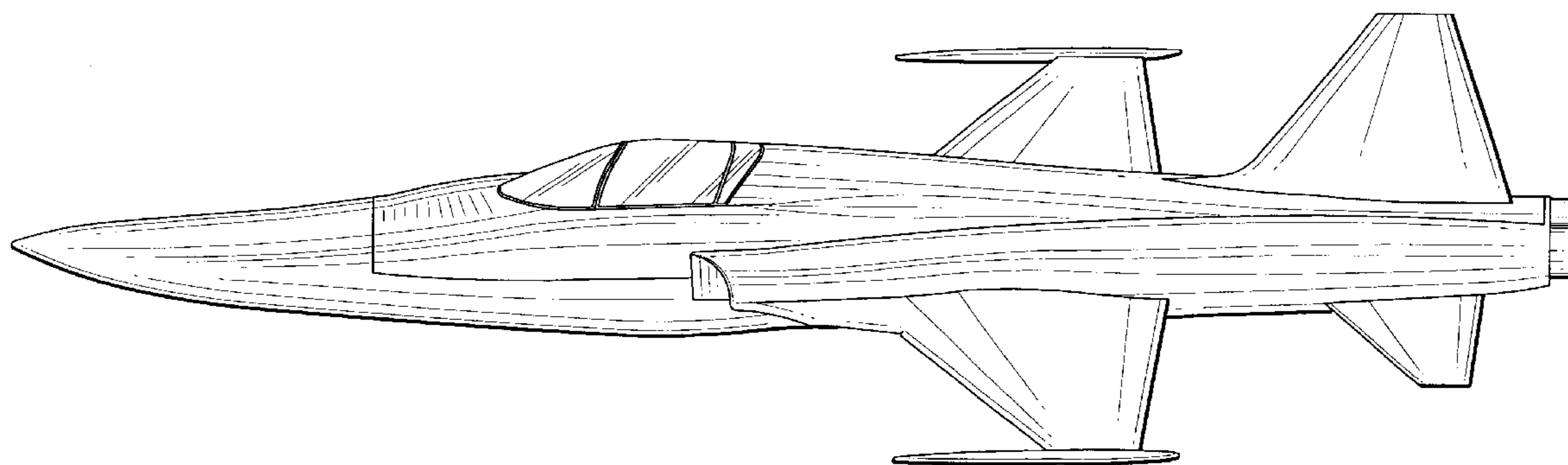

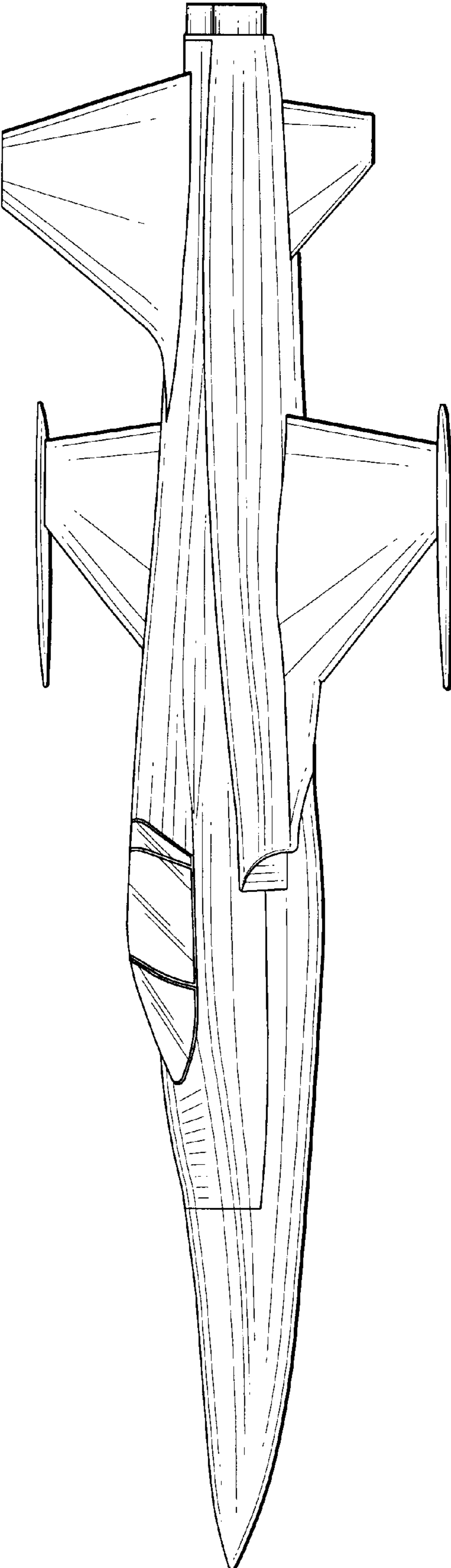

FIG. 1

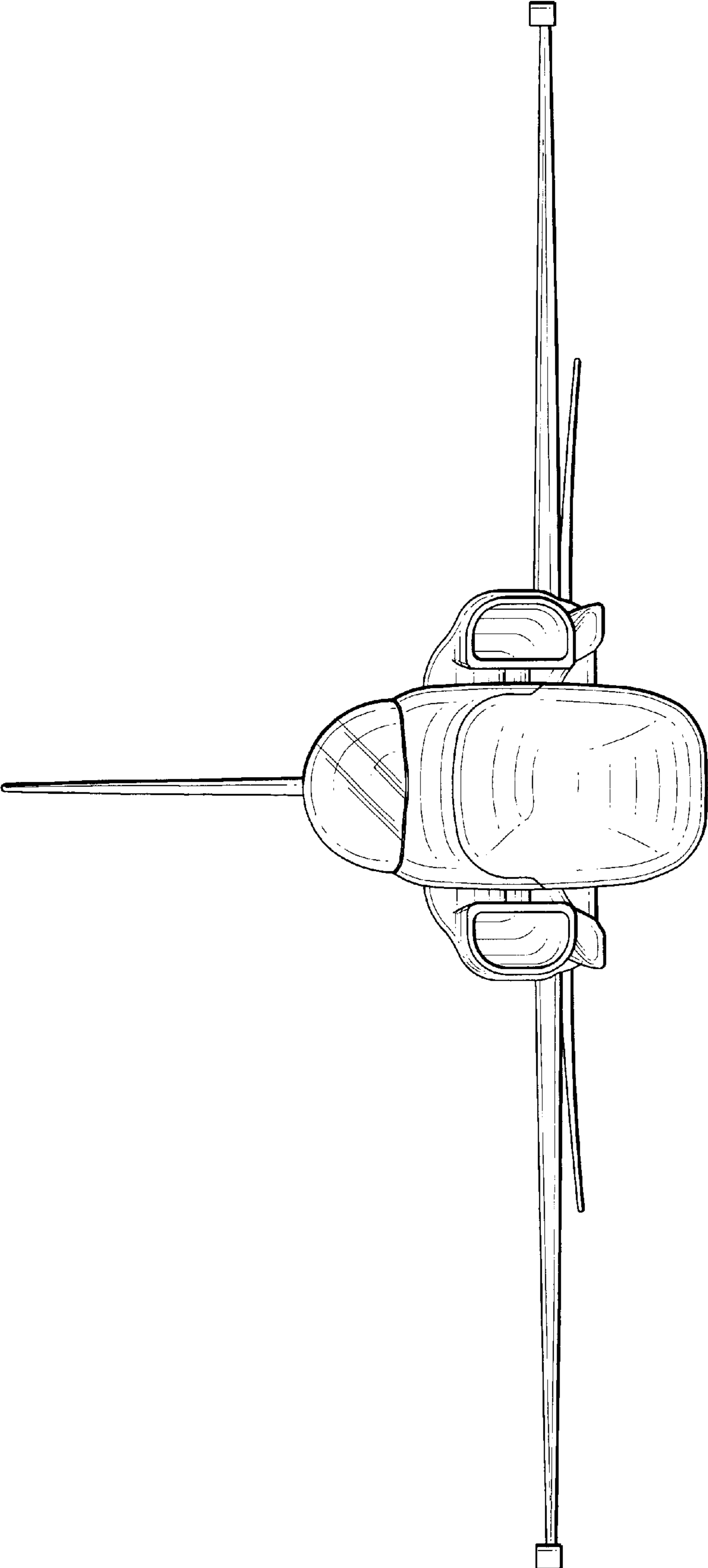

FIG. 2

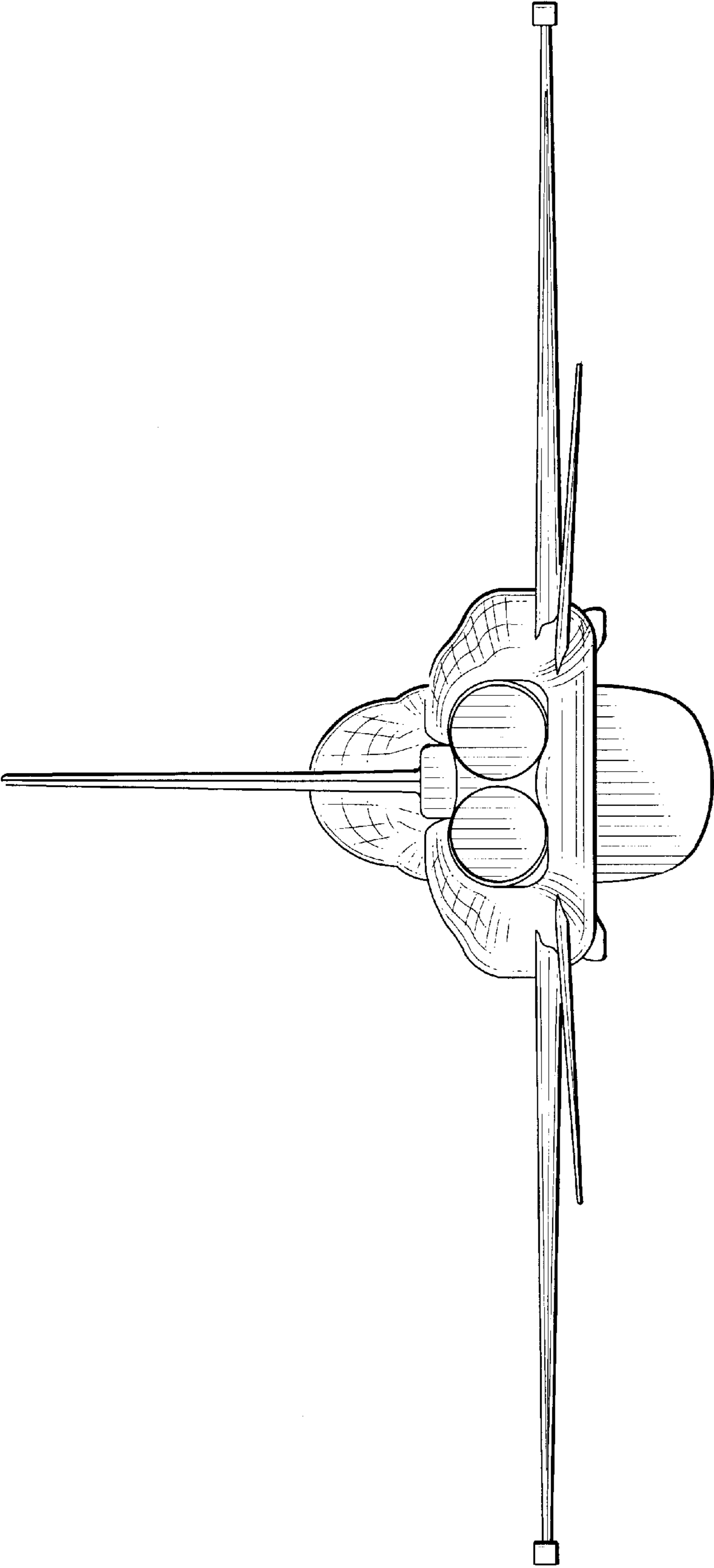

FIG. 3

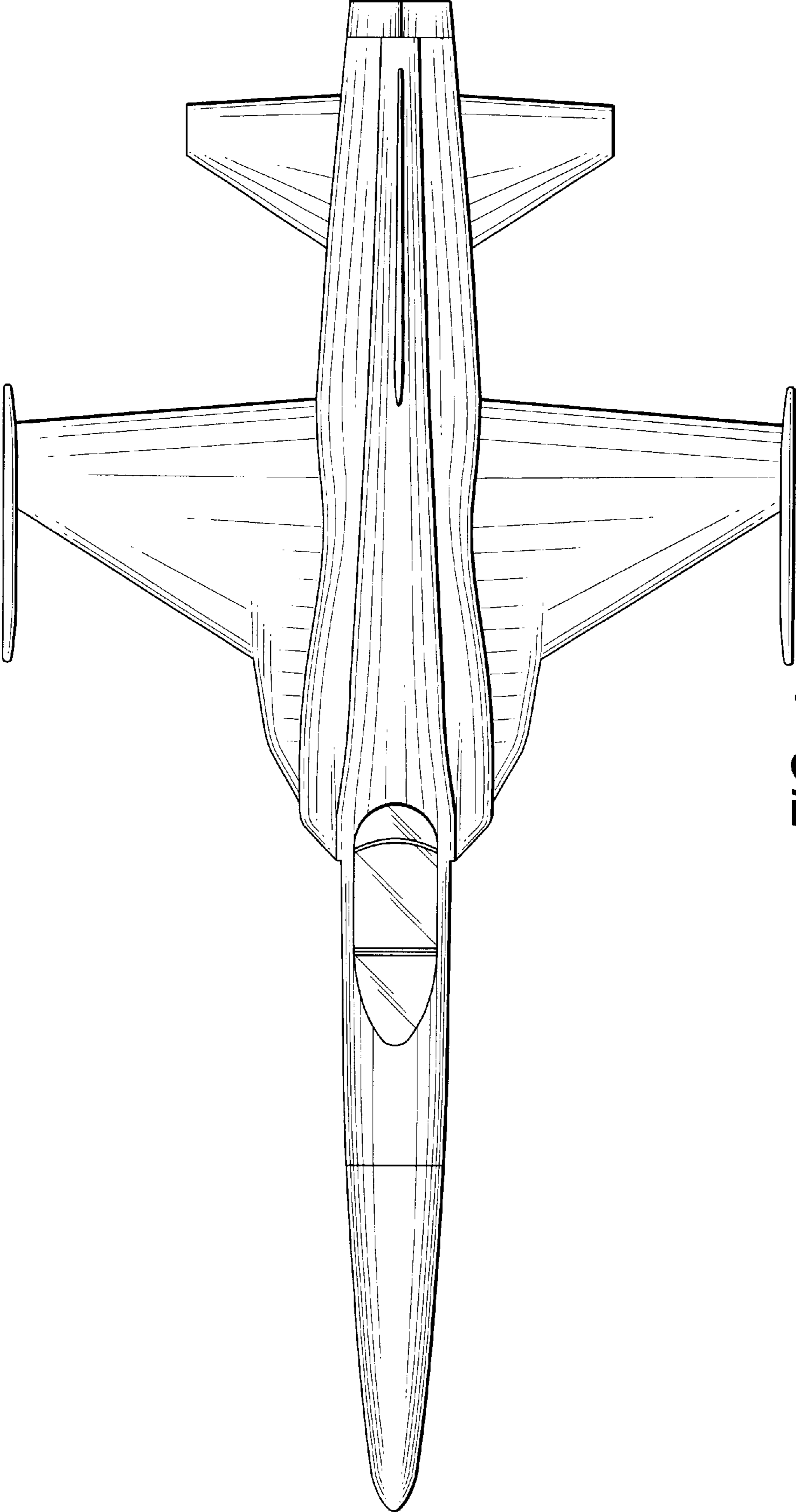

FIG. 4

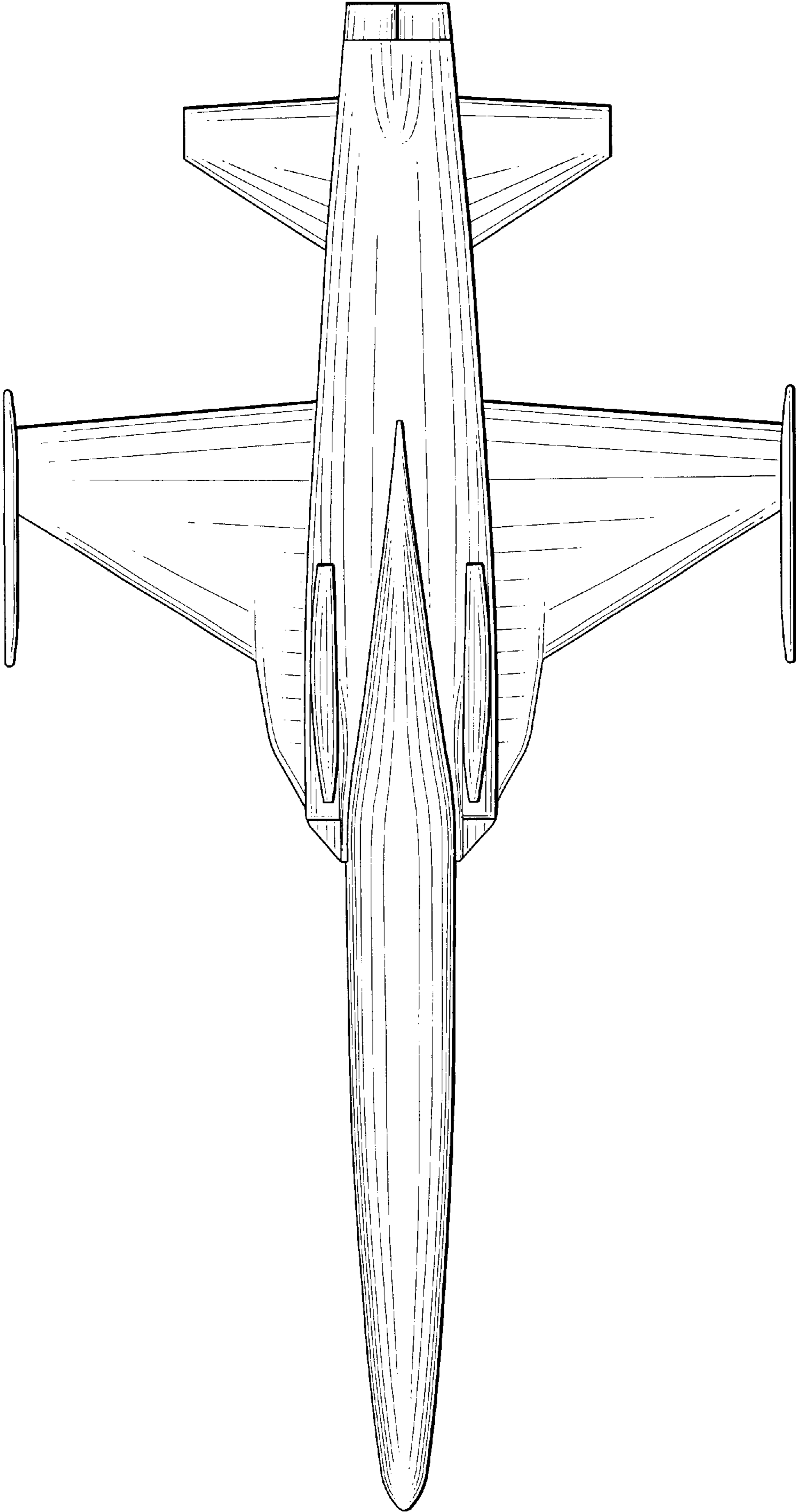

FIG. 5

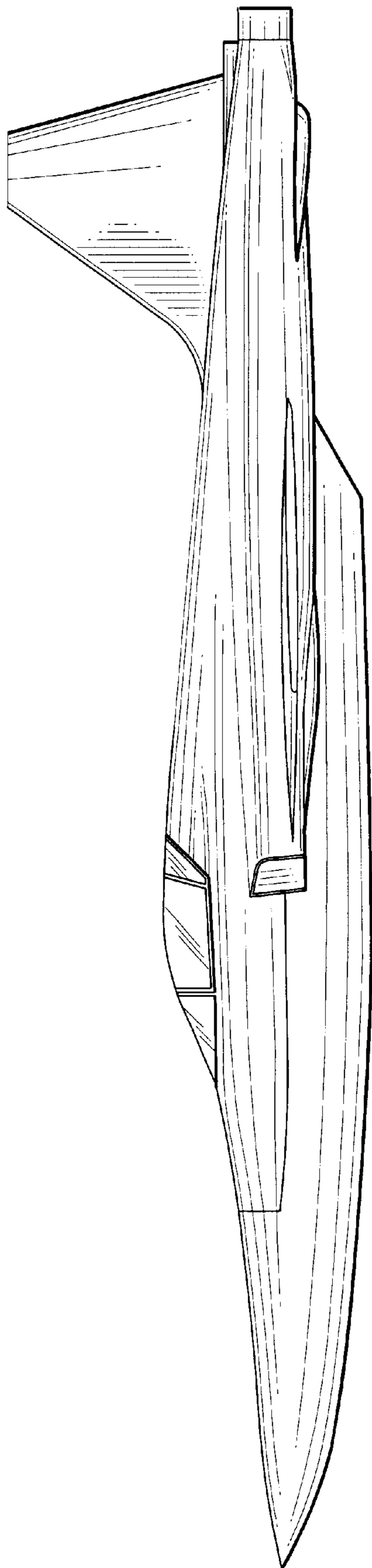

FIG. 6

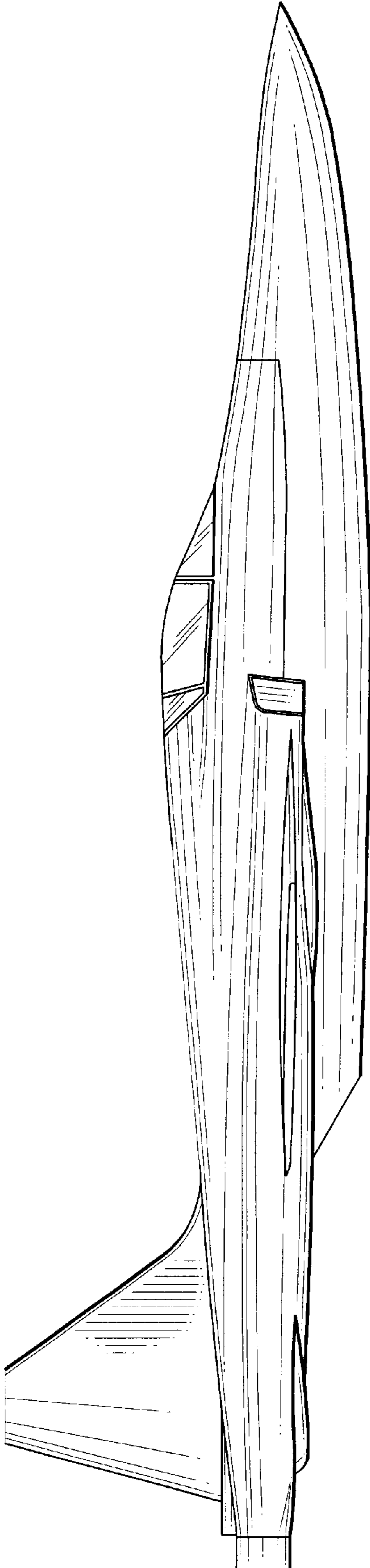

FIG. 7