

US00D504630S

(12) **United States Design Patent**  
**Wang**

(10) **Patent No.:** **US D504,630 S**

(45) **Date of Patent:** **\*\* May 3, 2005**

(54) **TIRE PRESSURE GAUGE**

D472,172 S \* 3/2003 Fujioka et al. .... D10/86

(76) Inventor: **Wei-Chi Wang**, 17-1 Fl., No. 457,  
Cheng-Kung Rd., Tainan (TW)

(\*\*) Term: **14 Years**

(21) Appl. No.: **29/211,153**

(22) Filed: **Aug. 12, 2004**

(30) **Foreign Application Priority Data**

Mar. 19, 2004 (CN) ..... 2004300369719

(51) **LOC (7) Cl.** ..... **10-04**

(52) **U.S. Cl.** ..... **D10/86**

(58) **Field of Search** ..... D10/85, 86, 57;  
73/146.3, 146.8, 744; 116/34 R, 272; 702/140

(56) **References Cited**

**U.S. PATENT DOCUMENTS**

- D212,385 S \* 10/1968 Yamada ..... D10/86
- 4,827,764 A \* 5/1989 Hwang ..... 73/146.8
- 5,435,173 A \* 7/1995 Hwang ..... 73/146.8
- 5,908,984 A \* 6/1999 Chuang ..... 73/146.3
- D440,895 S \* 4/2001 Van Zeyl ..... D10/86
- D462,627 S \* 9/2002 Petrucelli ..... D10/86

**OTHER PUBLICATIONS**

Aerostitch, 2002, p. 140, "Topeak Smart Gauge" tire pressure gauge. Copy in Measuring Testing & Signaling Digest.\*

\* cited by examiner

*Primary Examiner*—Lucy Lieberman

(74) *Attorney, Agent, or Firm*—Hershkovitz & Associates;  
Abe Hershkovitz

(57) **CLAIM**

The ornamental design for a tire pressure gauge, as shown.

**DESCRIPTION**

FIG. 1 is a perspective view of a tire pressure gauge, showing my new design;  
FIG. 2 is a front elevation thereof;  
FIG. 3 is a rear elevation thereof;  
FIG. 4 is a left side elevation thereof;  
FIG. 5 is a right side elevation thereof;  
FIG. 6 is a top plan view thereof; and,  
FIG. 7 is a bottom plan view thereof.

**1 Claim, 3 Drawing Sheets**

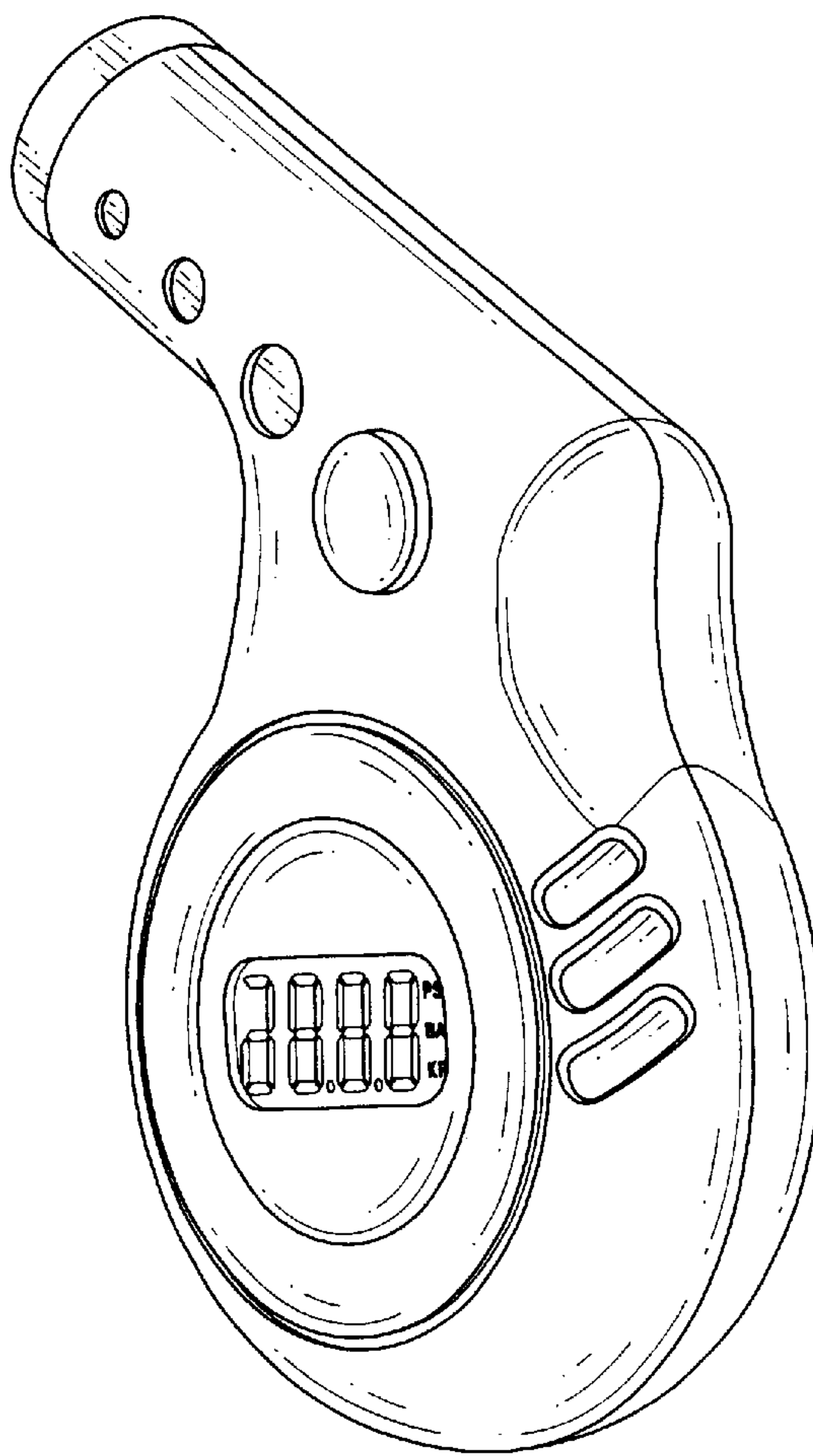

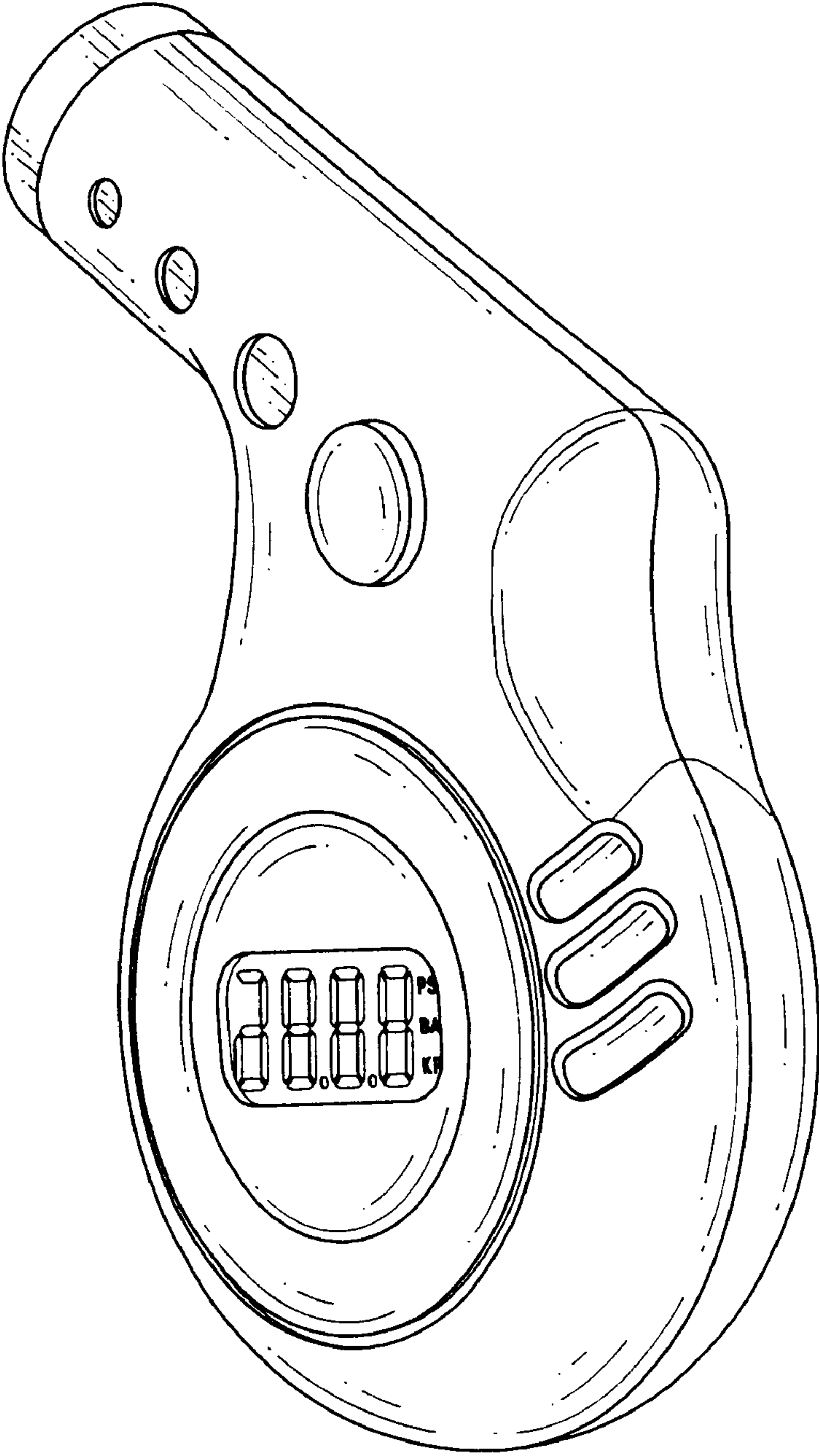

FIG.1

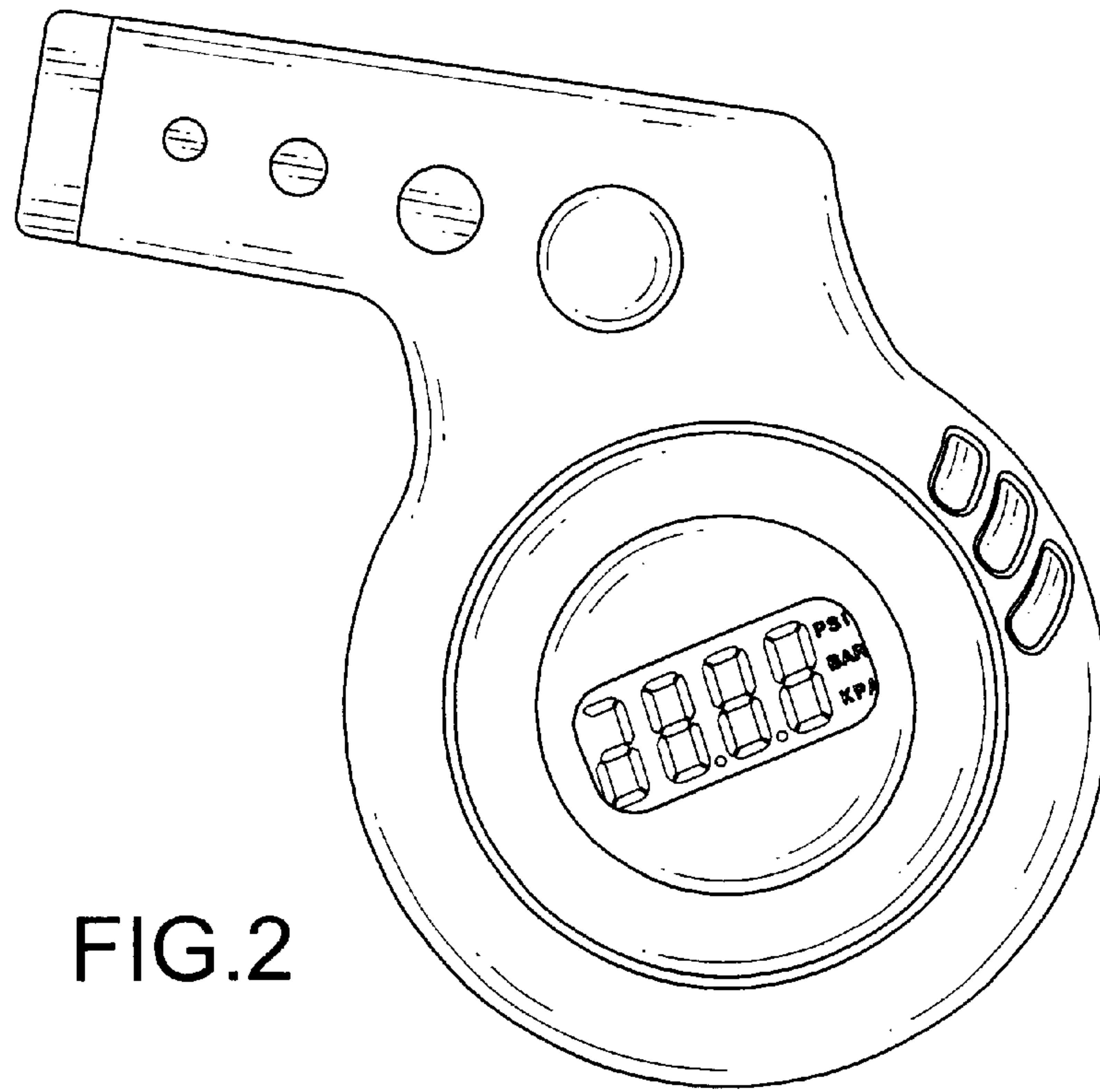

FIG.2

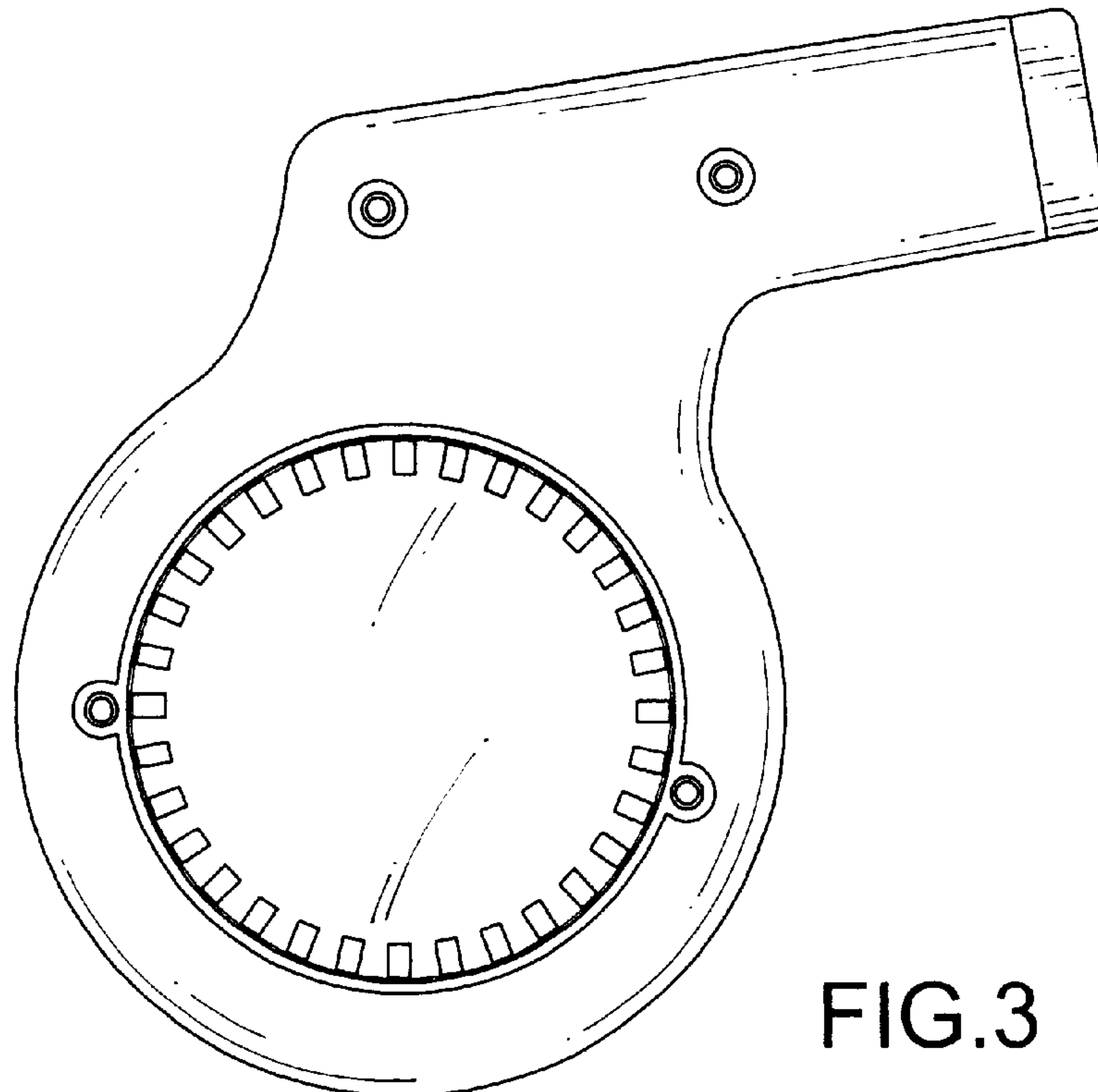

FIG.3

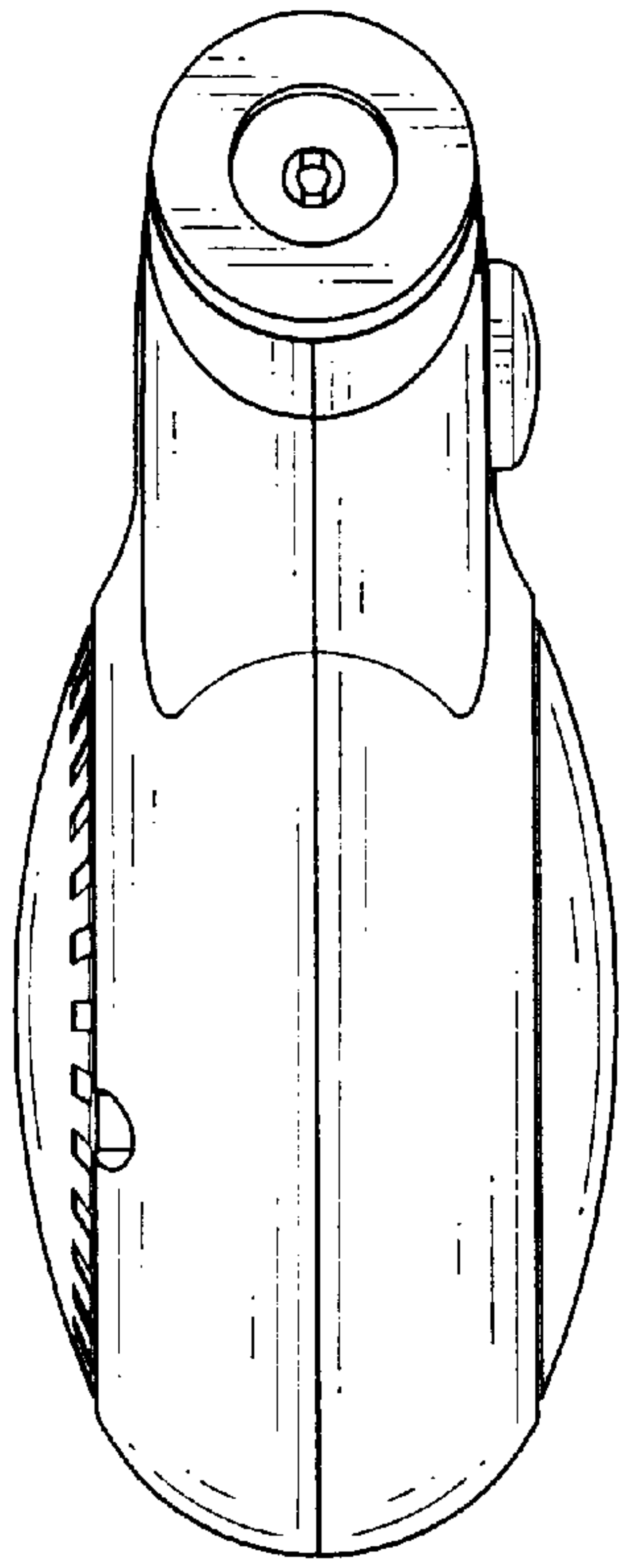

FIG. 4

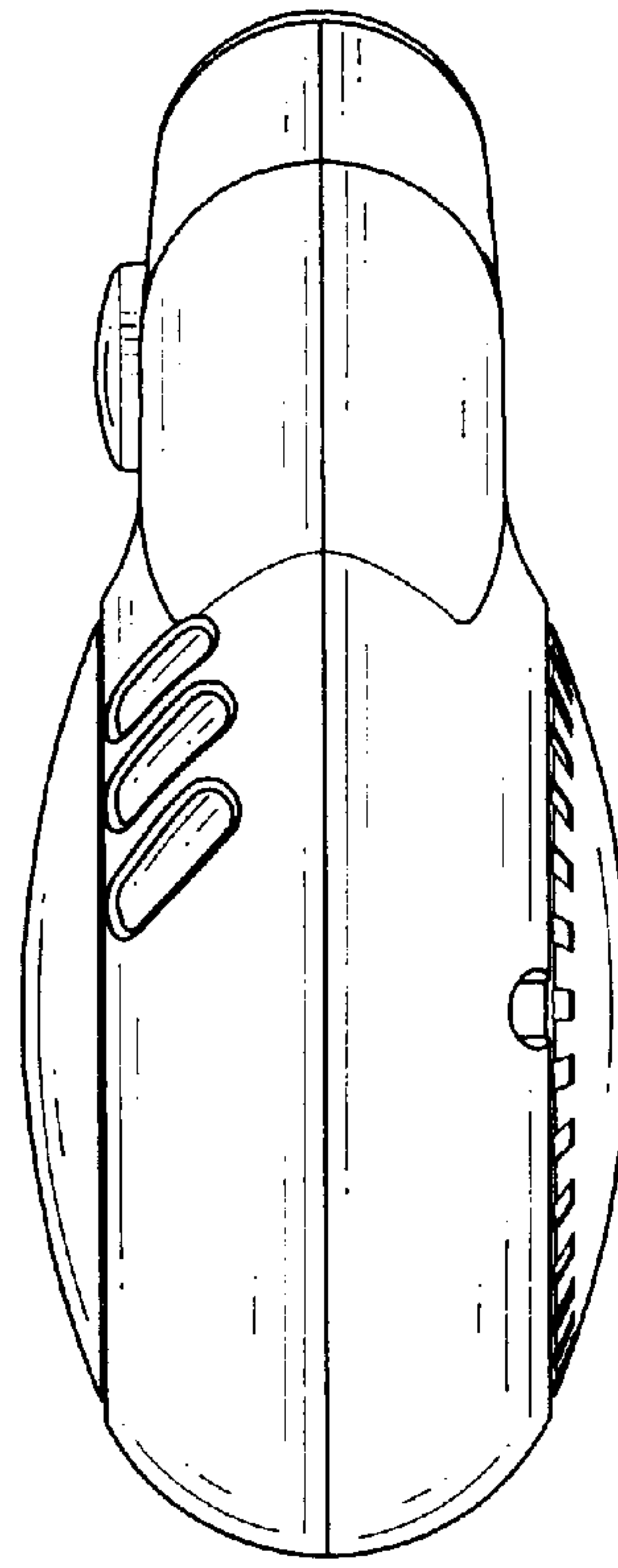

FIG. 5

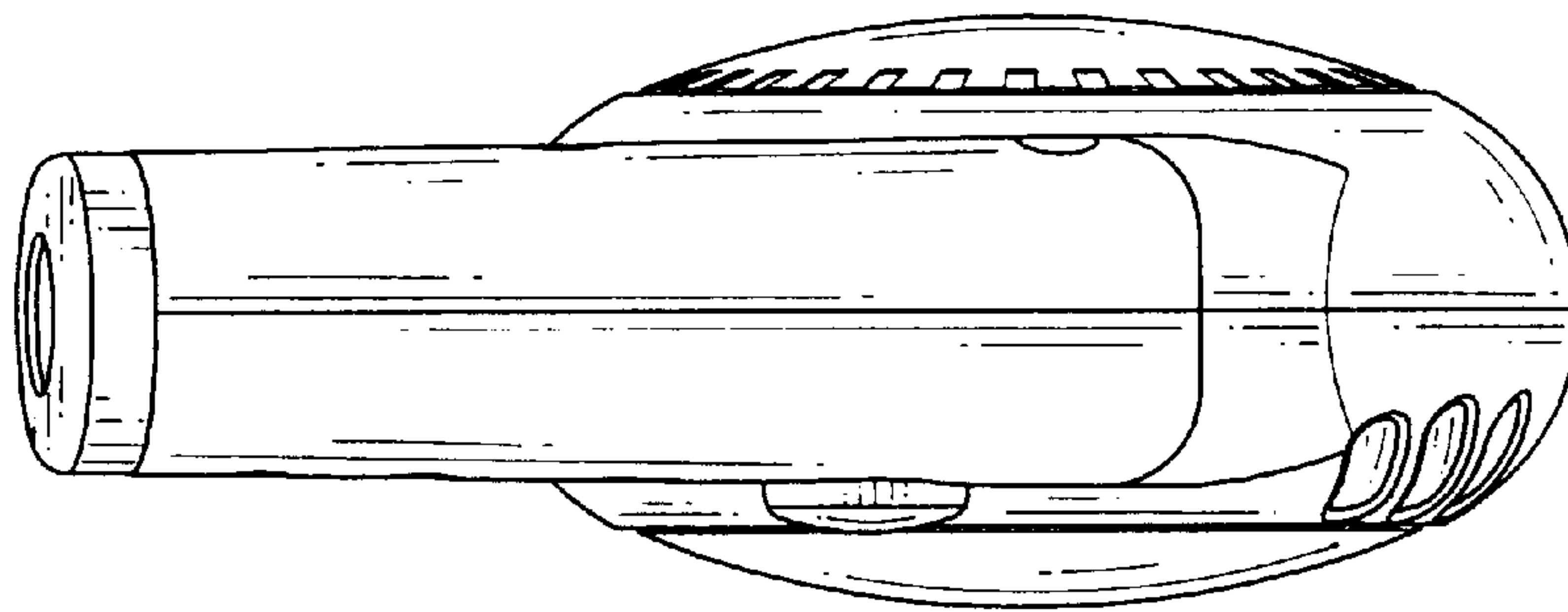

FIG. 6

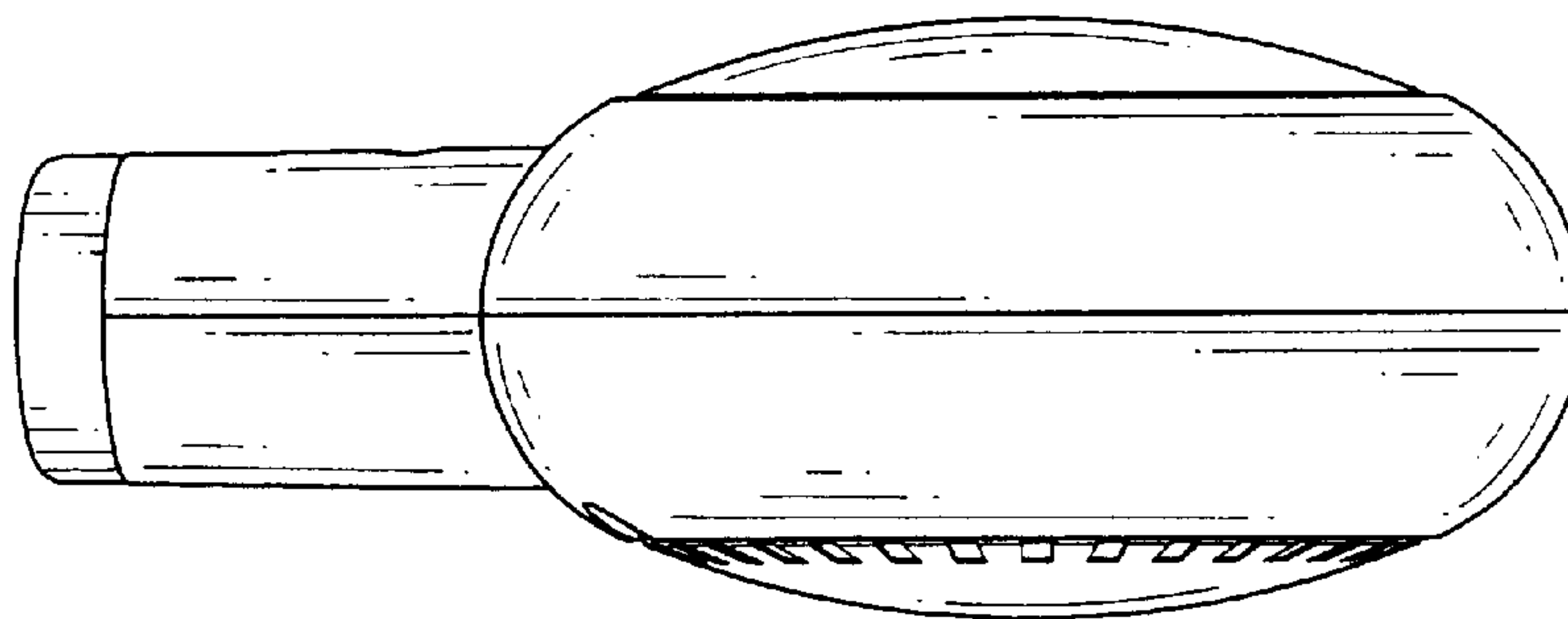

FIG. 7