

US00D504458S

(12) **United States Design Patent**  
**Edwards**

(10) **Patent No.: US D504,458 S**

(45) **Date of Patent: \*\* Apr. 26, 2005**

(54) **INSTRUMENT EFFECTS BOX**

(76) **Inventor: Jon Edwards, 1237 Hollywood Way,  
Apt. C, Burbank, CA (US) 91505**

(\*\*) **Term: 14 Years**

(21) **Appl. No.: 29/172,820**

(22) **Filed: Dec. 17, 2002**

(51) **LOC (7) Cl. .... 17-03**

(52) **U.S. Cl. .... D17/20; D17/99**

(58) **Field of Search .... 84/600, 626, 662,  
84/671, 701, 737, 422.1, 267, 746, 721;  
D17/14-15, 17-21, 99; D1/111, 106; D32/43;  
D13/167**

D400,560 S	11/1998	Ridinger	
D401,963 S	12/1998	Schneider	
D405,461 S	2/1999	Excellente	
5,981,862 A *	11/1999	Geier, Jr. ....	84/746
D422,661 S	4/2000	Edwards et al.	
D422,662 S	4/2000	Edwards et al.	
6,242,682 B1 *	6/2001	Marinic et al. ....	84/626
D459,381 S	6/2002	Ridinger	

\* cited by examiner

*Primary Examiner*—Ruth McInroy

(74) *Attorney, Agent, or Firm*—Karl Stauss

(57) **CLAIM**

The ornamental design for an instrument effects box, as shown and described.

**DESCRIPTION**

FIG. 1 is a perspective view of an instrument effects box showing my new design;  
FIG. 2 is a top plan view thereof;  
FIG. 3 is a right side elevational view thereof, the left side elevational view being a mirror image;  
FIG. 4 is a rear elevational view thereof; and,  
FIG. 5 is a front elevational view thereof.  
The bottom plan view is unornamental and forms no part of the claimed design.

**1 Claim, 3 Drawing Sheets**

(56) **References Cited**

**U.S. PATENT DOCUMENTS**

4,006,441 A *	2/1977	Goodrich .....	338/153
D244,214 S *	5/1977	Ross et al. ....	D14/217
D244,215 S *	5/1977	Ross .....	D14/217
D246,649 S *	12/1977	Braaten .....	D13/167
D260,524 S *	9/1981	Satoh .....	D13/167
D275,111 S *	8/1984	Chapman .....	D17/20
D345,756 S	4/1994	Clothier	
5,535,642 A *	7/1996	Moll .....	74/561
D388,601 S	1/1998	Edwards	
D400,234 S *	10/1998	Ridinger .....	D17/20

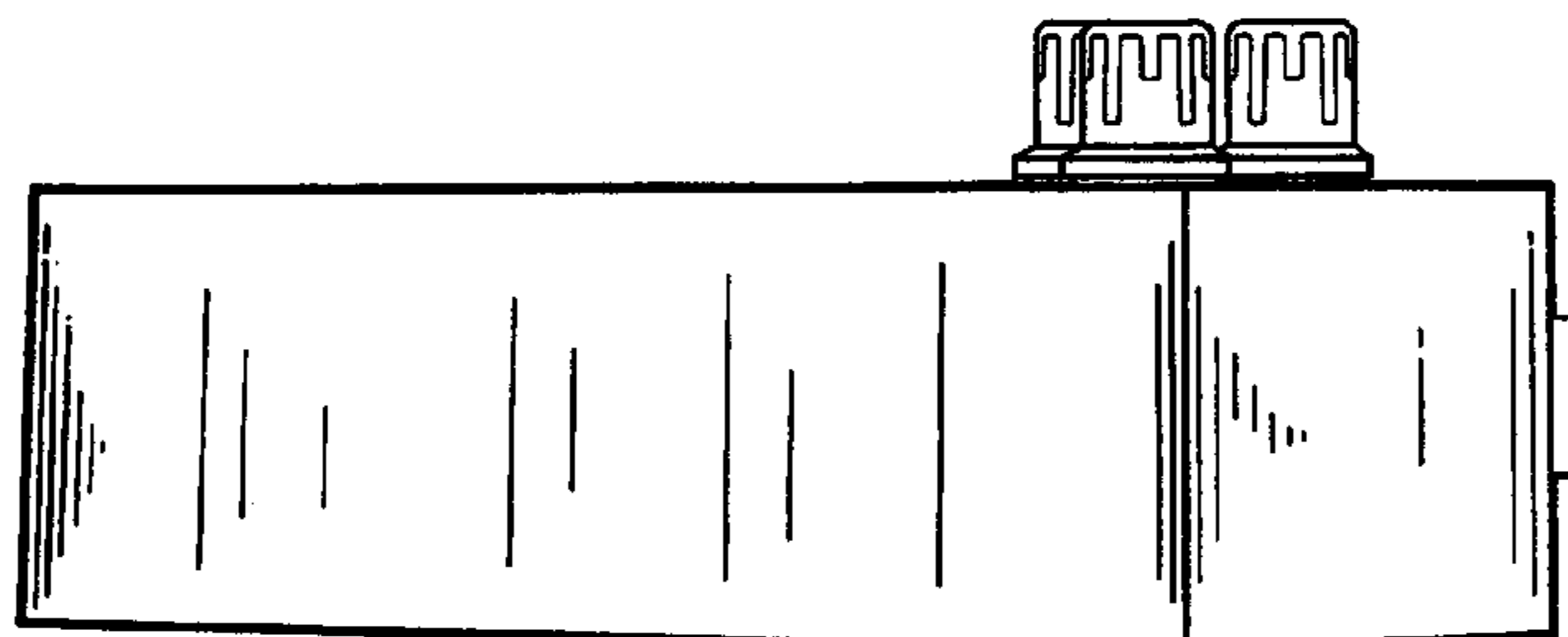
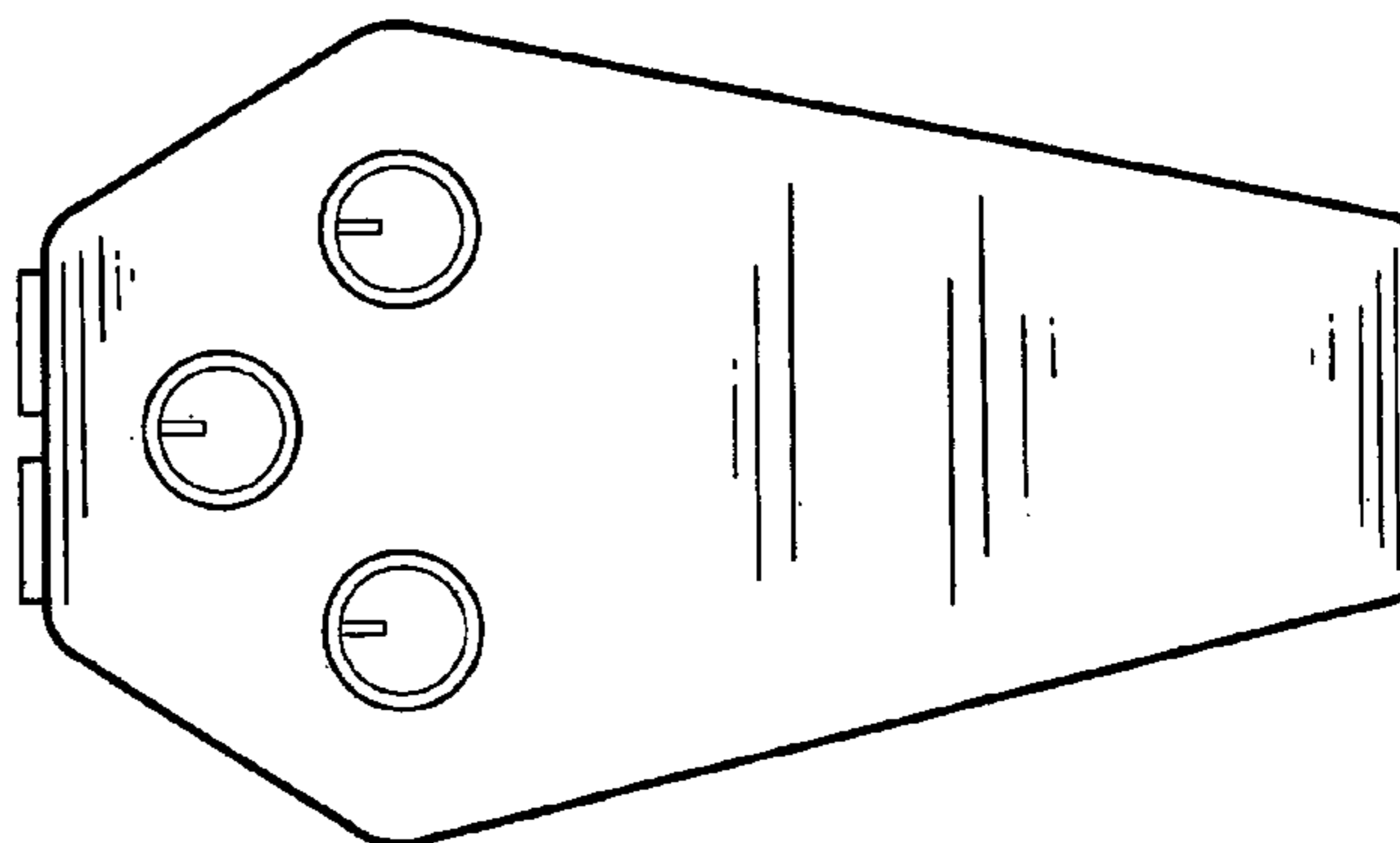
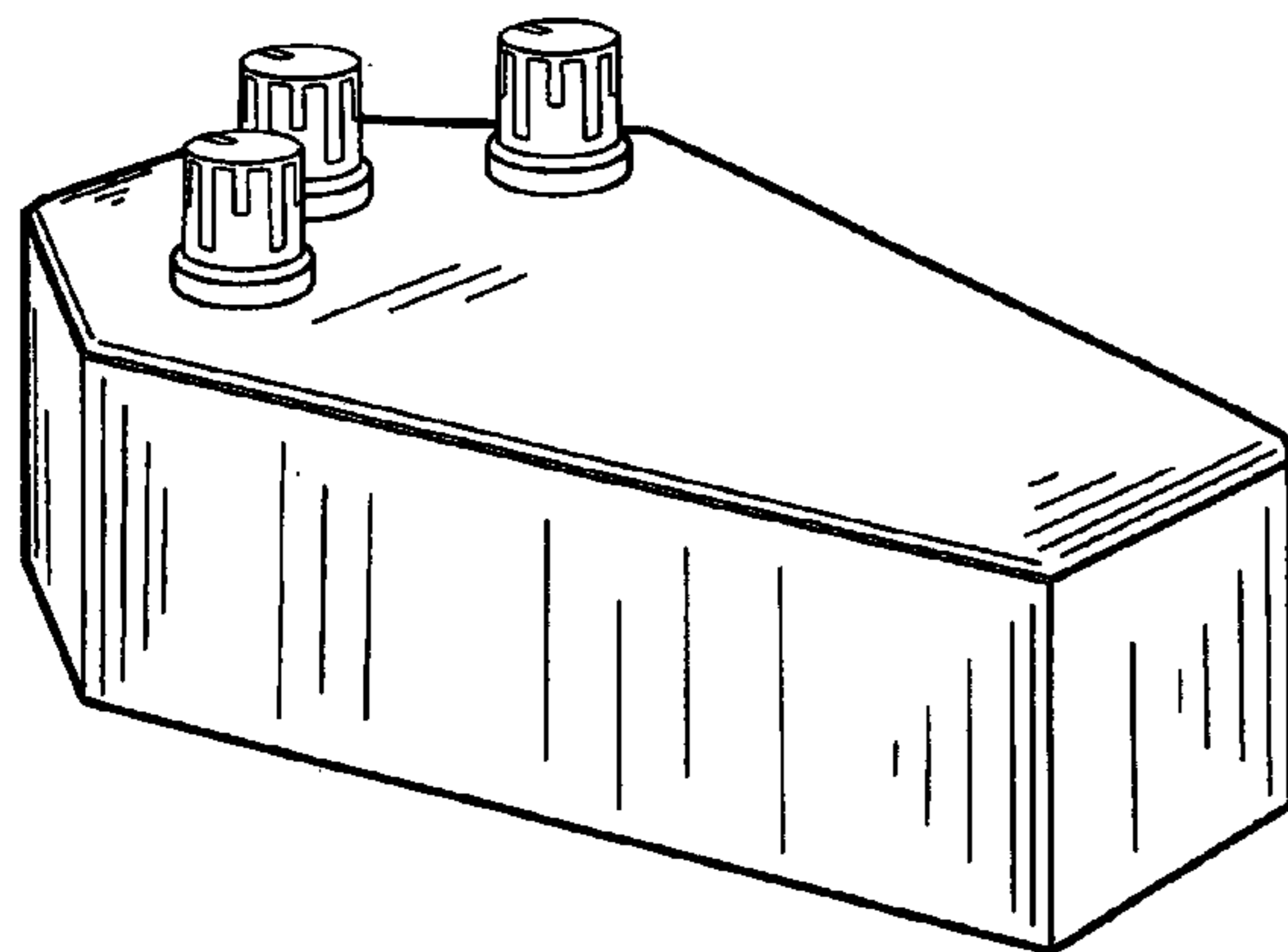

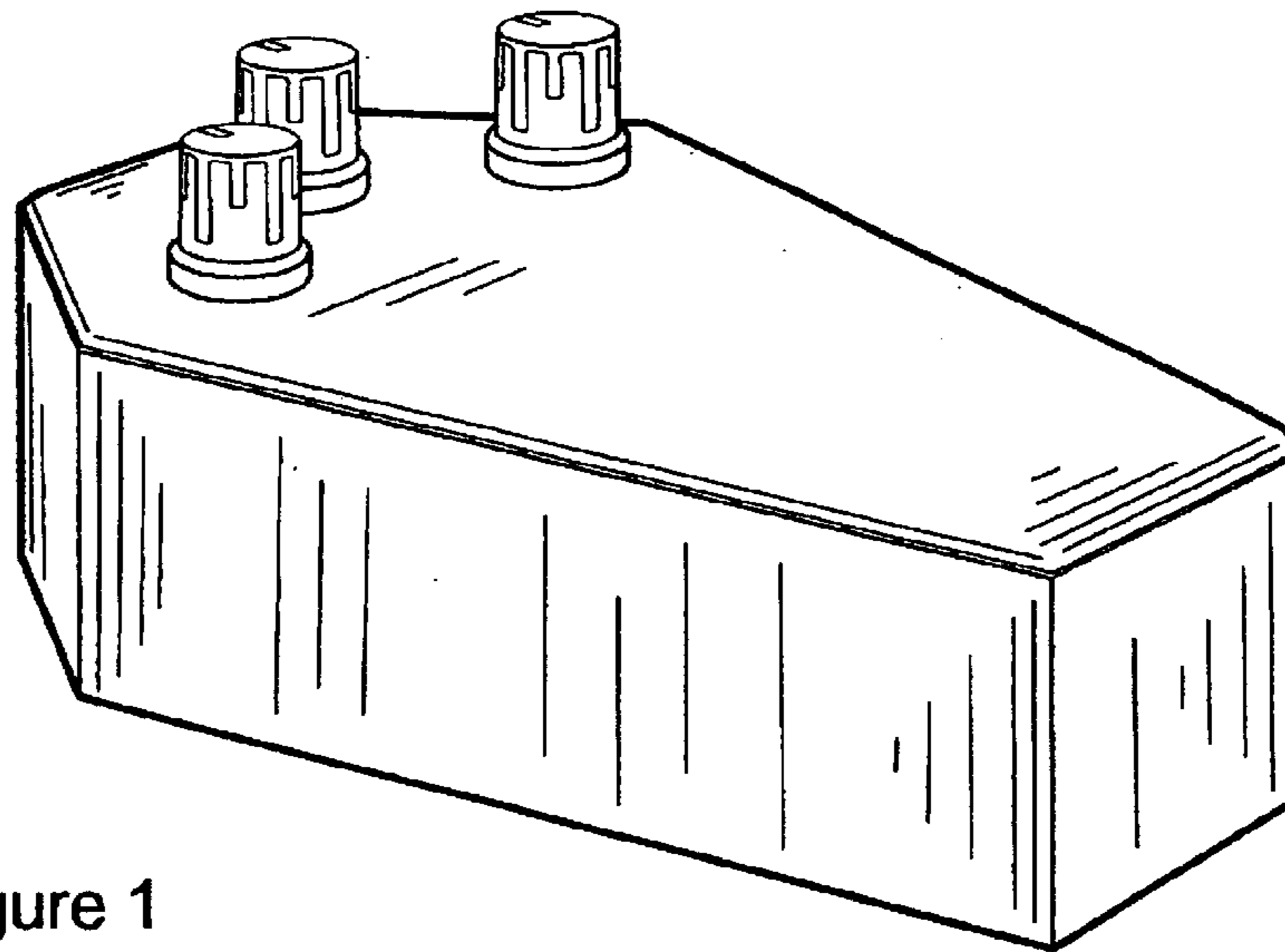

Figure 1

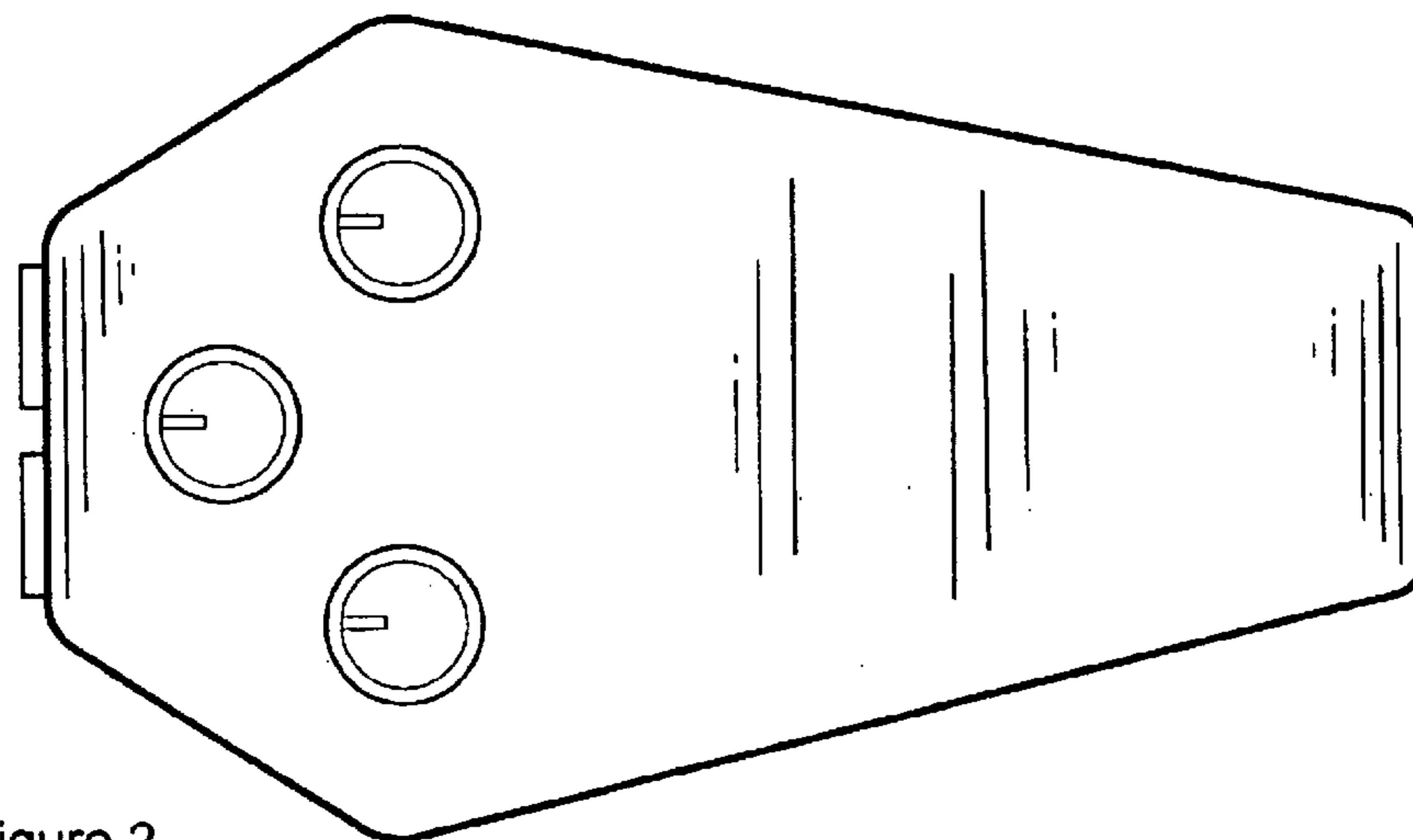

Figure 2

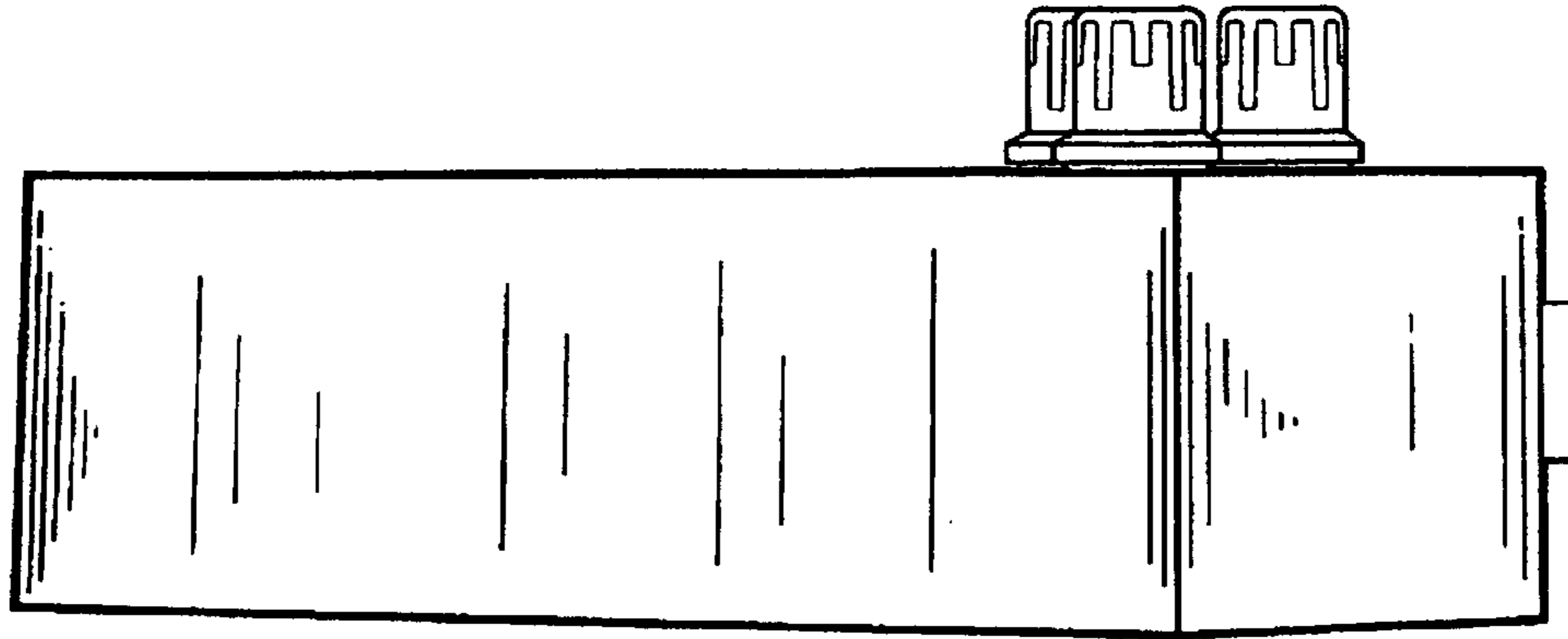

Figure 3

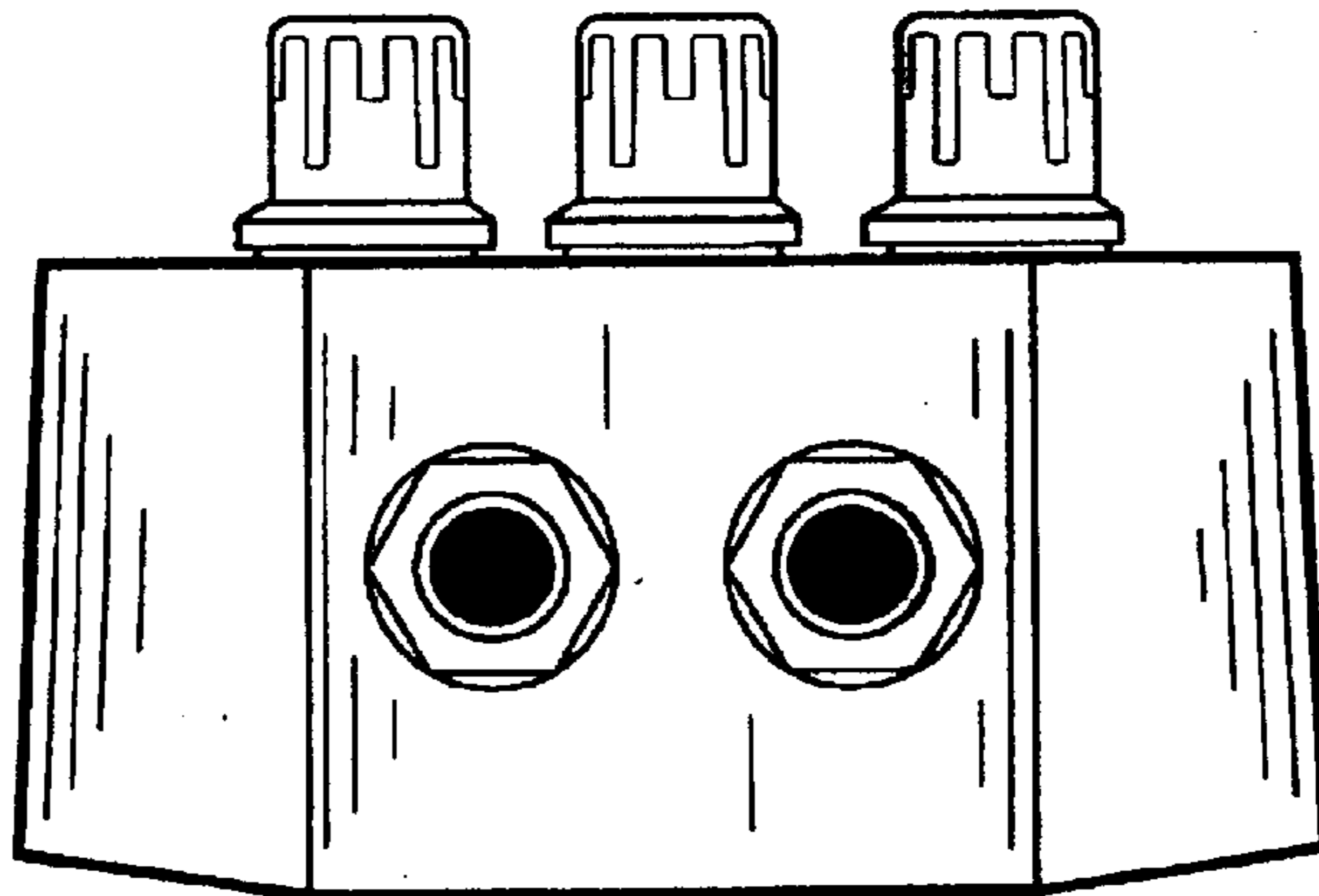

Figure 4

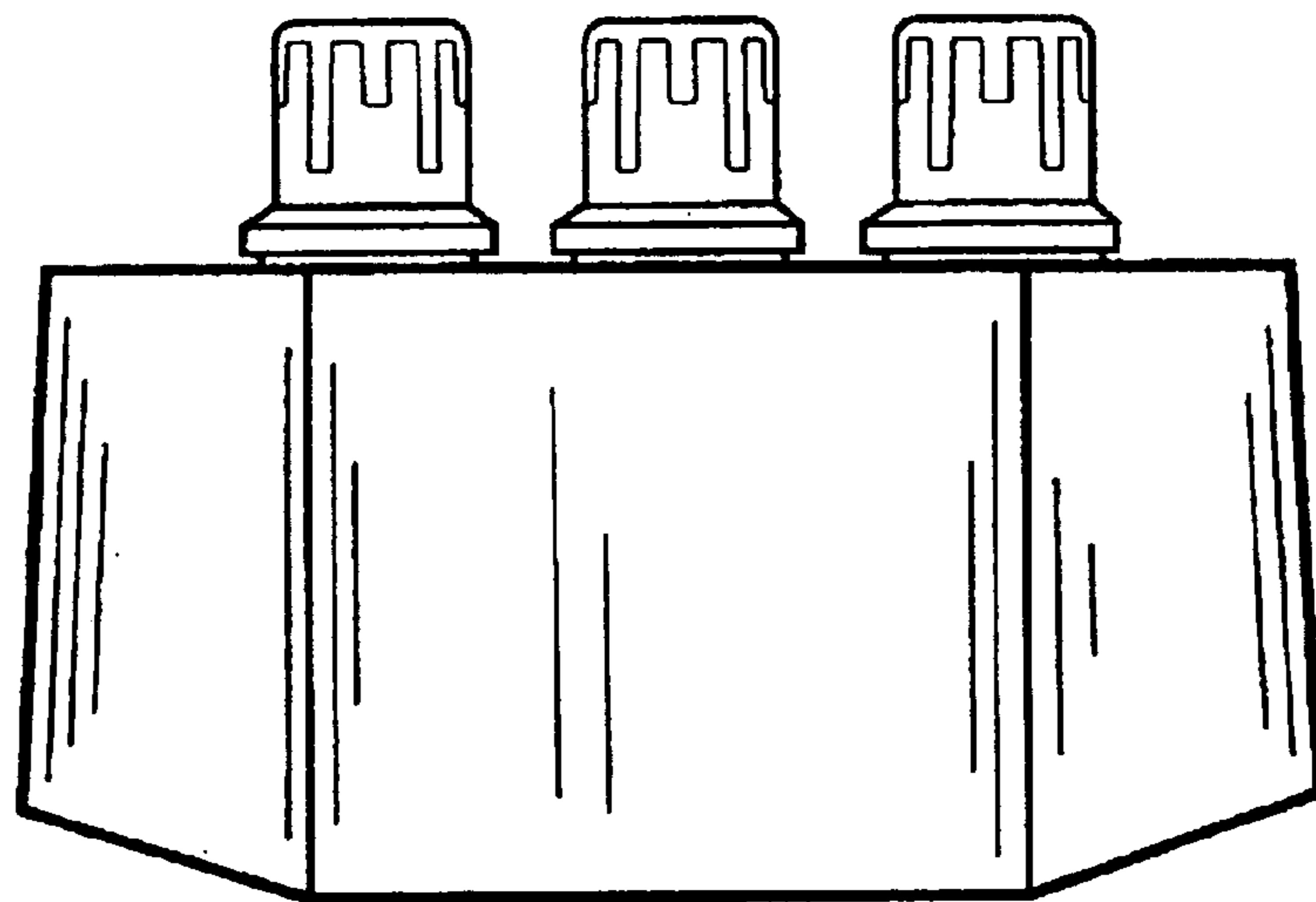

Figure 5