

US00D504358S

(12) **United States Design Patent**  
**Miller, Jr. et al.**

(10) **Patent No.:** **US D504,358 S**

(45) **Date of Patent:** **\*\* Apr. 26, 2005**

(54) **MOTORCYCLE FRAME**

D480,335 S 10/2003 James

(76) Inventors: **Richard C. Miller, Jr.**, 43 Washington Pl., Morristown, NJ (US) 07960; **Glenn R. Bratcher, Jr.**, 54 Schmitz Ter., Mount Arlington, NJ (US) 07856

*Primary Examiner*—Alan P. Douglas  
*Assistant Examiner*—Linda Brooks  
(74) *Attorney, Agent, or Firm*—Richard C. Litman

(\*\*) Term: **14 Years**

(57) **CLAIM**

The ornamental design for a motorcycle frame, as shown and described.

(21) Appl. No.: **29/203,101**

**DESCRIPTION**

(22) Filed: **Apr. 9, 2004**

(51) **LOC (7) Cl.** ..... **12-11**

(52) **U.S. Cl.** ..... **D12/110**

(58) **Field of Search** ..... D12/110; 180/219, 180/311, 312; 280/281.1, 288.1–288.3

FIG. 1 is an environmental perspective view of a motorcycle frame showing our new design;  
FIG. 2 is a front elevational view thereof;  
FIG. 3 is a rear elevational view thereof;  
FIG. 4 is a right side elevational view with the left side being a mirror image thereof;  
FIG. 5 is a top view thereof; and,  
FIG. 6 is a bottom view thereof.

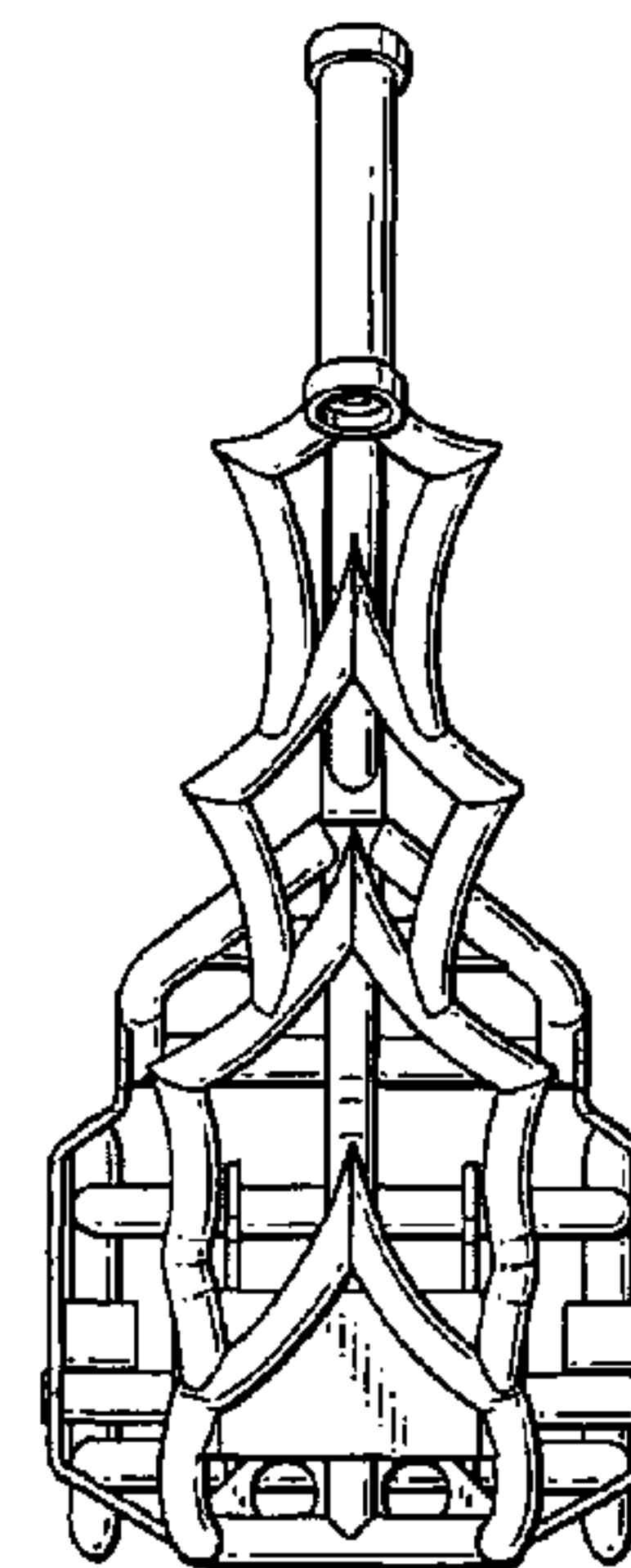
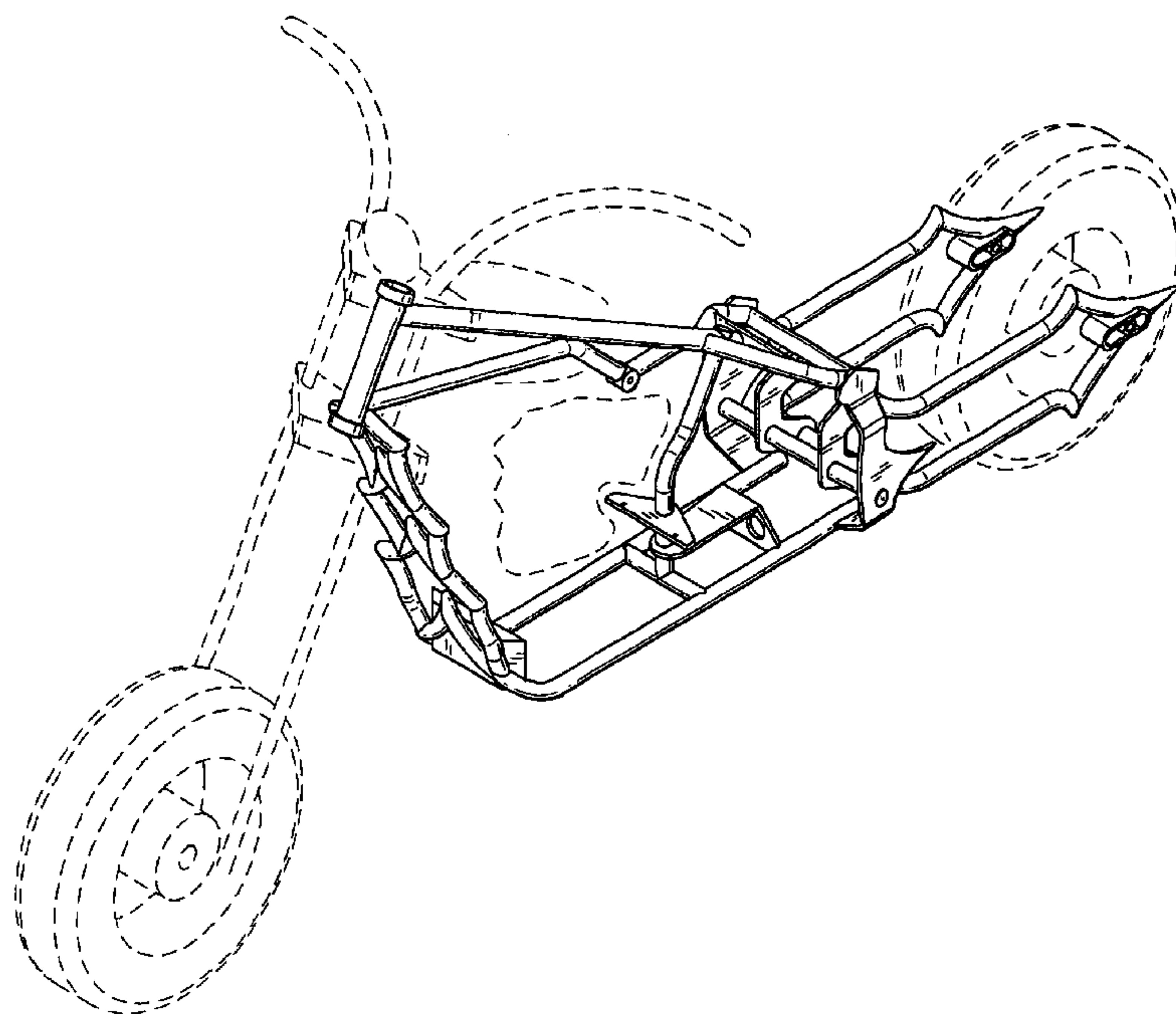
The broken line showing of portions of a motorcycle is for illustrative purposes only and forms no part of the claimed design.

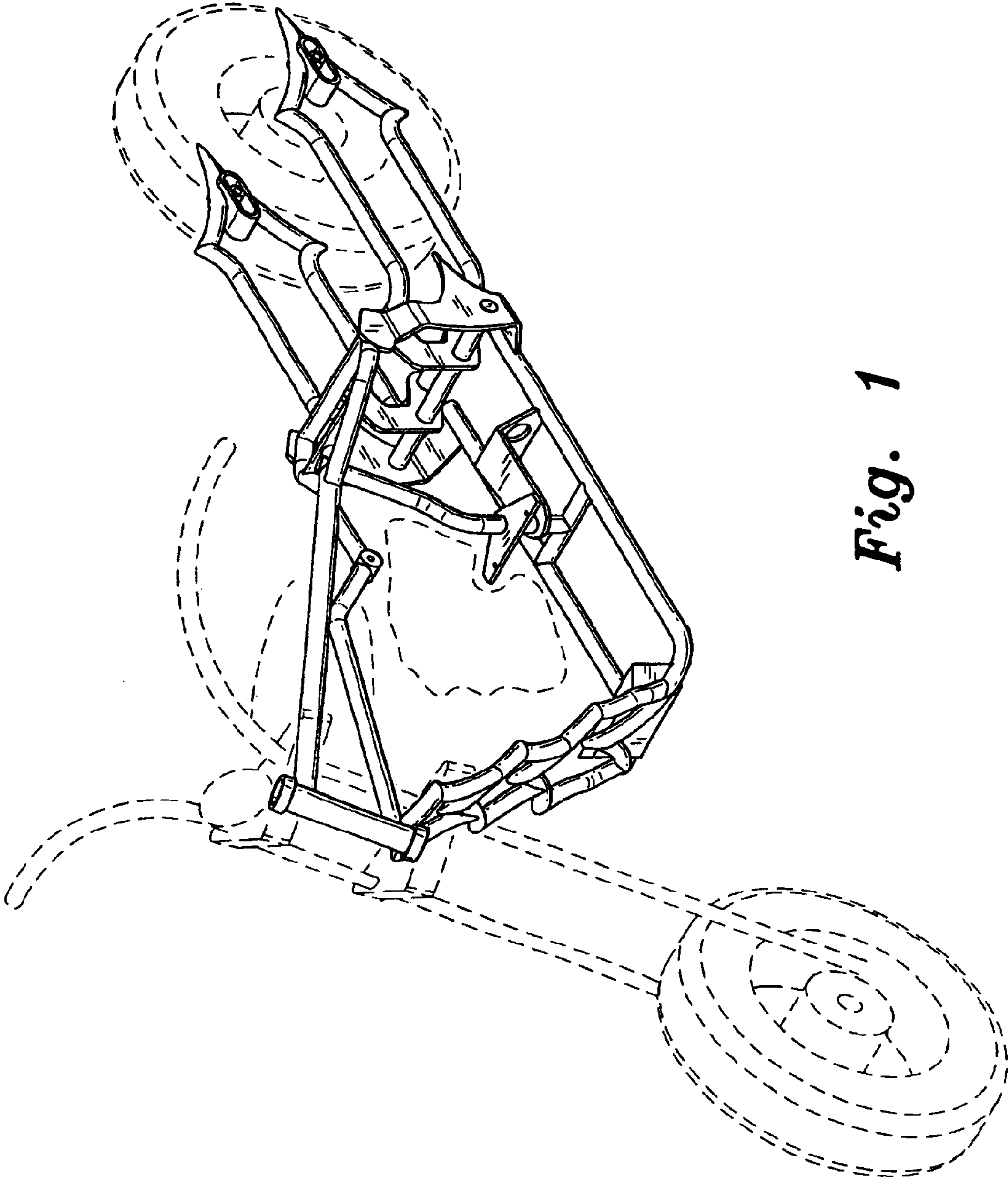
(56) **References Cited**

**U.S. PATENT DOCUMENTS**

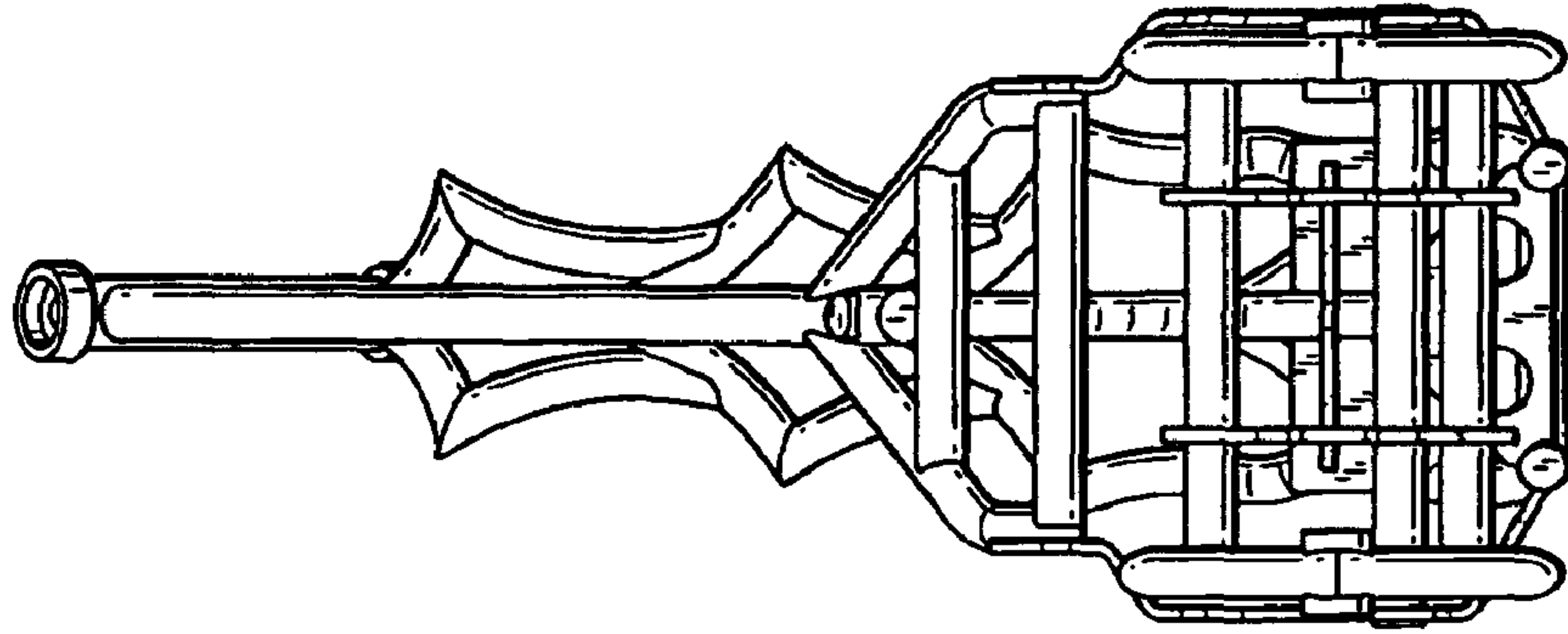
D275,470 S	9/1984	Koizumi
D378,996 S	4/1997	Ysker
D425,453 S	5/2000	Manescalchi
6,142,498 A	11/2000	Smith

**1 Claim, 4 Drawing Sheets**

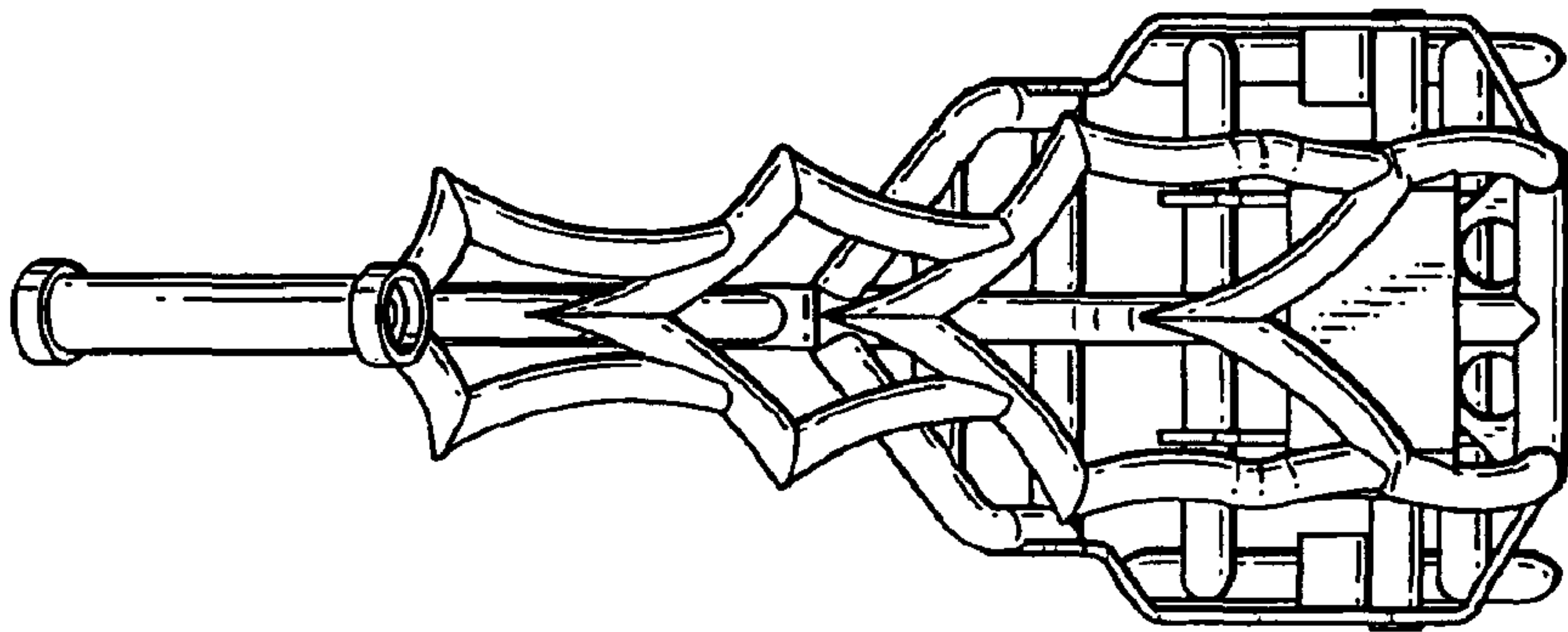




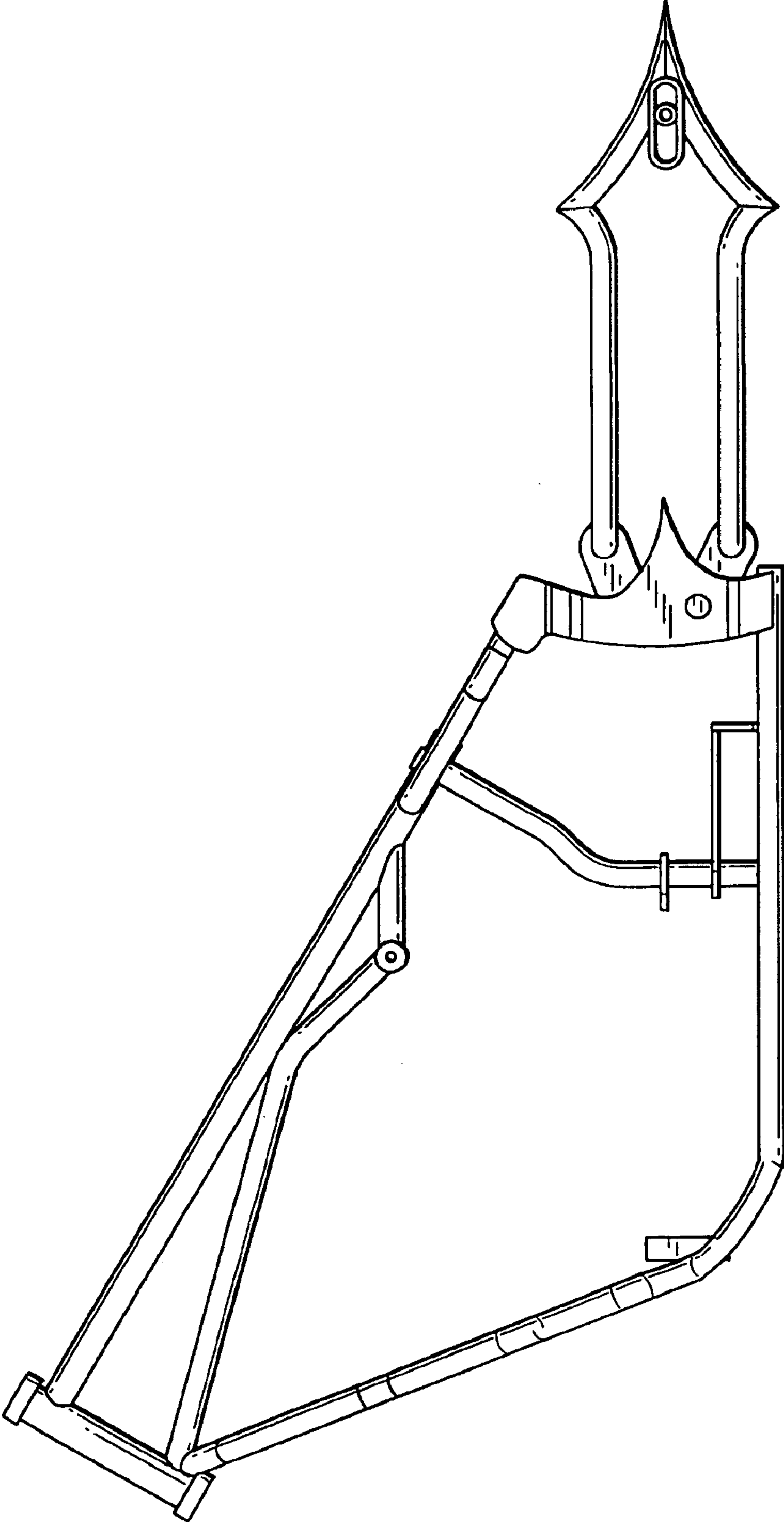
*Fig. 1*



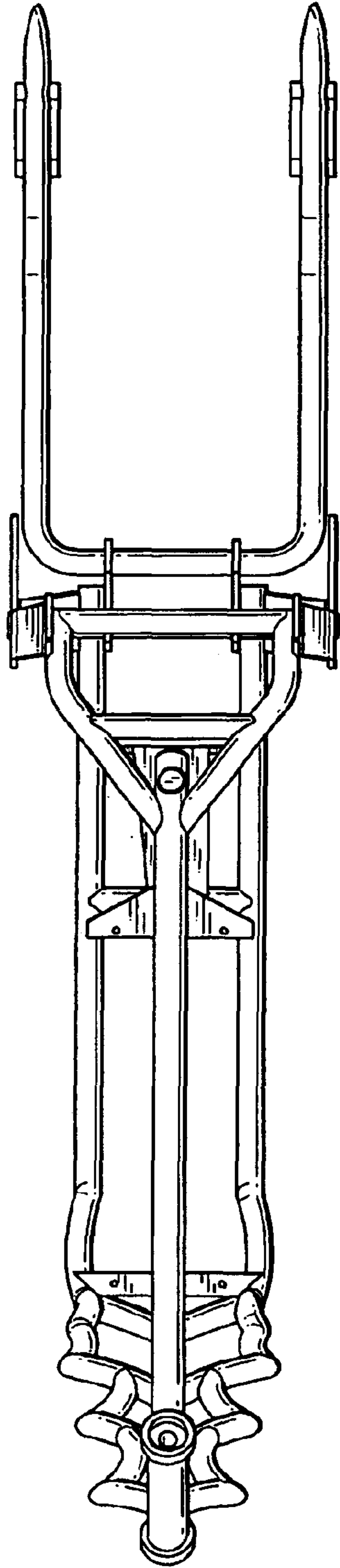
*Fig. 3*



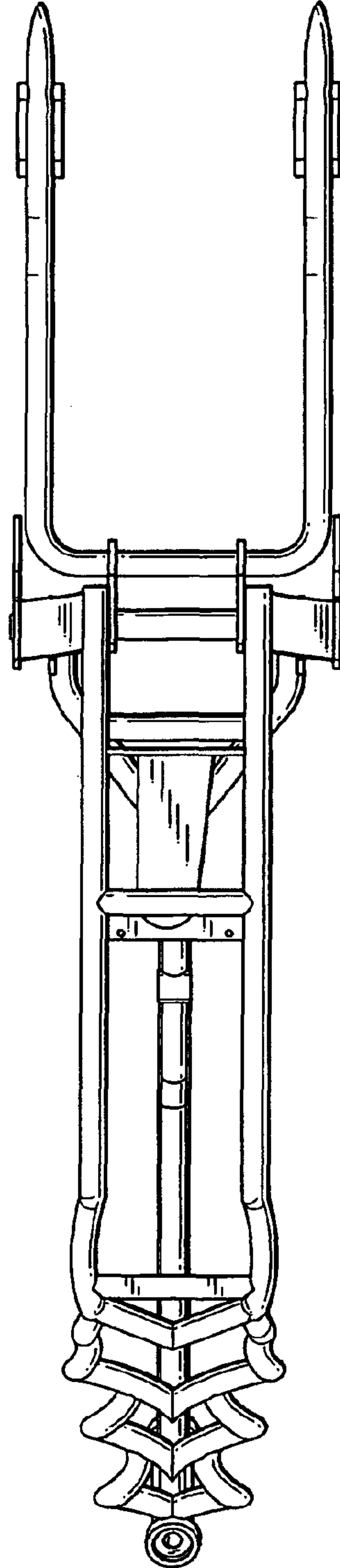
*Fig. 2*



*Fig. 4*



*Fig. 5*



*Fig. 6*