

US00D504243S

(12) **United States Design Patent** (10) **Patent No.:** **US D504,243 S**  
**Begin et al.** (45) **Date of Patent:** **\*\* Apr. 26, 2005**

(54) **BOAT CHAIR**

(75) Inventors: **Jason Begin**, Rockford, MI (US);  
**Anthony L. Slabaugh**, Belmont, MI (US)

(73) Assignee: **Attwood Corporation**, Lowell, MI (US)

(\*\*) Term: **14 Years**

(21) Appl. No.: **29/200,030**

(22) Filed: **Feb. 23, 2004**

(51) **LOC (7) Cl.** ..... **06-01**

(52) **U.S. Cl.** ..... **D6/356**

(58) **Field of Search** ..... D6/334-336, 356,  
D6/366, 367, 368, 374, 376, 380, 500-502;  
297/378.1, 378.12, 378.14, 452.18, 452.21,  
452.29, 452.38, DIG. 2; 114/363

(56) **References Cited**

**U.S. PATENT DOCUMENTS**

3,245,717 A	4/1966	Levy	
4,746,166 A	5/1988	Sadan	
4,775,187 A	10/1988	Herr	
D303,878 S	* 10/1989	Goldsmith	..... D6/368
5,018,788 A	5/1991	Cedergreen	
5,052,076 A	10/1991	Spaeth	
5,209,178 A	* 5/1993	Rowe	..... 114/363
5,658,047 A	8/1997	Ratza et al.	
5,785,383 A	7/1998	Otero	
D398,172 S	9/1998	Greaves et al.	
5,820,221 A	10/1998	Greaves et al.	

D407,570 S	4/1999	Frauenberger	
D411,381 S	6/1999	Greaves et al.	
D414,349 S	* 9/1999	Jenkins et al.	..... D6/366
D420,816 S	2/2000	Wilcox et al.	
6,089,669 A	7/2000	Wilcox et al.	
6,164,724 A	12/2000	Greaves	
D442,400 S	* 5/2001	Simons et al.	..... D6/500
D442,790 S	* 5/2001	Simons et al.	..... D6/366
D449,458 S	10/2001	Malmanger et al.	
D473,390 S	4/2003	Hannon et al.	

\* cited by examiner

*Primary Examiner*—Mimosa De

(74) *Attorney, Agent, or Firm*—Price, Heneveld, Cooper, DeWitt & Litton, LLP

(57) **CLAIM**

We claim the ornamental design for the boat chair, as shown and described.

**DESCRIPTION**

FIG. 1 is a perspective view of a boat chair showing our new design;  
 FIG. 2 is a front elevational view thereof;  
 FIG. 3 is a side elevational view thereof, the opposite side being a mirror image;  
 FIG. 4 is a rear elevational view thereof;  
 FIG. 5 is a top plan view thereof; and,  
 FIG. 6 is a bottom plan view thereof.

The dashed line within the figures are for illustrative purposes only and form no part of the claimed invention.  
 The small broken circles shown on the backrest and seat of the drawing are not part of the claimed design.

**1 Claim, 3 Drawing Sheets**

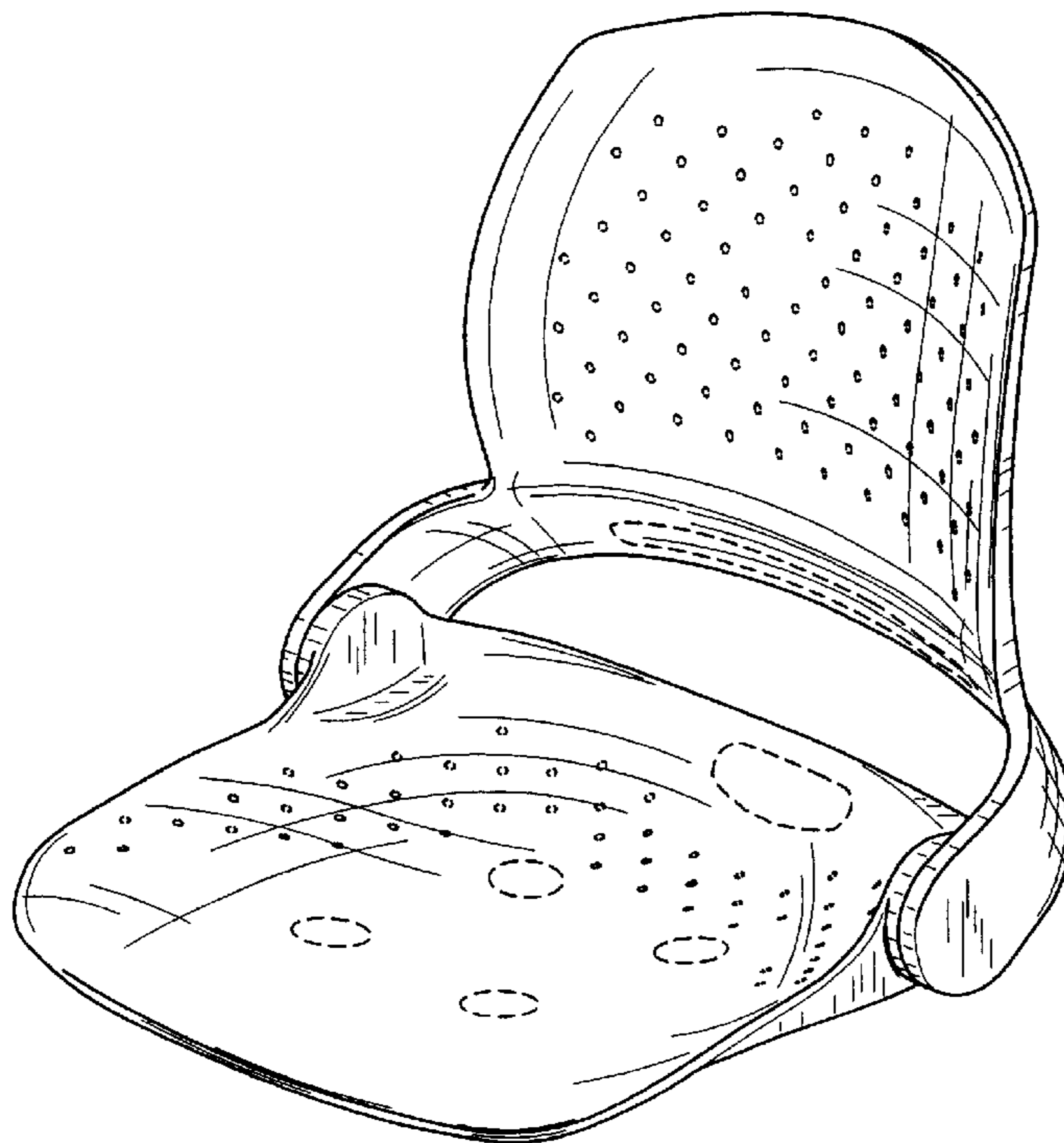

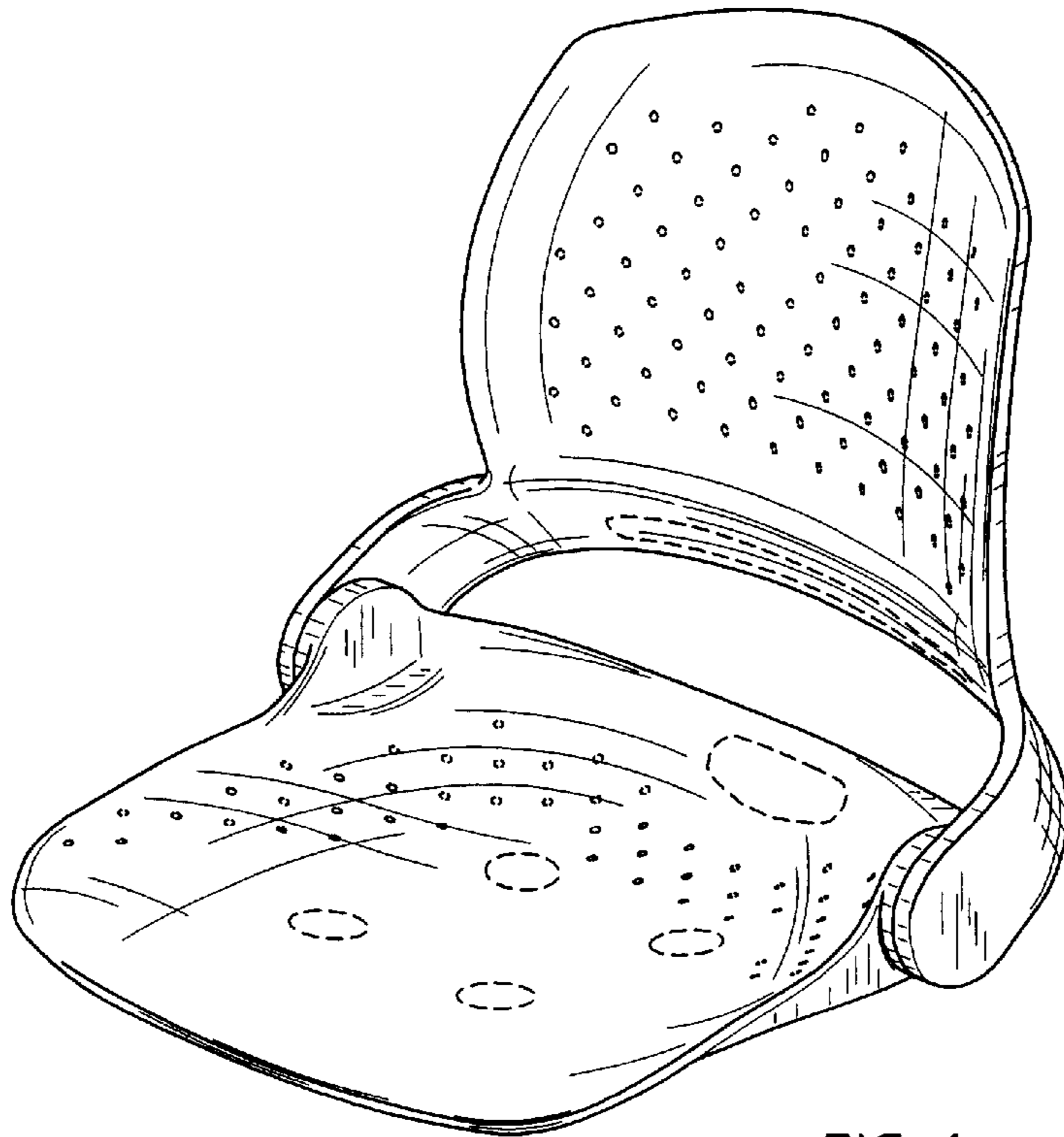

FIG. 1

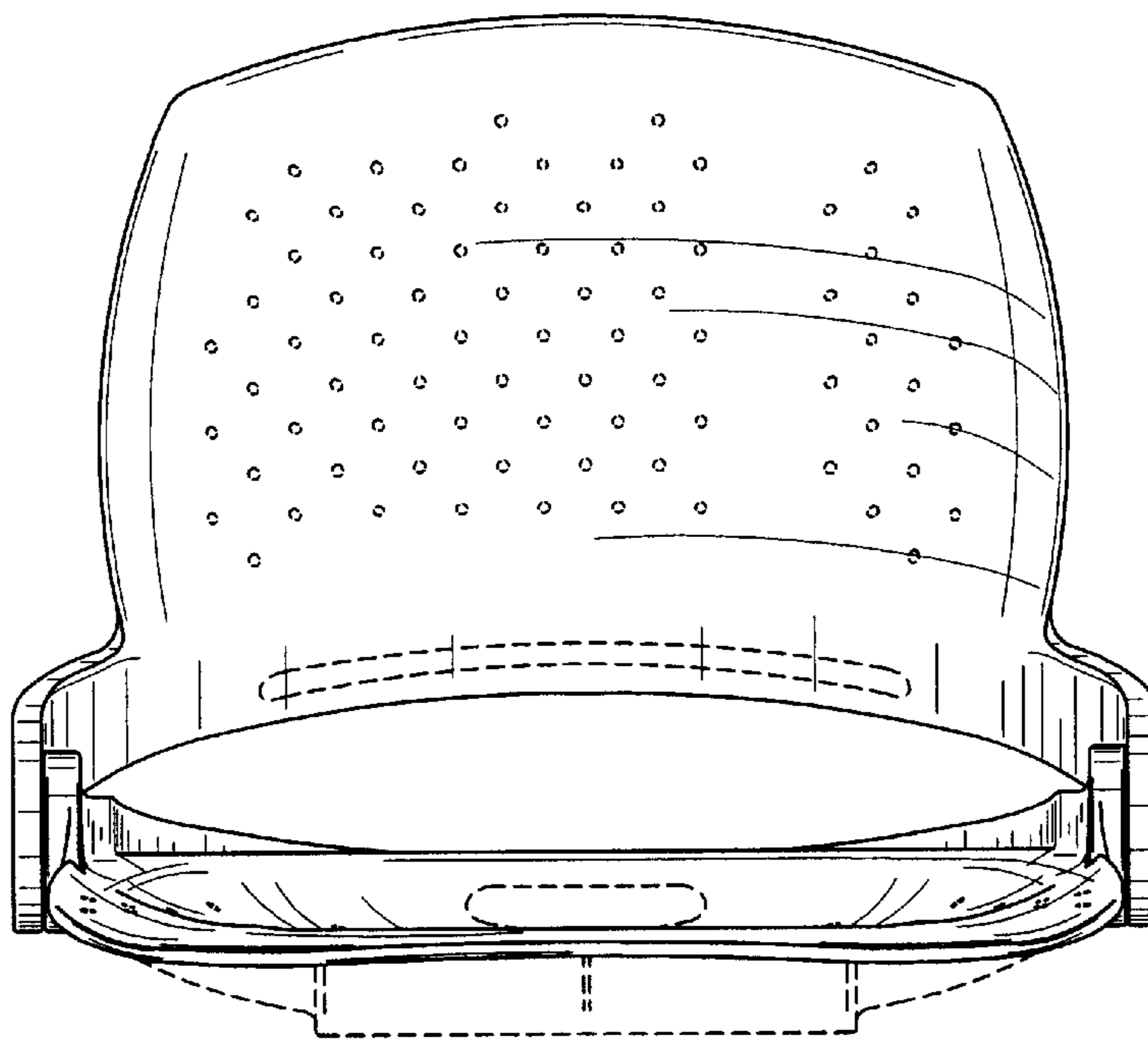

FIG. 2

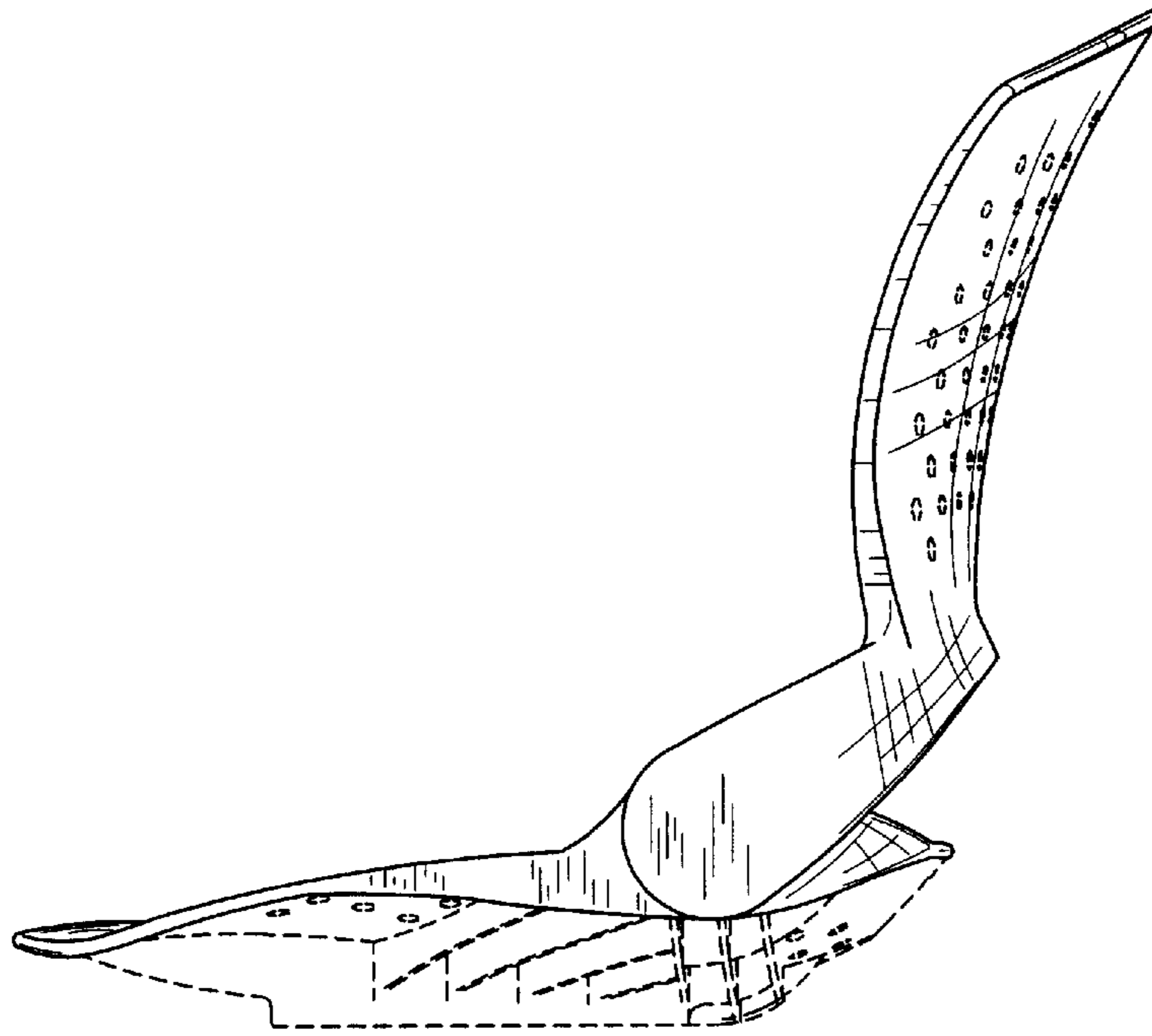

FIG. 3

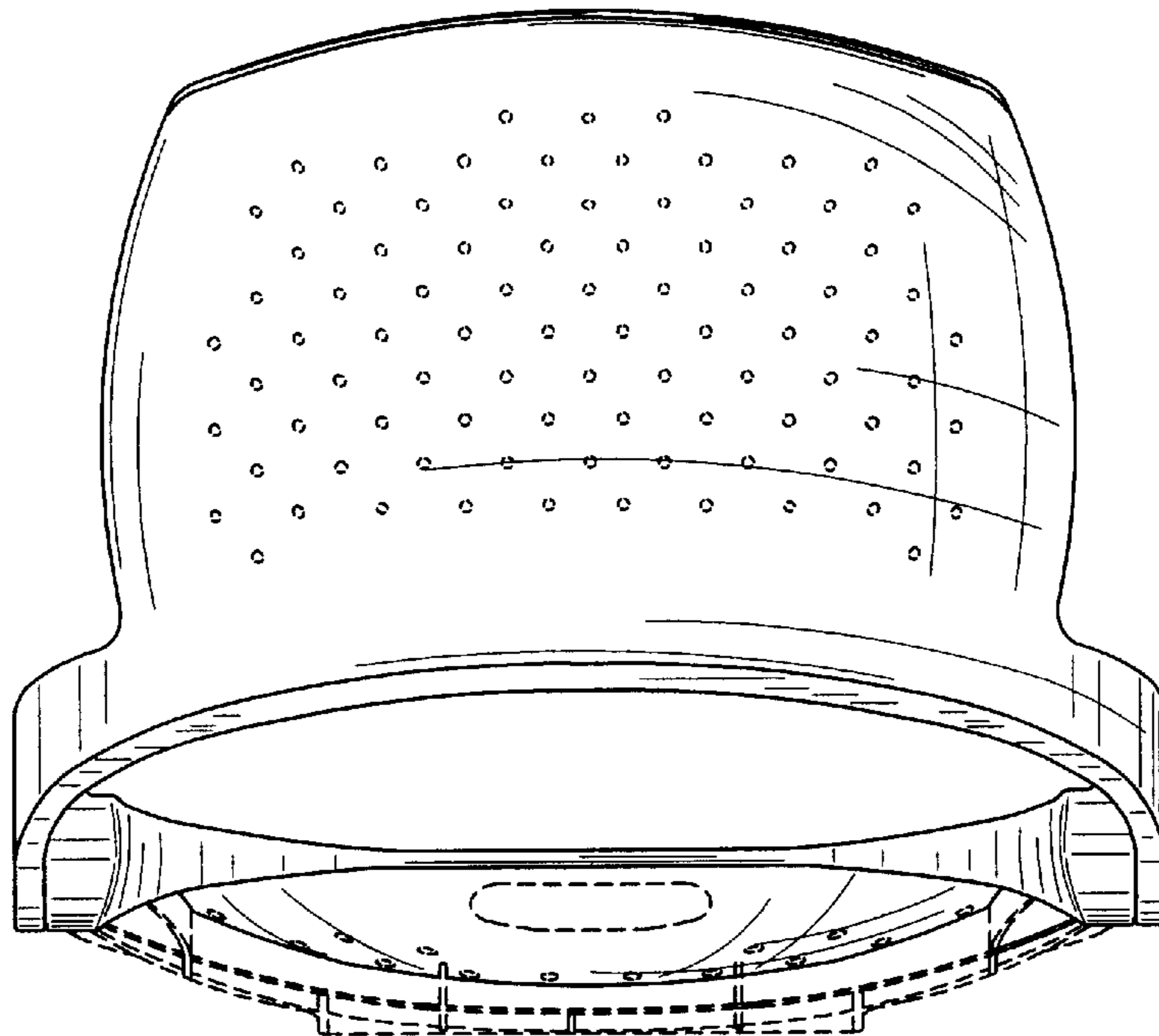

FIG. 4

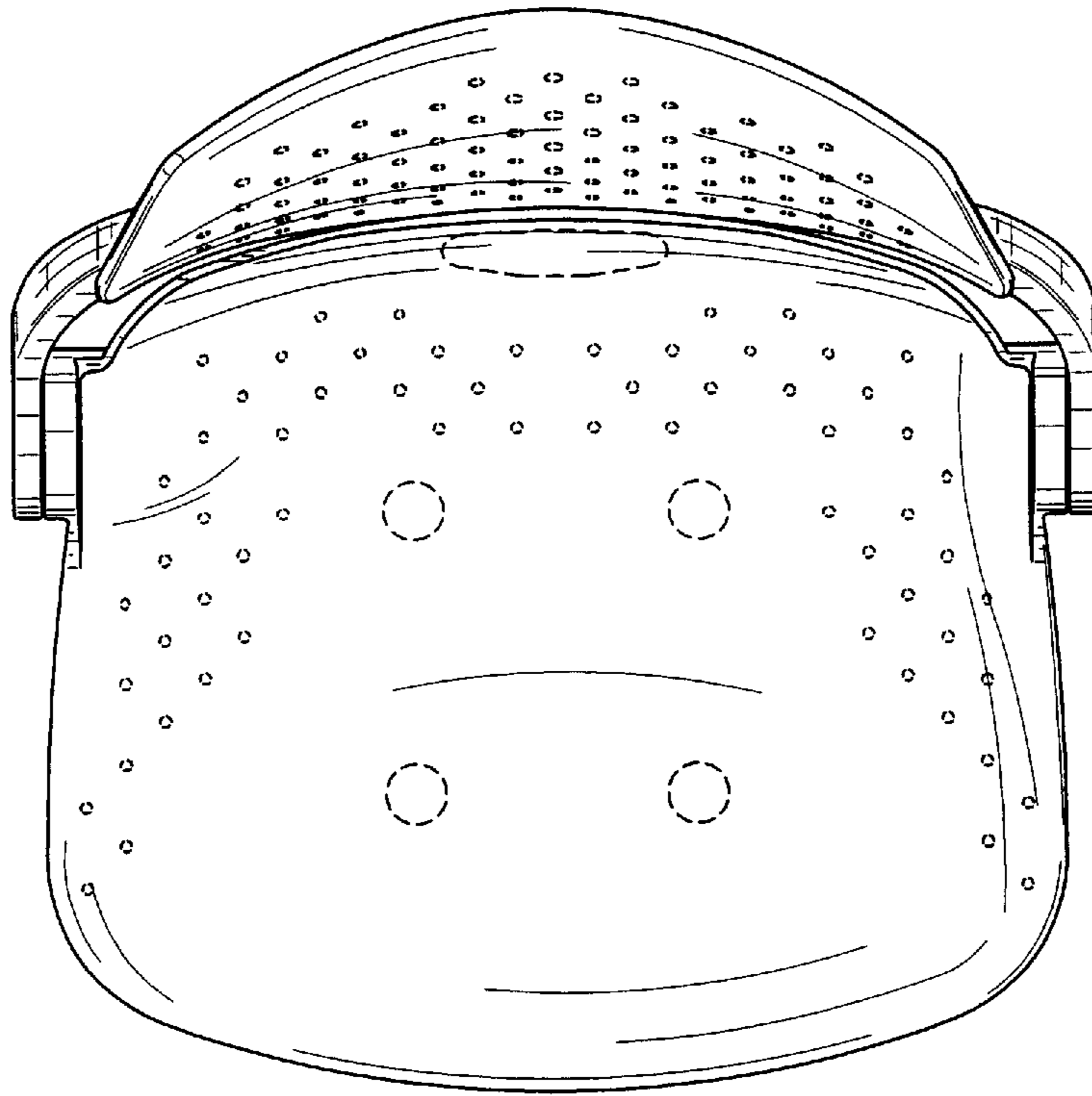

FIG. 5

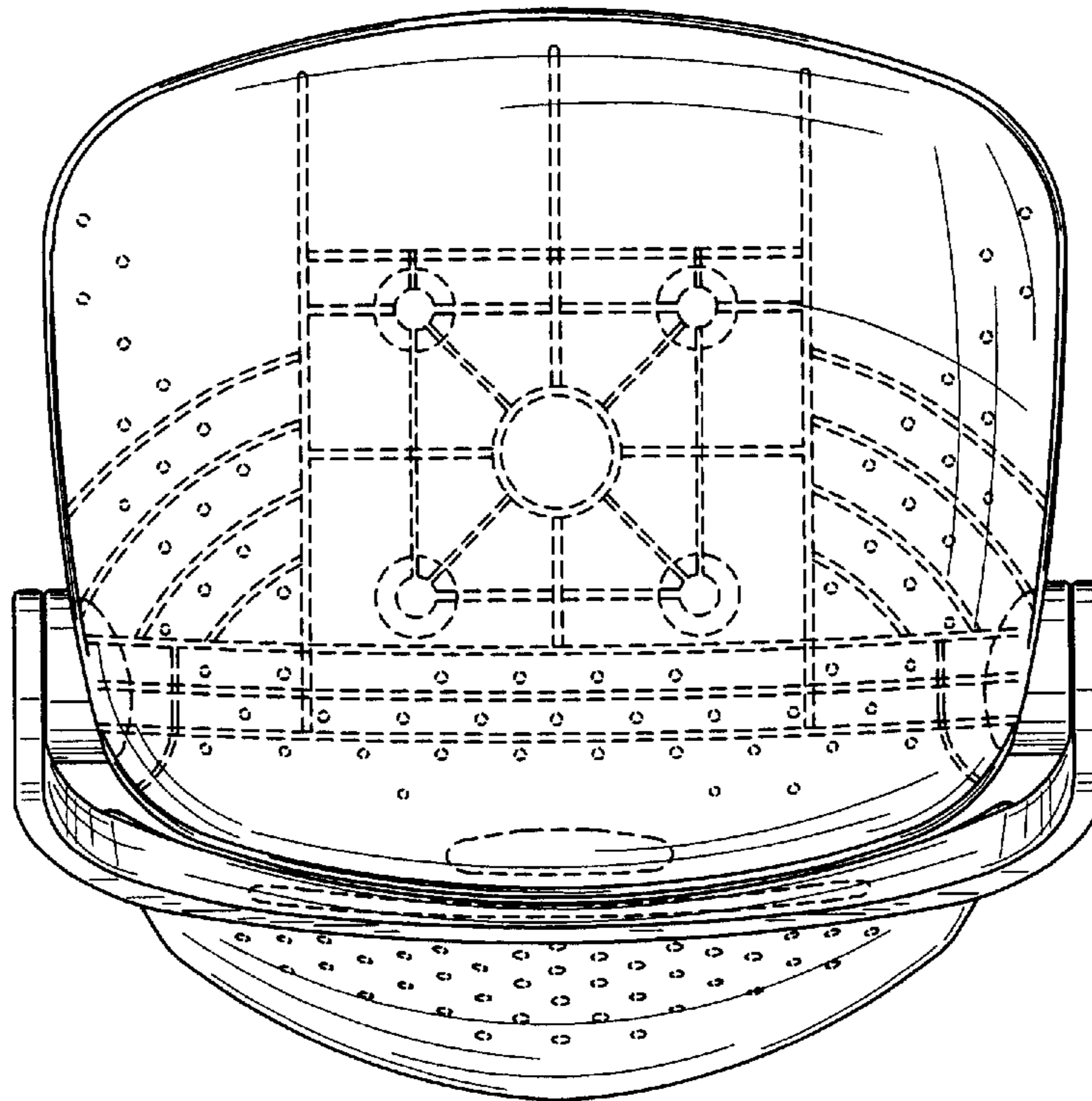

FIG. 6