

US00D503990S

(12) **United States Design Patent** (10) **Patent No.:** **US D503,990 S**
Bacon (45) **Date of Patent:** **** Apr. 12, 2005**

(54) **INTERNALLY LIGHTED CRYSTAL PRISM MIRROR LIGHT FOR VEHICLE**

D373,001 S 8/1996 O'Donnell

* cited by examiner

(76) Inventor: **Jeremy A. Bacon**, P.O. Box 231,
Smyrna, DE (US) 19977

Primary Examiner—Marcus A. Jackson
(74) *Attorney, Agent, or Firm*—Donald R. Schoonover

(**) Term: **14 Years**

(57) **CLAIM**

(21) Appl. No.: **29/206,791**

I claim the ornamental design for an internally lighted crystal prism mirror light for vehicle, as shown and described.

(22) Filed: **Jun. 4, 2004**

(51) **LOC (7) Cl.** **26-06**

(52) **U.S. Cl.** **D26/32**

(58) **Field of Search** D26/28-36; 362/61,
362/80, 80.1, 83, 83.2, 282, 362, 368, 806,
808

DESCRIPTION

FIG. 1 is a perspective view of an internally lighted crystal prism mirror light for vehicle showing my new design; FIG. 2 is a front elevational view thereof; with the exception of a suspension base thereof, the rear elevational view thereof is identical thereto; FIG. 3 is a right side elevational view thereof; with the exception of the suspension base thereof, the elevation view of the other sides are substantially identical thereto; FIG. 4 is a top plan view thereof; FIG. 5 is a bottom plan view thereof; and, FIG. 6 is a perspective view showing the internally lighted crystal prism mirror light for vehicle in use; the broken lines depict environmental structure for illustrative purposes only and form no part of the claimed design.

(56) **References Cited**

U.S. PATENT DOCUMENTS

2,155,822 A	4/1939	Graf	
D181,034 S	9/1957	Bossi	
3,211,903 A	10/1965	McElreath	
3,634,679 A	1/1972	Krzyston	
4,923,721 A	5/1990	Gilmore	
4,996,087 A	2/1991	Rebstock	
D336,263 S	* 6/1993	Basil D26/32
D345,621 S	3/1994	McLaughlin, II	
D347,705 S	* 6/1994	Terry et al. D26/32
5,488,549 A	1/1996	Miller et al.	

1 Claim, 3 Drawing Sheets

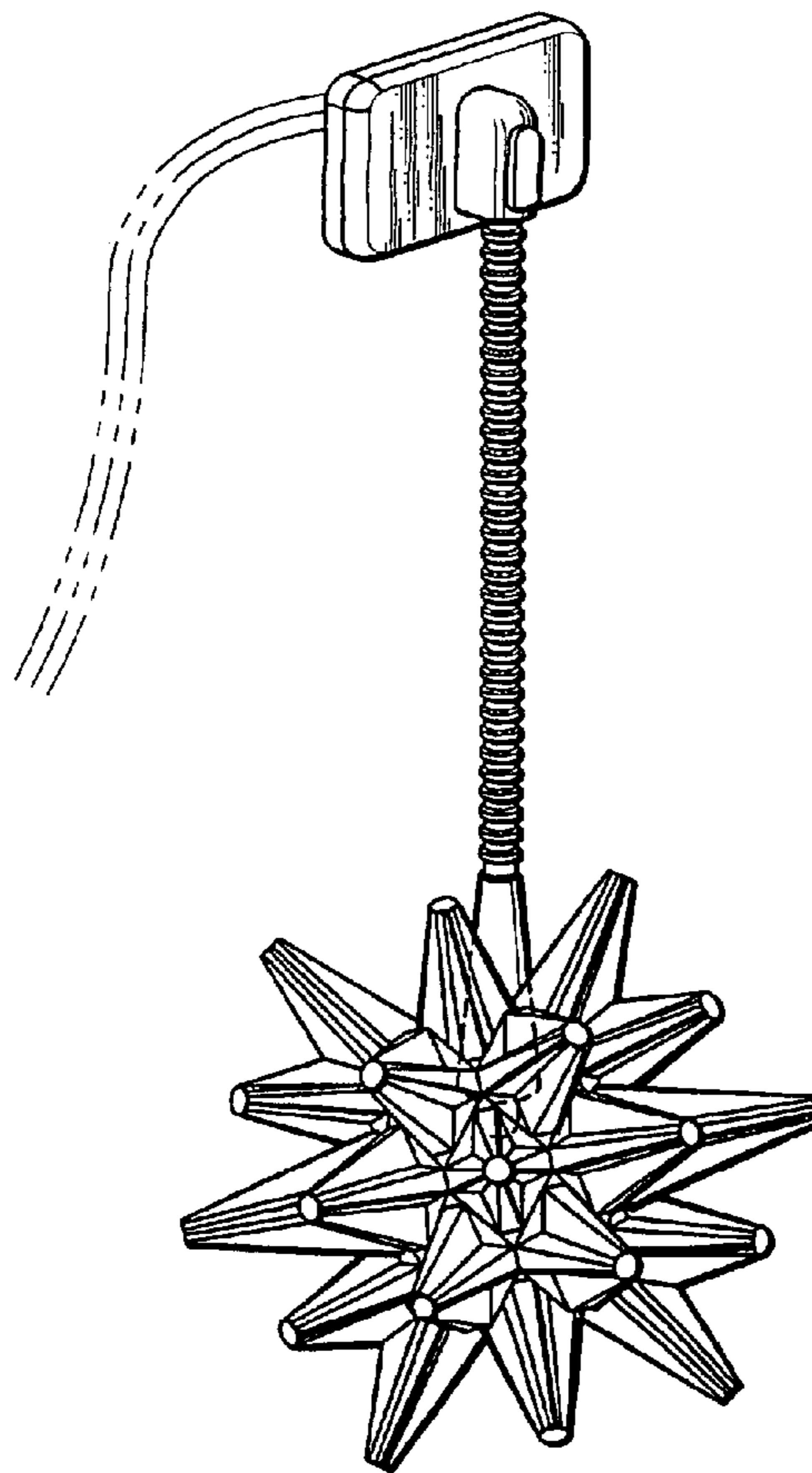

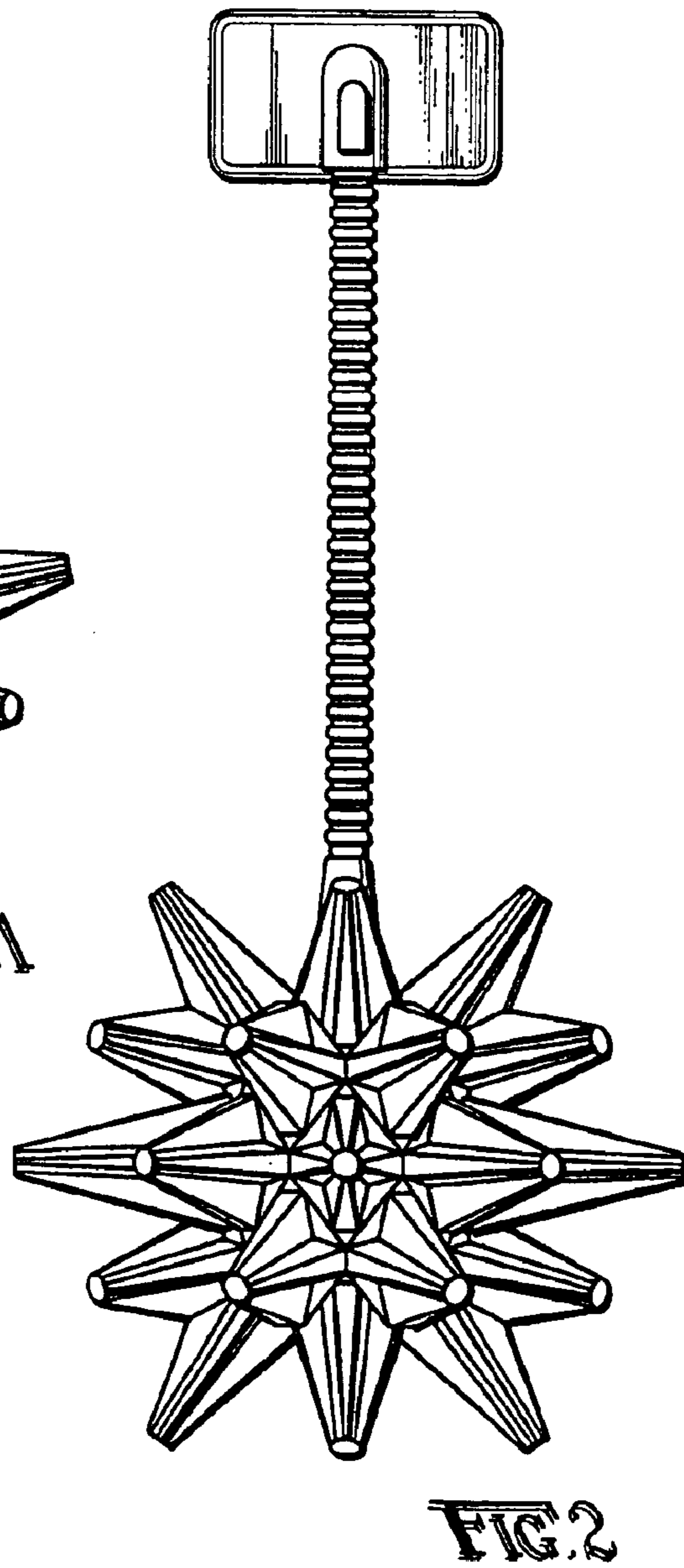
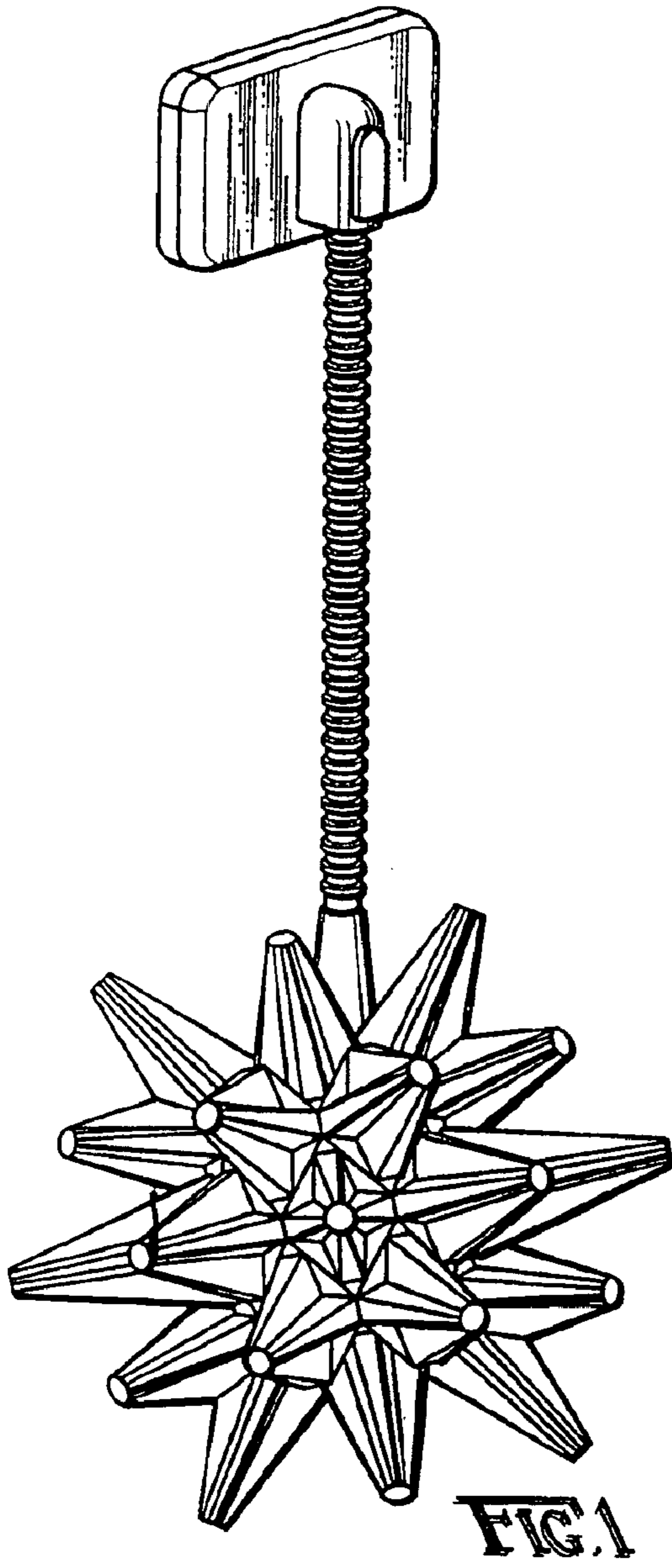

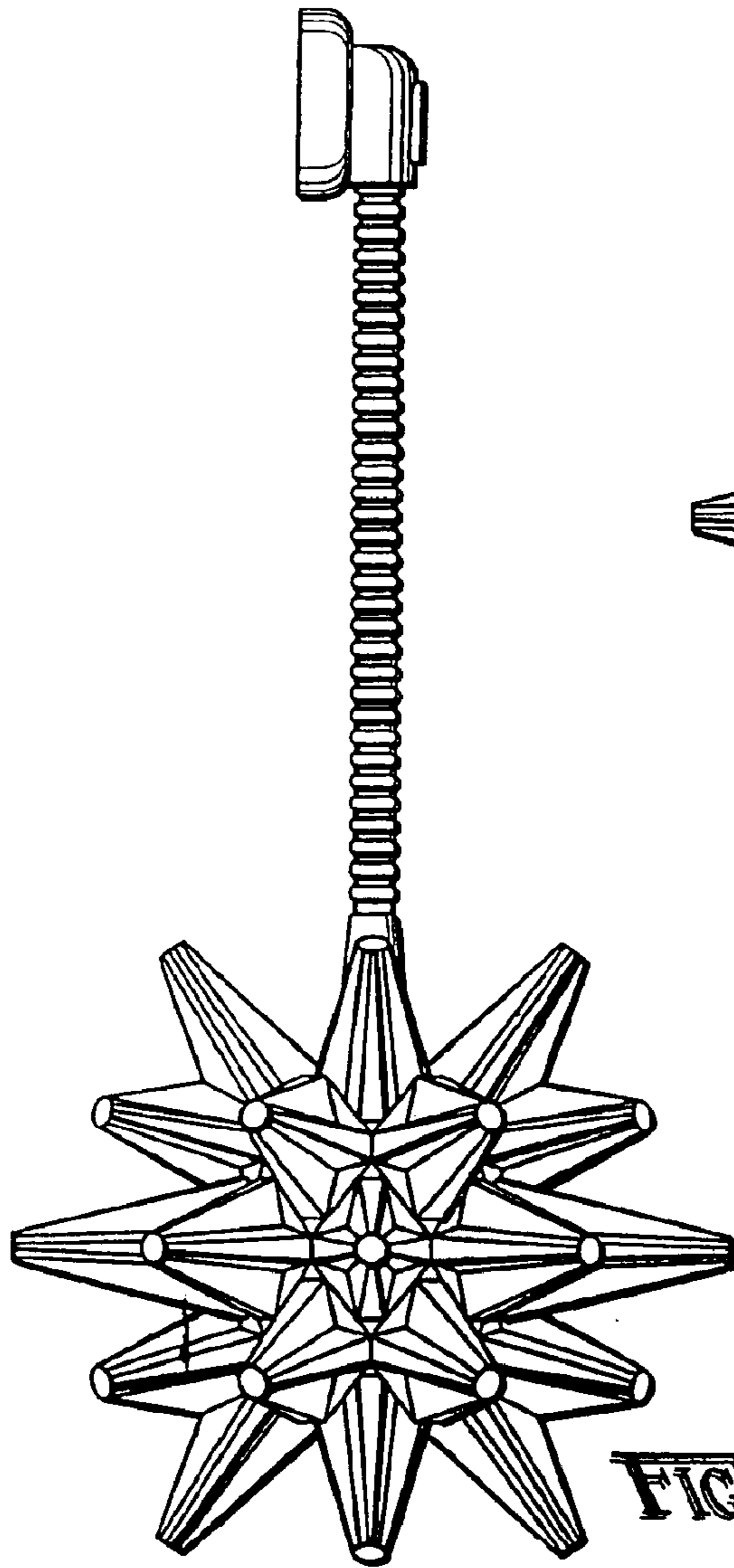

FIG. 3

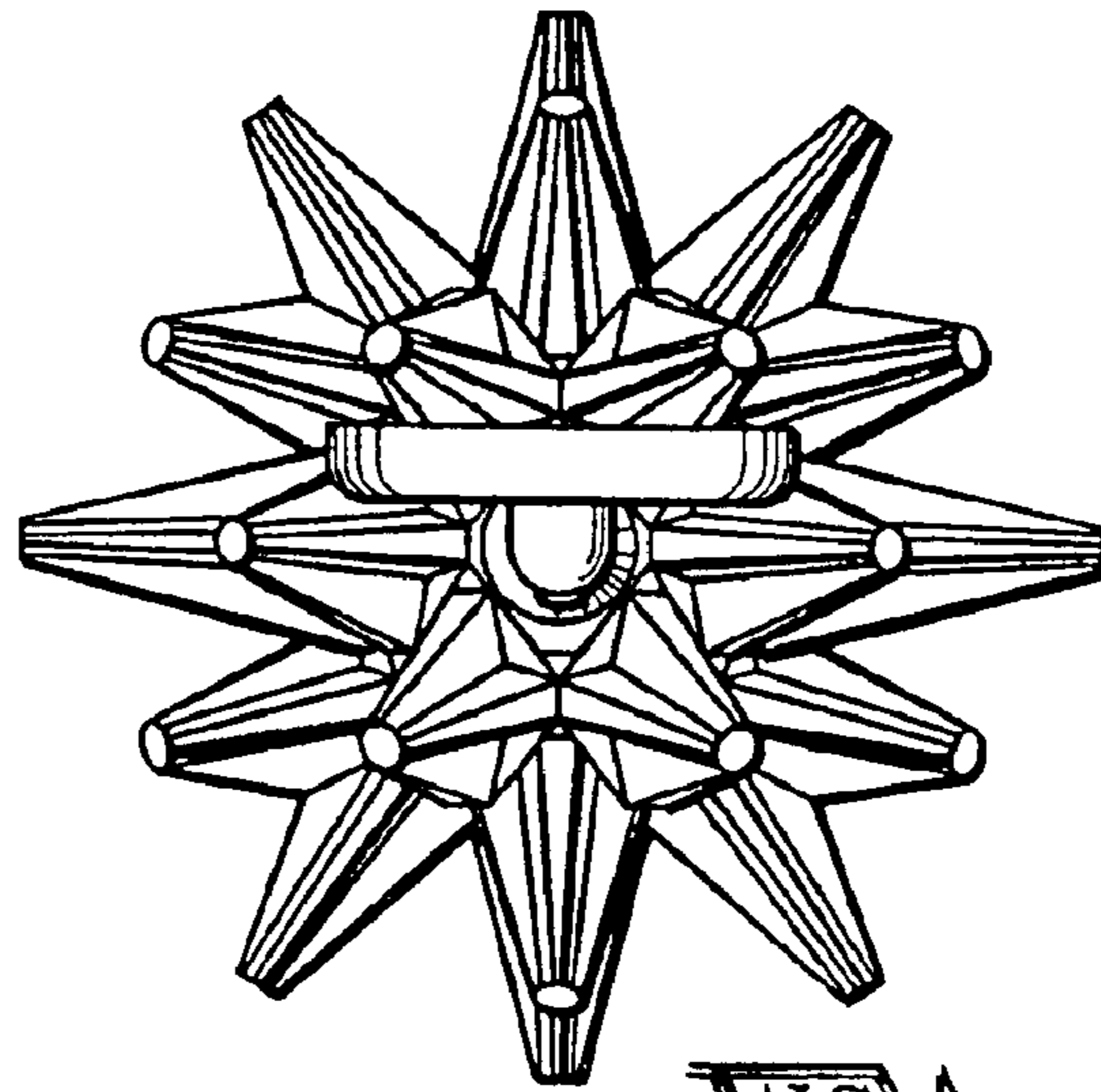

FIG. 4

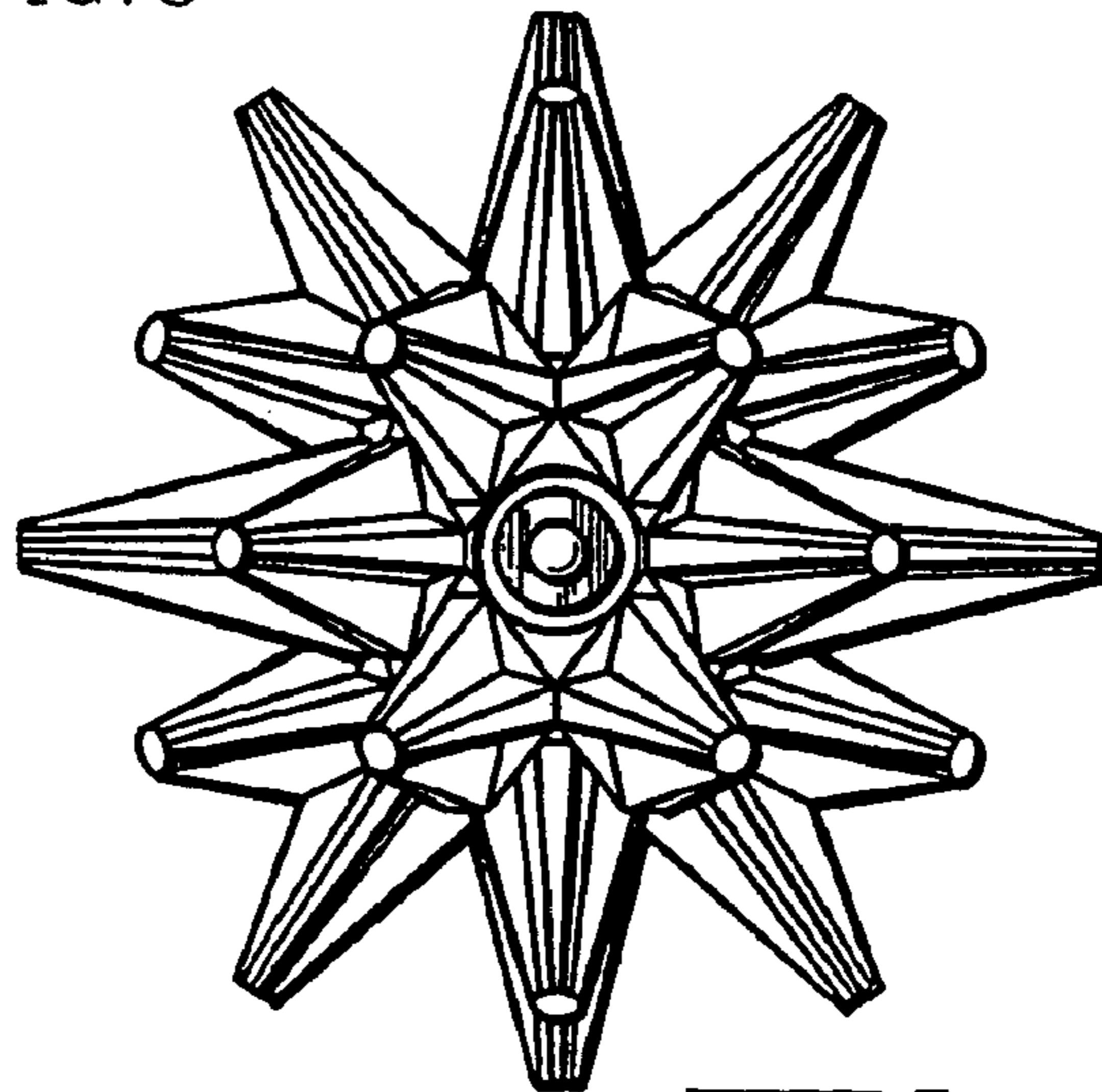

FIG. 5

