

US00D503554S

(12) **United States Design Patent**  
**Kay**

(10) **Patent No.:** **US D503,554 S**

(45) **Date of Patent:** **\*\* Apr. 5, 2005**

(54) **CHAIR**

(75) **Inventor:** **Neil J. Kay**, Rolling Hills, CA (US)

(73) **Assignee:** **Cisco Sales Corporation**, Torrance, CA (US)

(\*\*) **Term:** **14 Years**

(21) **Appl. No.:** **29/199,329**

(22) **Filed:** **Feb. 13, 2004**

(51) **LOC (7) Cl.** ..... **06-01**

(52) **U.S. Cl.** ..... **D6/358; D6/368**

(58) **Field of Search** ..... D6/334–336, 351, D6/361, 367, 368, 374, 375, 379, 500–502; D21/521, 788; 297/16.2, 45, 35, 46, 55, 56, 57, 59, 440.1, 440.11, 452.13, 188.01, 188.14, 188.18, 188.19, 181

(56) **References Cited**

**U.S. PATENT DOCUMENTS**

D354,642 S	*	1/1995	Stoddard et al.	.....	D6/450
5,499,857 A	*	3/1996	Lynch, Jr.	.....	297/16.2
D379,875 S	*	6/1997	Wied et al.	.....	D6/351
D382,413 S	*	8/1997	Lundberg	.....	D6/361
D382,414 S	*	8/1997	Lee	.....	D6/368
5,690,379 A	*	11/1997	Cayssials	.....	297/118

5,893,605 A	*	4/1999	Chang	.....	297/188.14
5,984,406 A	*	11/1999	Lee	.....	297/16.2
D432,325 S	*	10/2000	Zheng et al.	.....	D6/368
D432,823 S	*	10/2000	Zheng	.....	D6/500
6,547,322 B2	*	4/2003	Marx	.....	297/45
6,698,827 B2	*	3/2004	Le Gette et al.	.....	297/16.2

\* cited by examiner

*Primary Examiner*—Mimosa De

(74) *Attorney, Agent, or Firm*—Irving Keschner

(57) **CLAIM**

The ornamental design for a chair, as shown.

**DESCRIPTION**

FIG. 1 is a front elevational view of the chair of the present invention.

FIG. 2 is a back view of the chair of the present invention; FIG. 3 is a side view of the chair shown in FIG. 1, the other side being a mirror image thereof;

FIG. 4 is a top view of the chair shown in FIG. 1;

FIG. 5 is a bottom view of the chair shown in FIG. 1; and, FIG. 6 is a top view of the chair in FIG. 1 shown in a reclined condition.

The crosshatch shown in the drawing represents fabric and is understood to be repeated throughout the circumscribed areas. The broken line shown in FIG. 2 represents stitching.

**1 Claim, 5 Drawing Sheets**

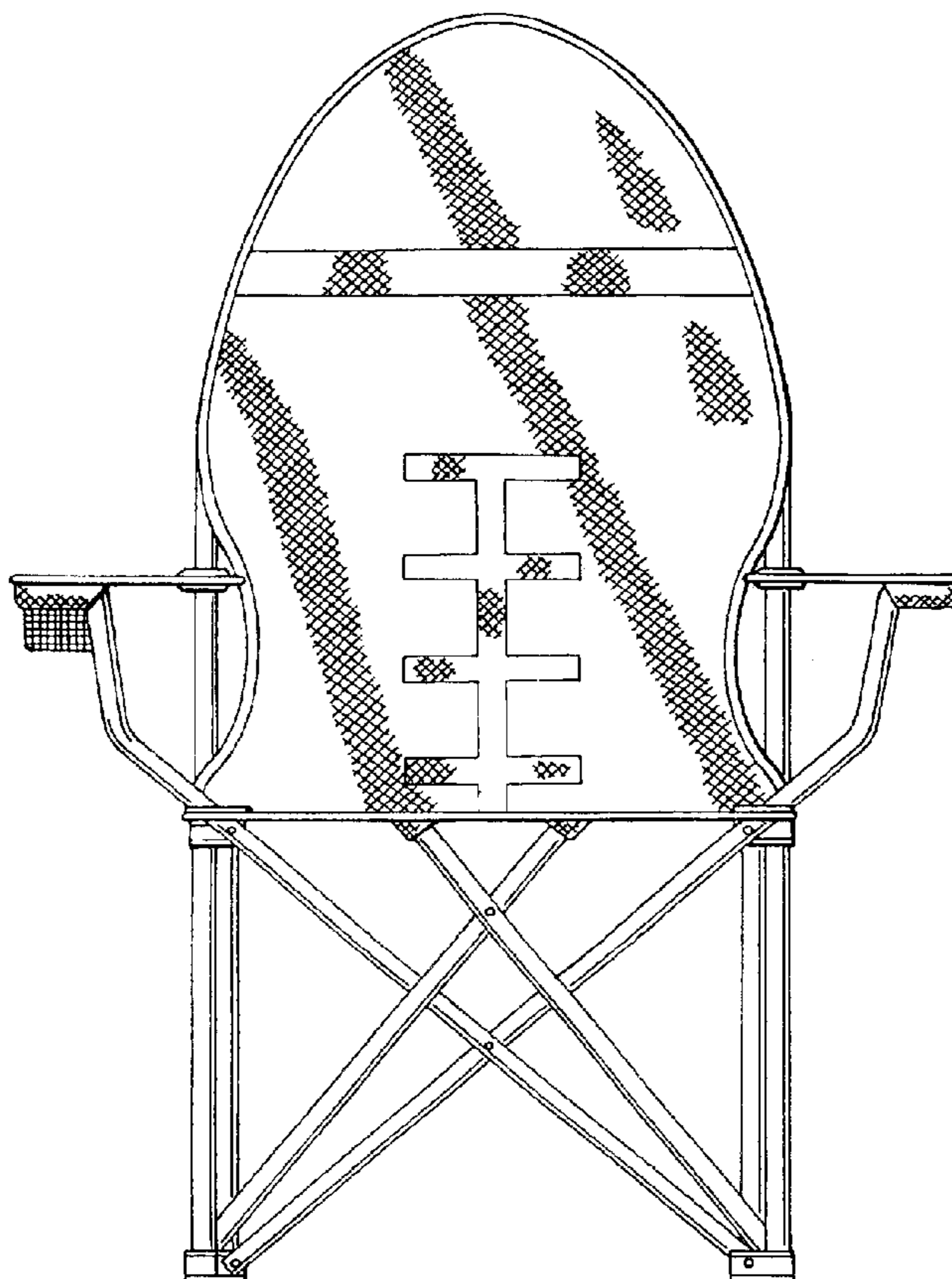

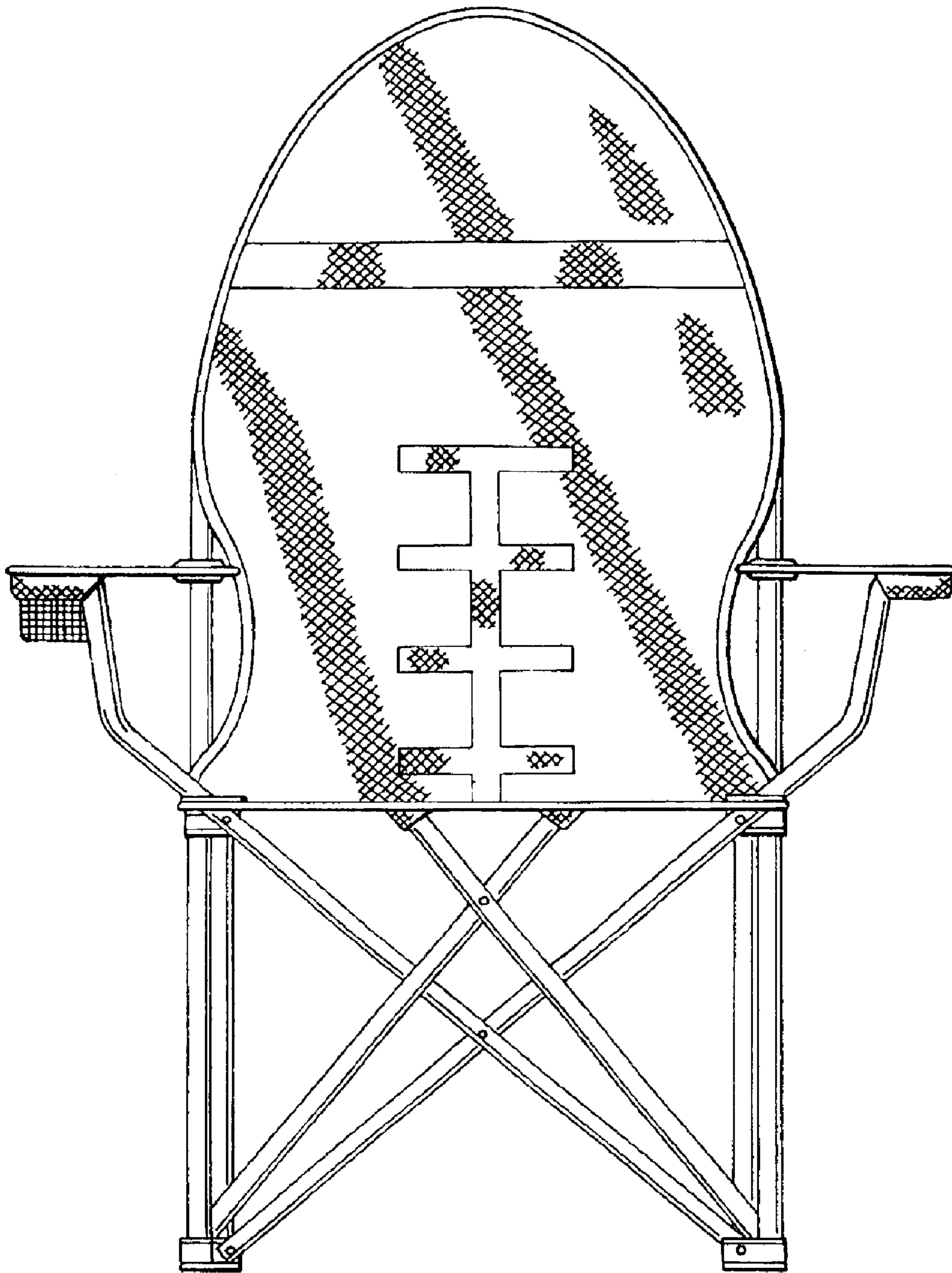

FIG. 1

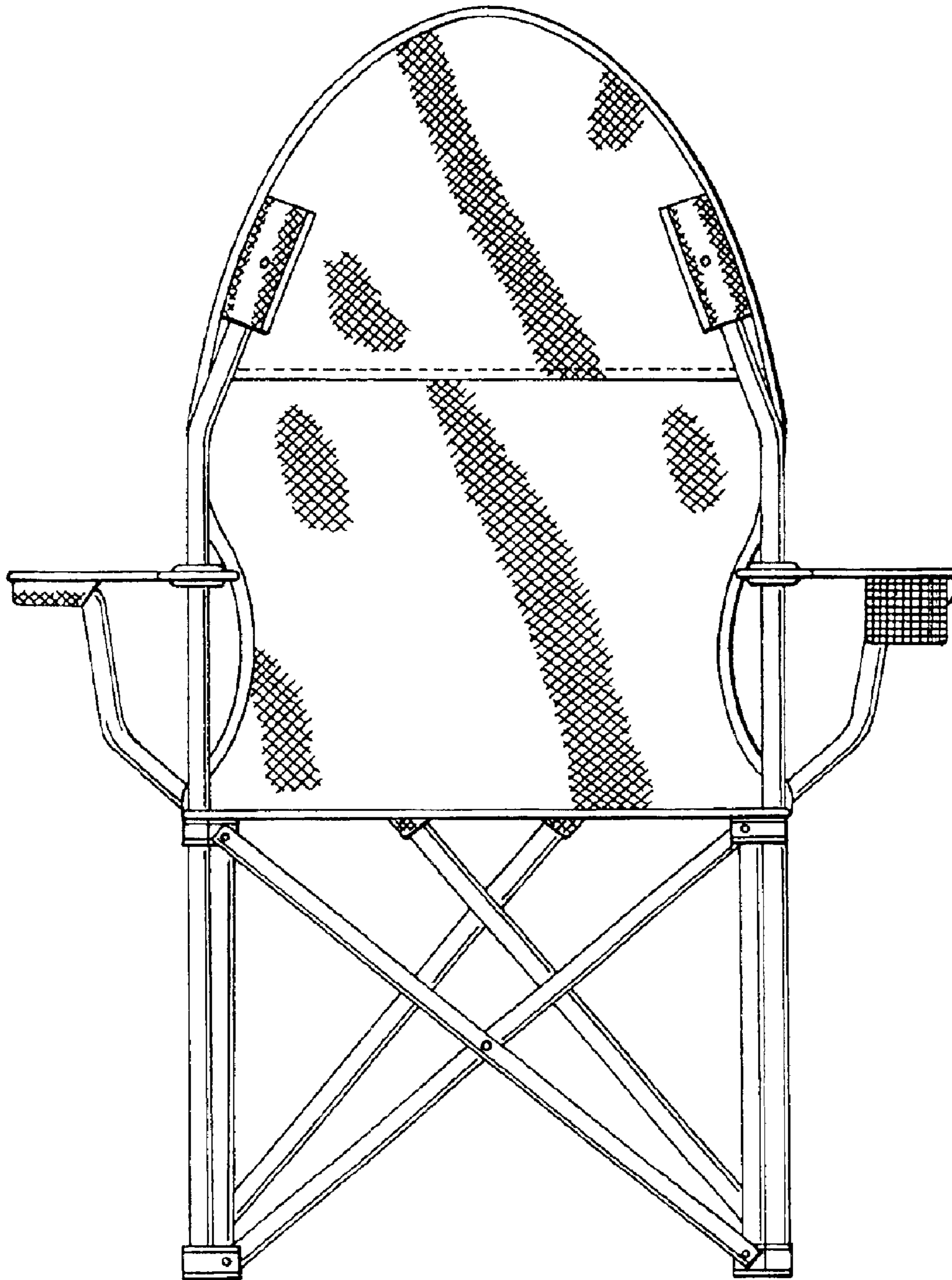

FIG. 2



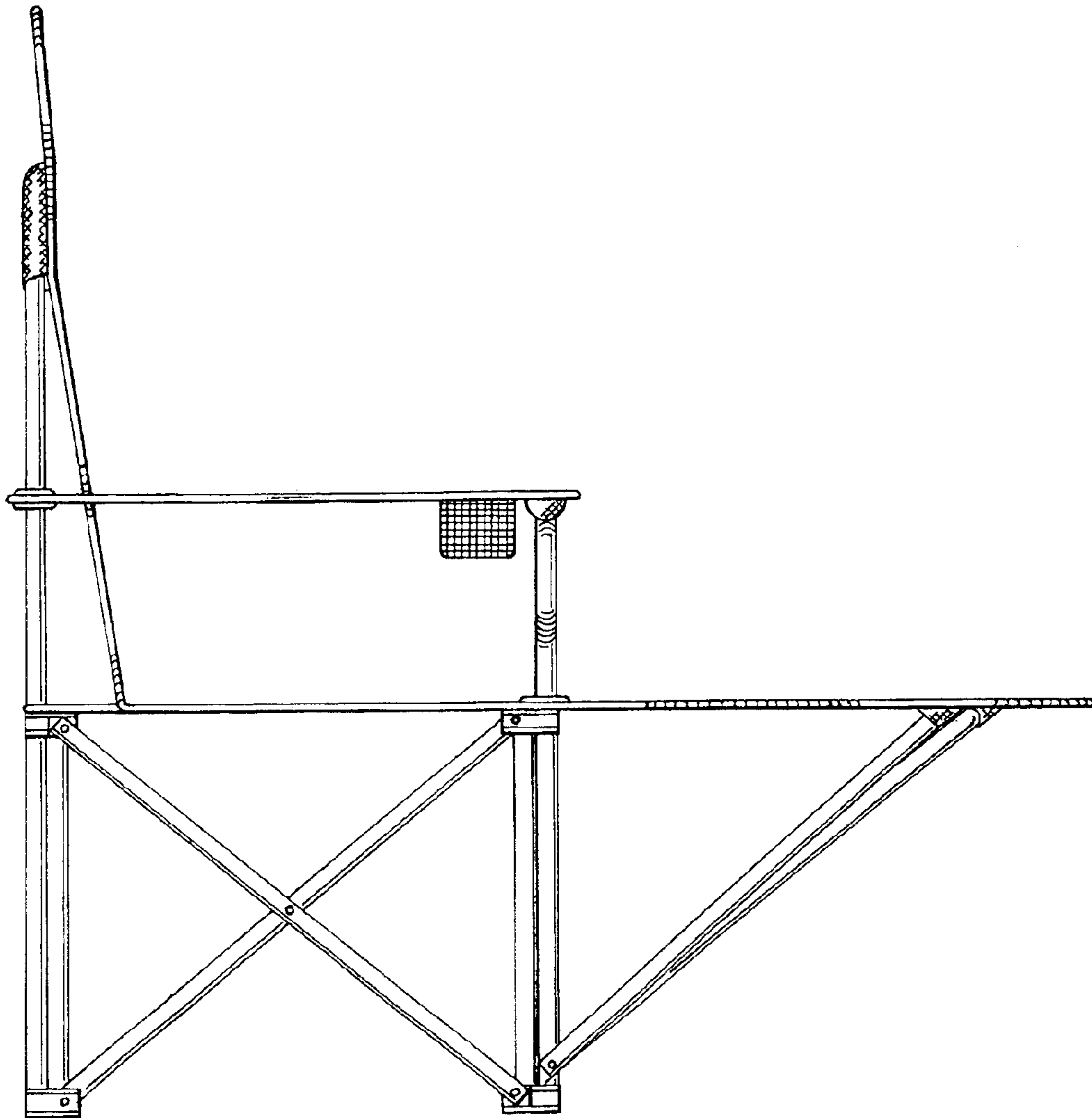

FIG. 3

FIG. 4

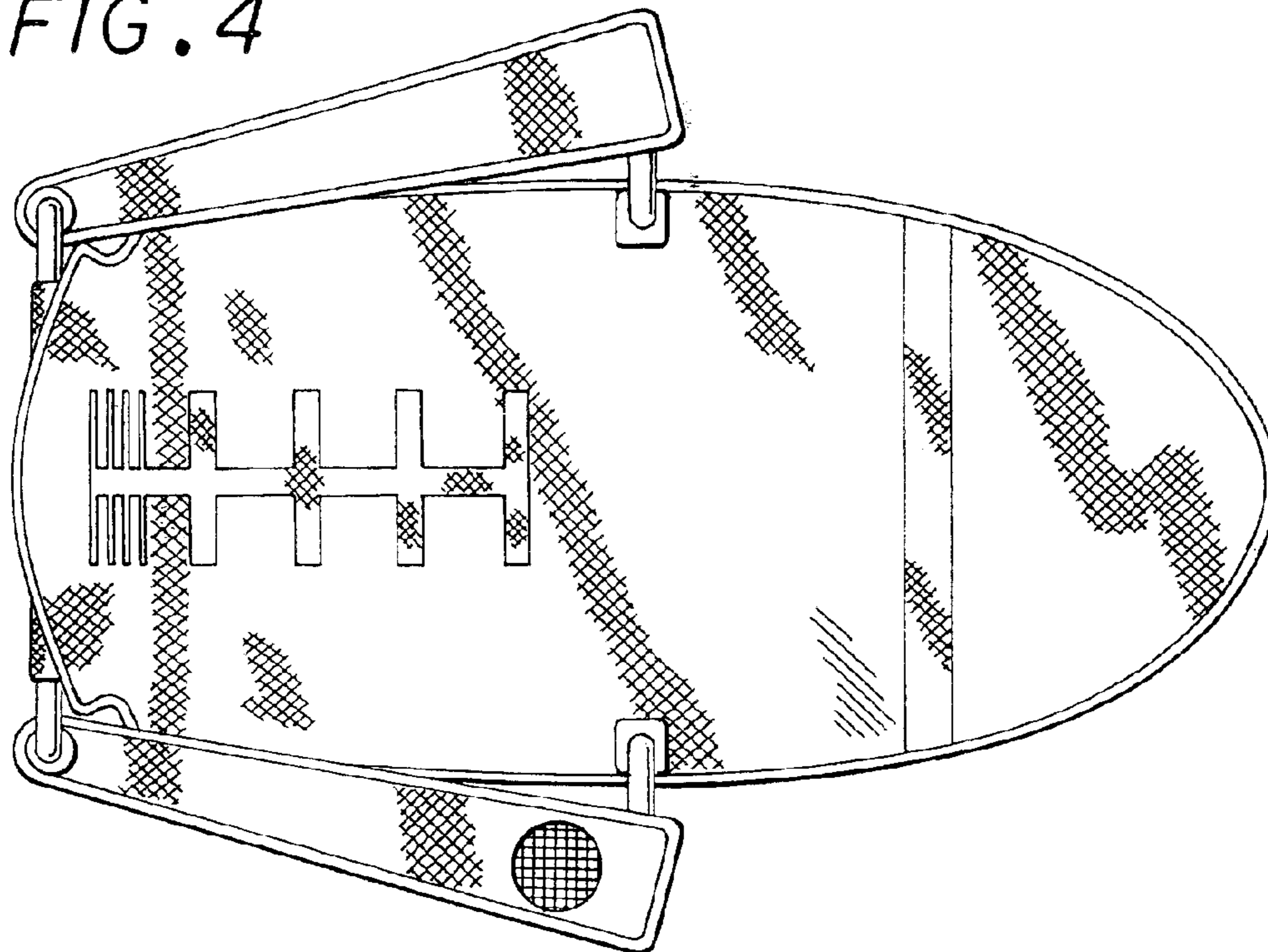
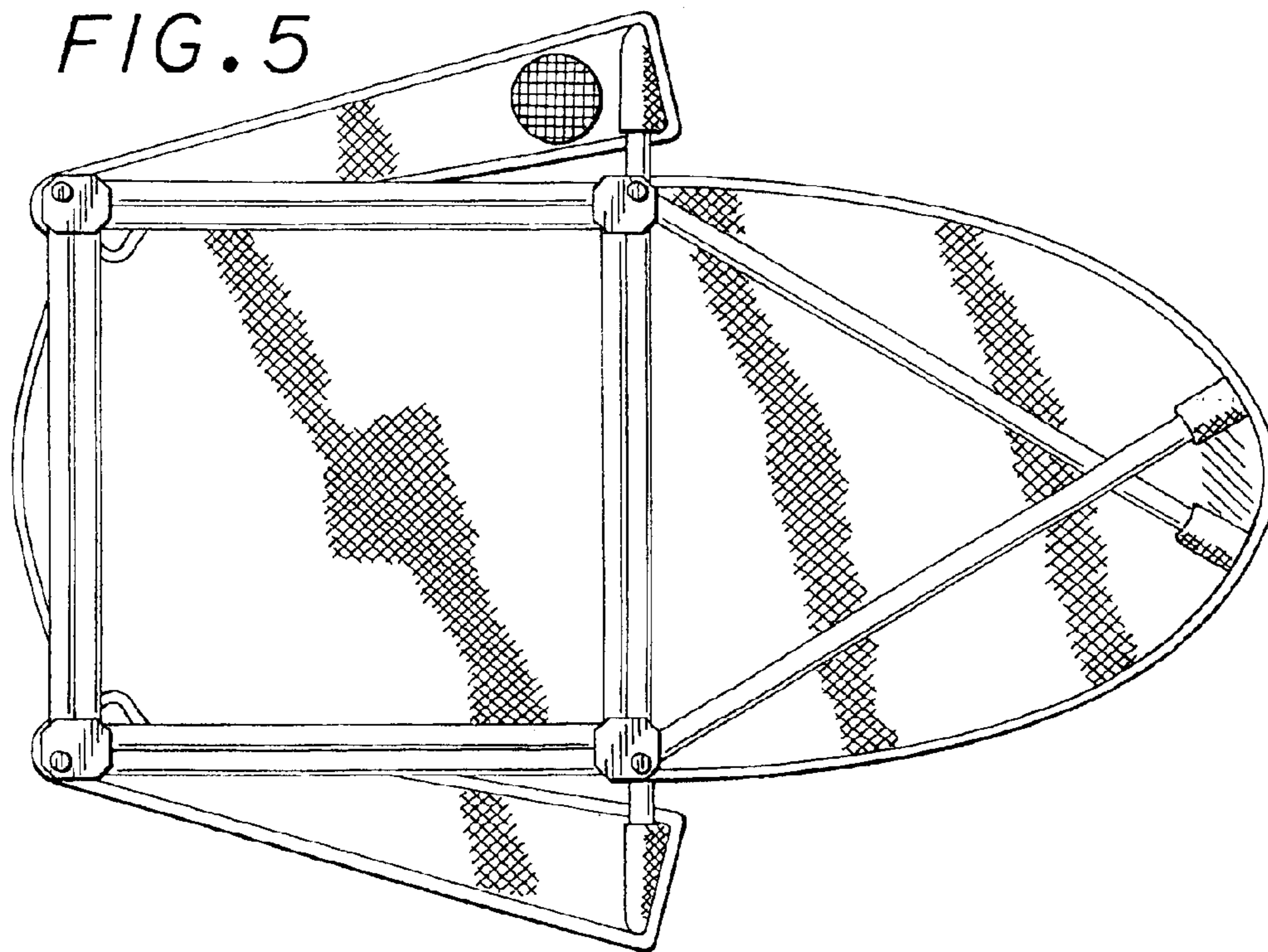

FIG. 5



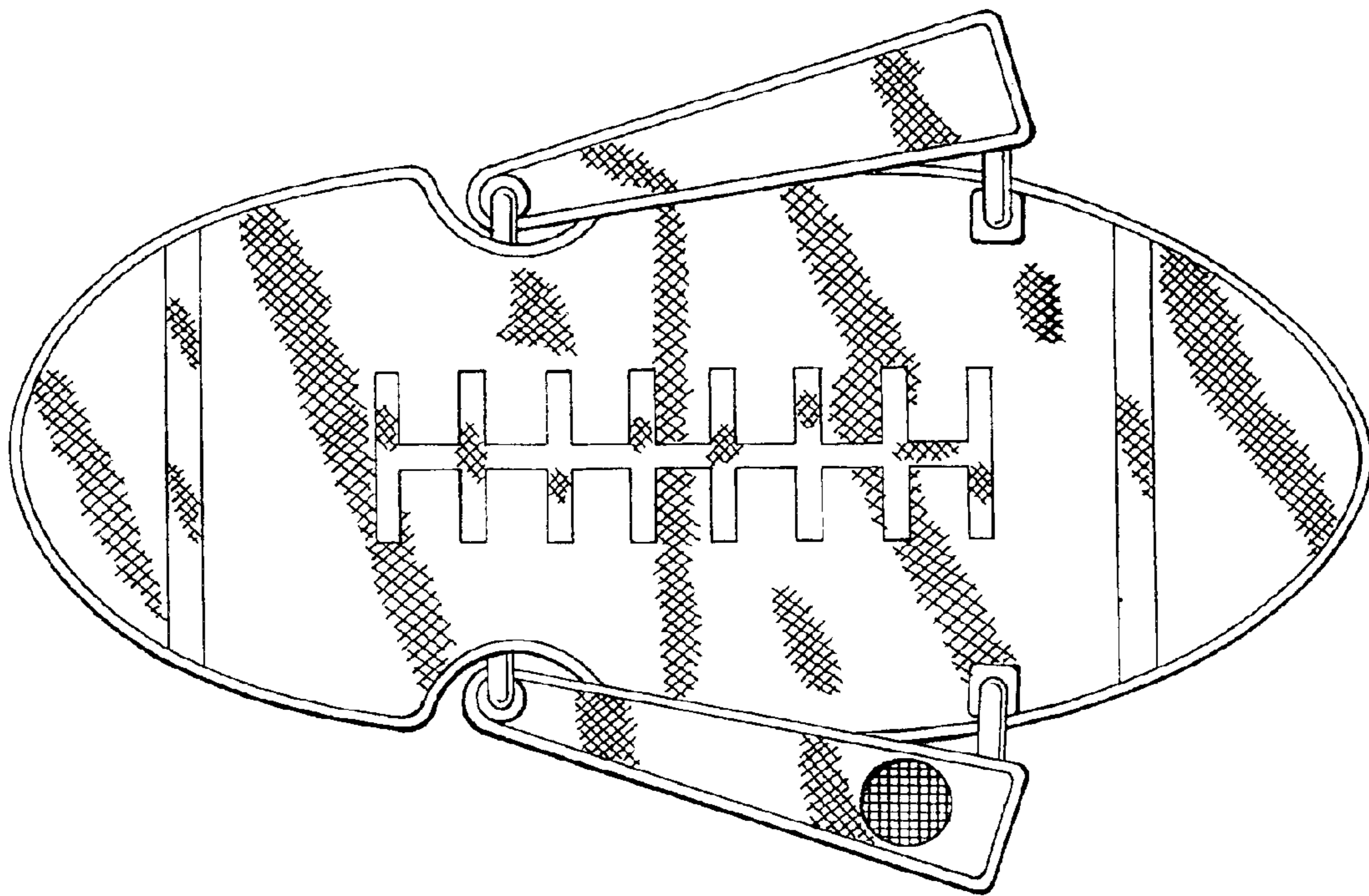

FIG. 6