

US00D503078S

(12) **United States Design Patent**
Sakai et al.

(10) **Patent No.:** **US D503,078 S**
(45) **Date of Patent:** **** Mar. 22, 2005**

(54) **PORTABLE ELECTRIC HAMMER DRILL**

(75) Inventors: **Masato Sakai**, Hitachinaka (JP);
Seiichi Kodato, Hitachinaka (JP);
Hiroshi Haga, Hitachinaka (JP);
Shingo Yamazaki, Hitachinaka (JP)

(73) Assignee: **Hitachi Koki Co., Ltd.**, Tokyo (JP)

(**) Term: **14 Years**

(21) Appl. No.: **29/175,170**

(22) Filed: **Jan. 31, 2003**

(30) **Foreign Application Priority Data**

Aug. 5, 2002 (JP) 2002-020801
Aug. 5, 2002 (JP) 2002-020804

(51) **LOC (7) Cl.** **08-01**

(52) **U.S. Cl.** **D8/69**

(58) **Field of Search** D8/61, 62, 63,
D8/64, 65, 66, 67, 68, 69, 70; 81/57.11,
429, 464, 465, 466, 469, 489; 173/13, 169,
178, 213, 217; 227/8, 114, 120, 130, 136,
142; 310/50; 408/20, 124, 125, 234, 241 R;
451/358

(56) **References Cited**

U.S. PATENT DOCUMENTS

3,919,573 A * 11/1975 Schmuck 310/50
4,260,916 A * 4/1981 Theissig 310/50
4,365,962 A * 12/1982 Regelsberger 173/178
4,366,403 A * 12/1982 Simpson et al. 310/50
4,378,053 A * 3/1983 Simpson 173/13
4,967,888 A * 11/1990 Lippacher et al. 173/178

D320,918 S * 10/1991 Mochida D8/68
D349,029 S * 7/1994 Matsunaga et al. D8/69
D361,252 S * 8/1995 De Neergaard et al. D8/68
D377,591 S * 1/1997 Hattori D8/68
D386,379 S * 11/1997 Kasuya D8/69
D395,586 S * 6/1998 Arakawa et al. D8/69
D440,849 S * 4/2001 Sakai et al. D8/69
D440,851 S * 4/2001 Sakai et al. D8/69
D447,032 S * 8/2001 Schoen et al. D8/67
6,412,572 B2 * 7/2002 Habedank et al. 310/50
D466,780 S * 12/2002 Stirm D8/69
D474,092 S * 5/2003 Stirm D8/69

OTHER PUBLICATIONS

Hammer kits, p. 39, DeWalt Tool catalogue, c. 1998.*

* cited by examiner

Primary Examiner—Joel A. Sincavage

Assistant Examiner—T. Chase Nelson

(74) *Attorney, Agent, or Firm*—Sughrue Mion, PLLC

(57) **CLAIM**

The ornamental design for a portable electric hammer drill, as shown.

DESCRIPTION

FIG. 1 is a perspective view of the top, rear and right side of a portable electric hammer drill showing our new design; FIG. 2 is a right side elevational view thereof; FIG. 3 is a left side elevational view thereof; FIG. 4 is a front elevational view thereof; FIG. 5 is a rear elevational view thereof; FIG. 6 is a top plan view thereof; and, FIG. 7 is a bottom plan view thereof.

1 Claim, 5 Drawing Sheets

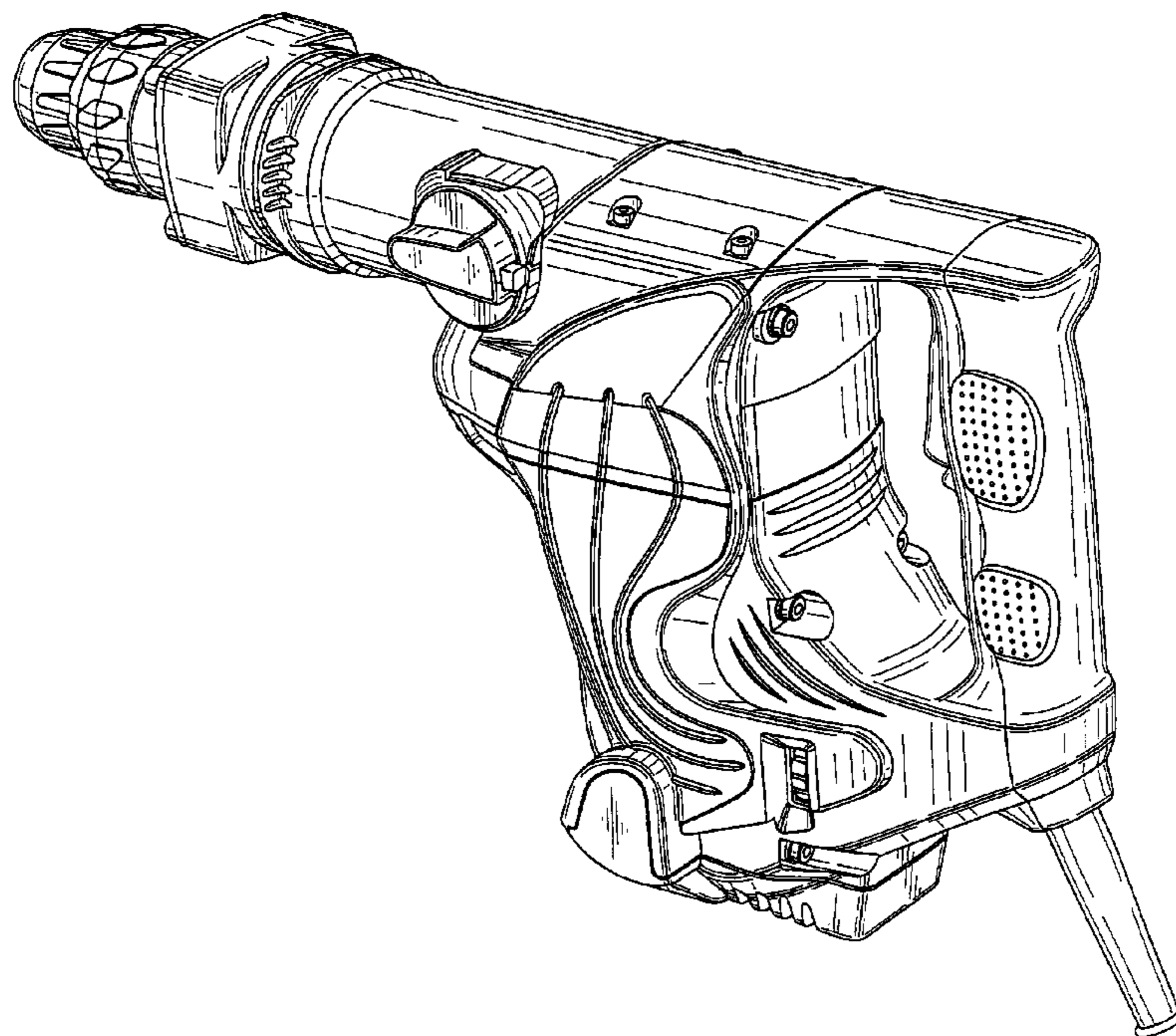

FIG. 1

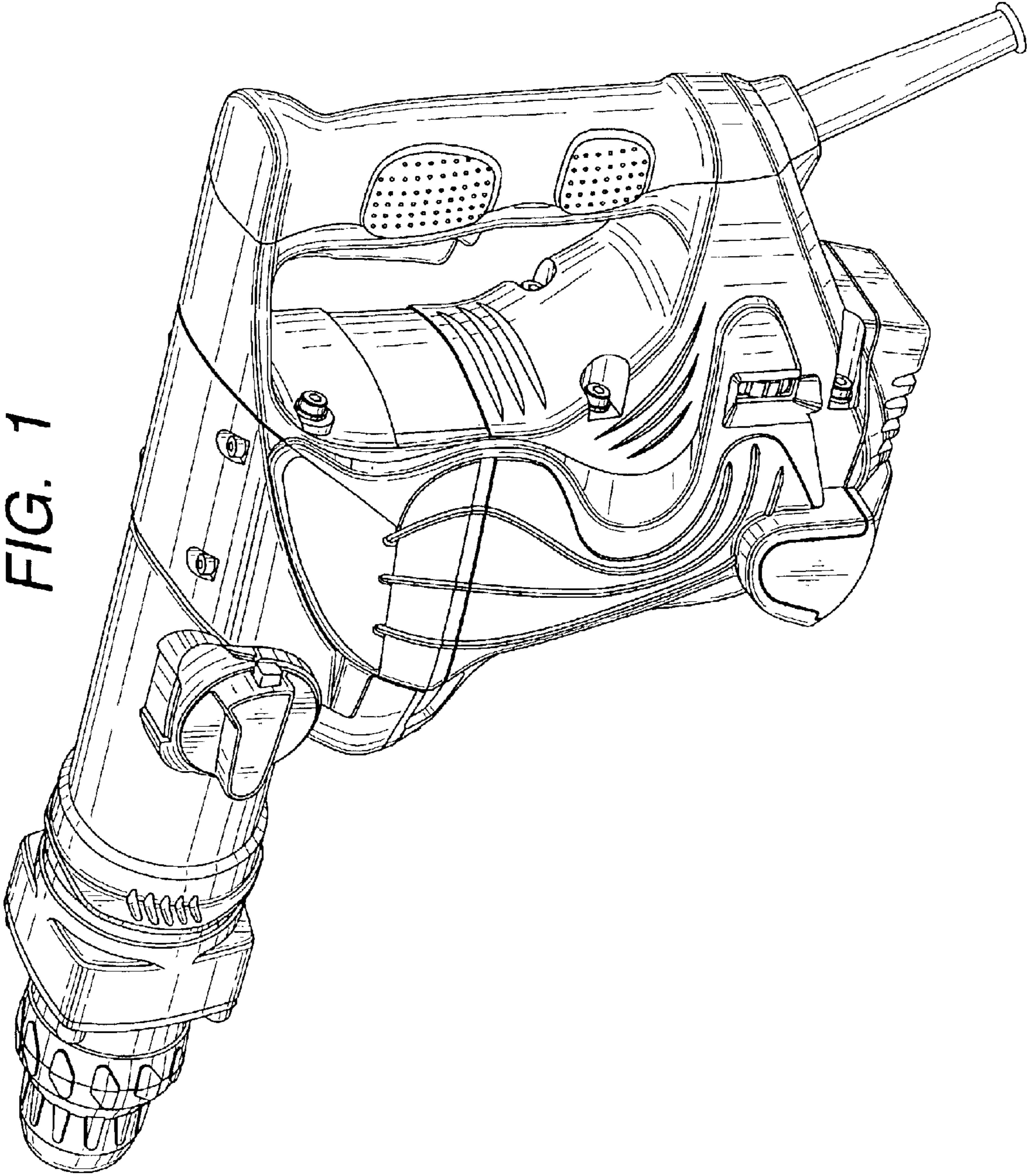

FIG. 2

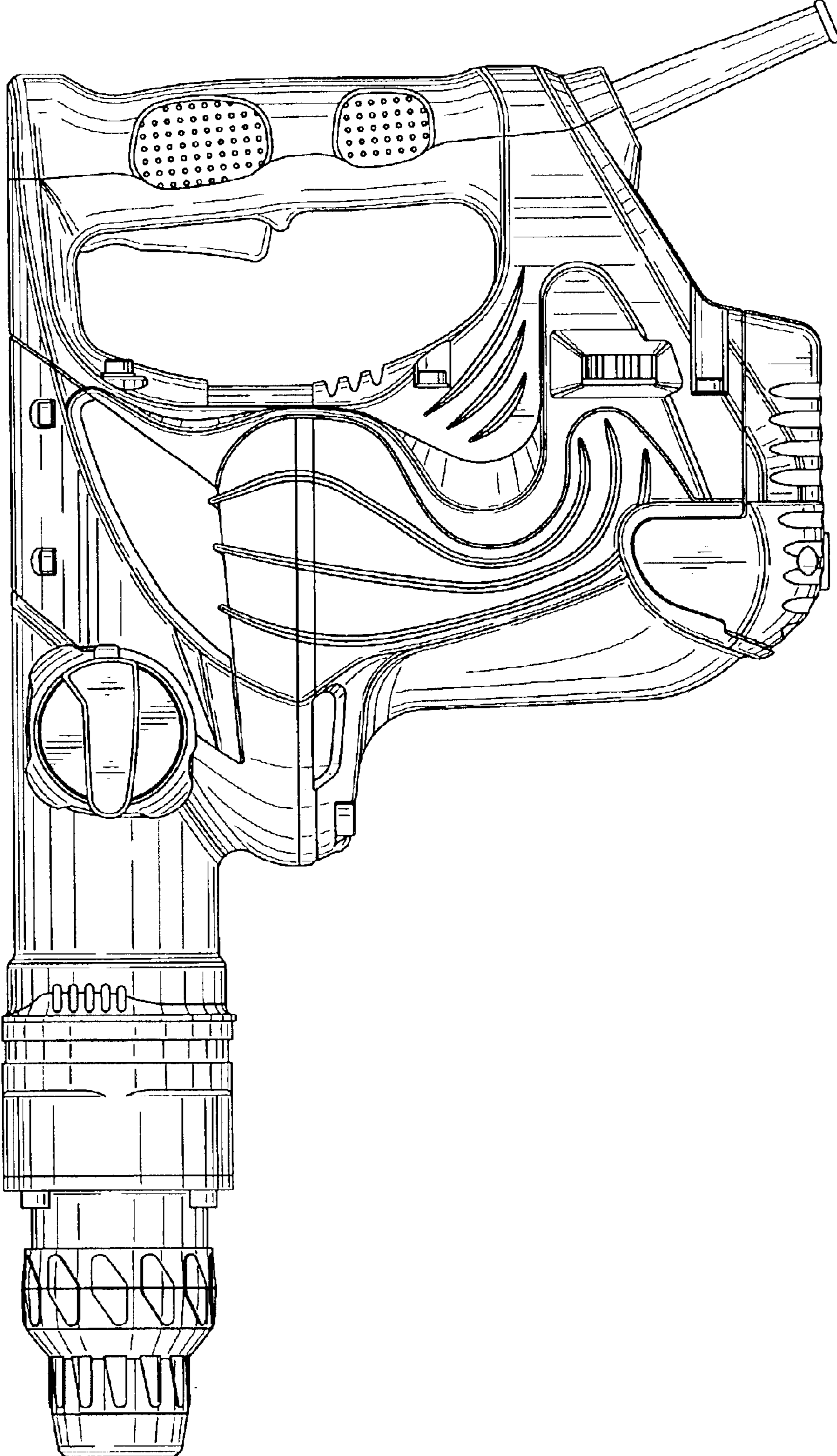

FIG. 3

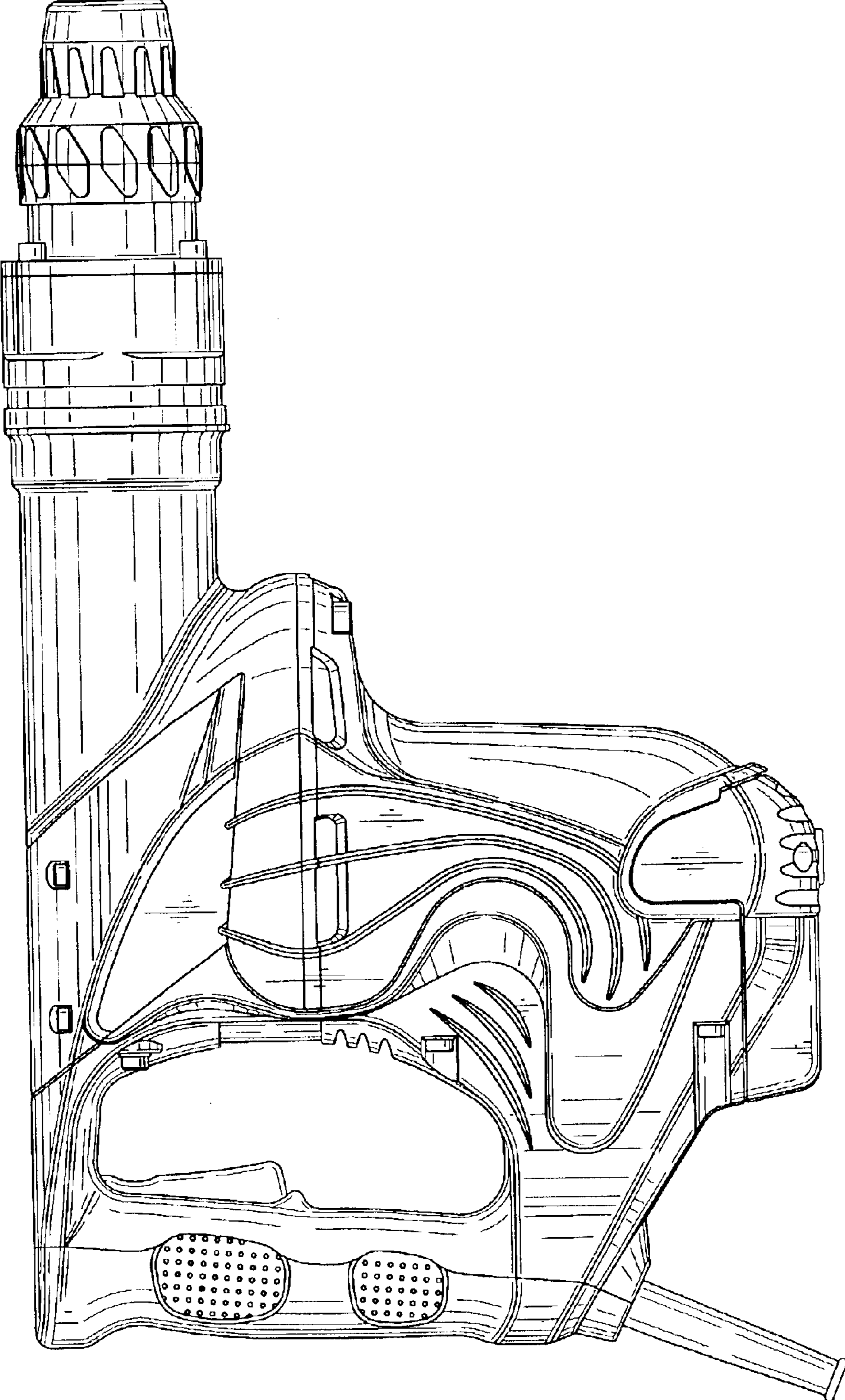

FIG. 4

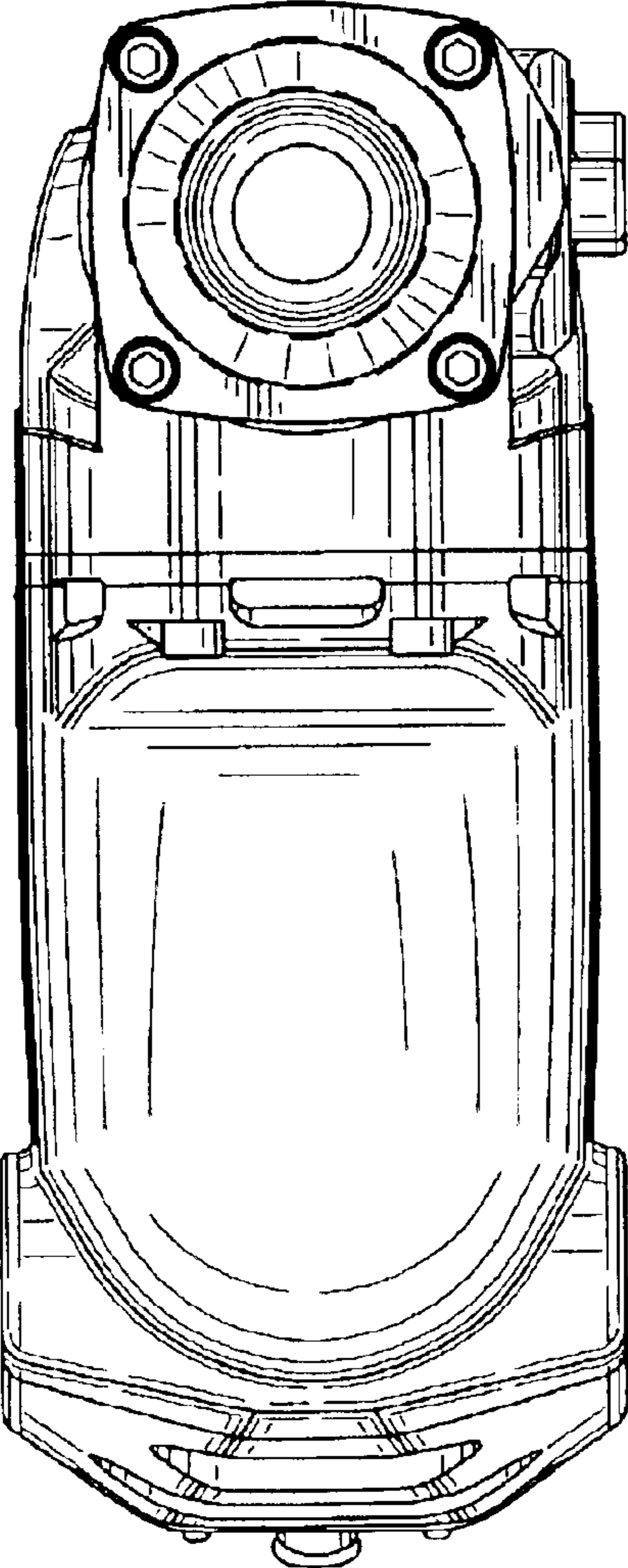

FIG. 5

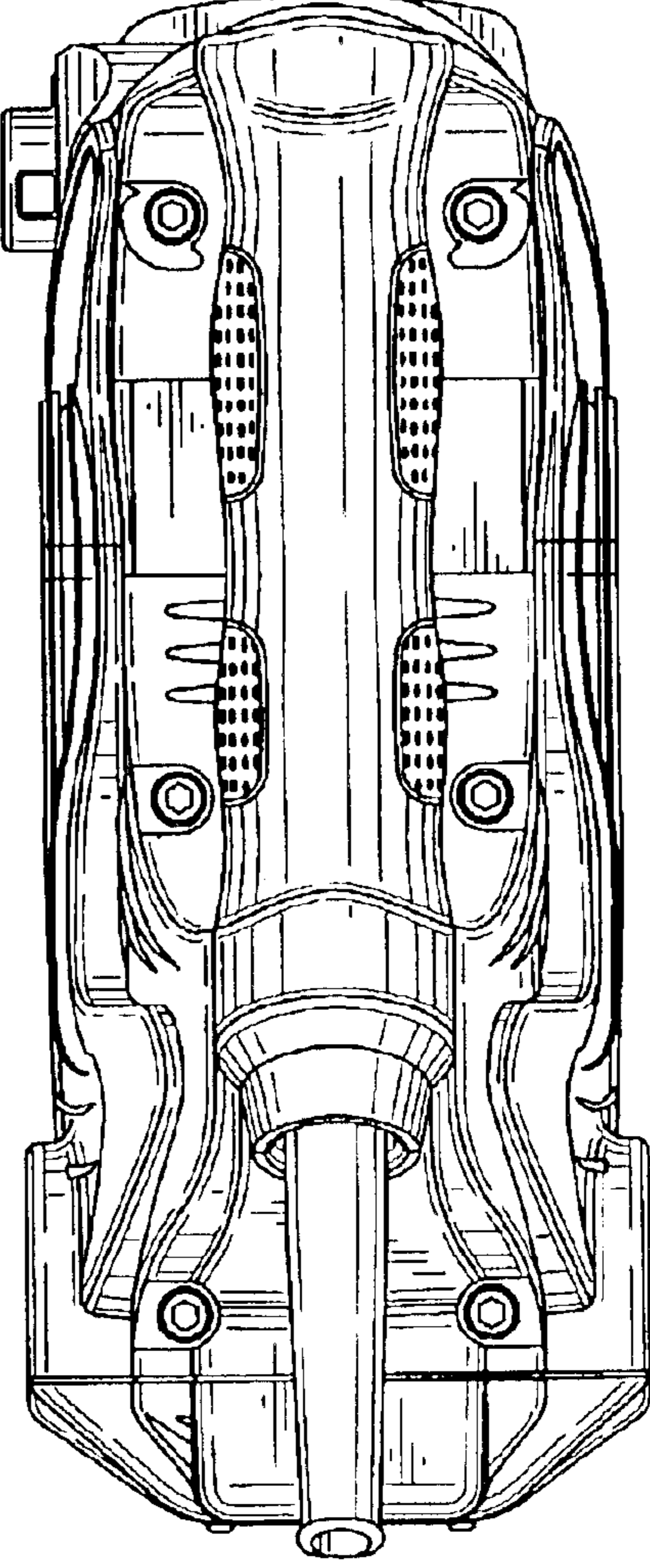

FIG. 6

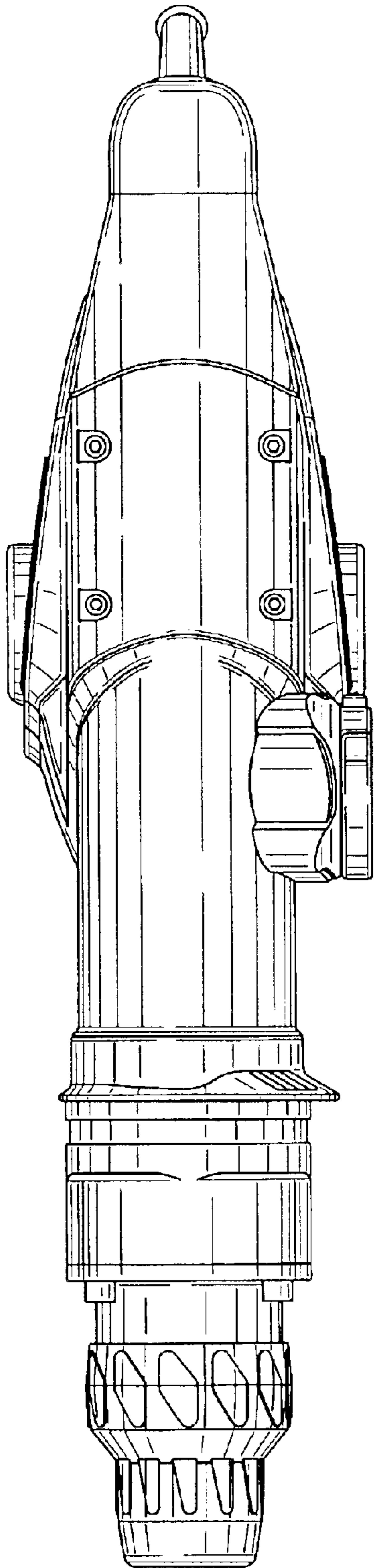

FIG. 7

