

US00D502894S

(12) **United States Design Patent**
Matthies

(10) **Patent No.:** **US D502,894 S**
(45) **Date of Patent:** **** Mar. 15, 2005**

(54) **TWO-SLOT ADAPTER FOR MOTORCYCLE-TO-TRIKE CONVERSION KIT**

(76) **Inventor:** **Lawayne Matthies**, 1888 Mountain Creek Pkwy., Dallas, TX (US) 75211

(**) **Term:** **14 Years**

(21) **Appl. No.:** **29/202,650**

(22) **Filed:** **Apr. 2, 2004**

(51) **LOC (7) Cl.** **12-11**

(52) **U.S. Cl.** **D12/114**

(58) **Field of Search** D12/111, 114, D12/223, 159-162, 106; D8/16, 19, 349, 380, 354, 366, 371, 373; 280/288.4, 477, 502, 504, 511; 248/200, 300

(56) **References Cited**

U.S. PATENT DOCUMENTS

D243,655 S	*	3/1977	Matousek et al.	D8/354
5,529,141 A	*	6/1996	Lehman et al.	180/209
D427,888 S	*	7/2000	Hannon	D8/354

* cited by examiner

Primary Examiner—Alan P. Douglas

Assistant Examiner—Linda Brooks

(74) *Attorney, Agent, or Firm*—James E. Walton

(57) **CLAIM**

The ornamental design for a two-slot adapter for motorcycle-to-trike conversion kit, as shown and described.

DESCRIPTION

FIG. 1 is a perspective view of the two-slot adapter for motorcycle-to-trike conversion kit according to the present invention.

FIG. 2 is a front view of the two-slot adapter for motorcycle-to-trike conversion kit according to the present invention. The rear view is a mirror image of the front view.

FIG. 3 is a right side view of the two-slot adapter for motorcycle-to-trike conversion kit according to the present invention.

FIG. 4 is a left side view of the two-slot adapter for motorcycle-to-trike conversion kit according to the present invention.

FIG. 5 is a top view of the two-slot adapter for motorcycle-to-trike conversion kit according to the present invention; and,

FIG. 6 is a bottom view of the two-slot adapter for motorcycle-to-trike conversion kit according to the present invention.

The broken lines in all views are for illustrative purposes only and form no part of the claimed design.

1 Claim, 2 Drawing Sheets

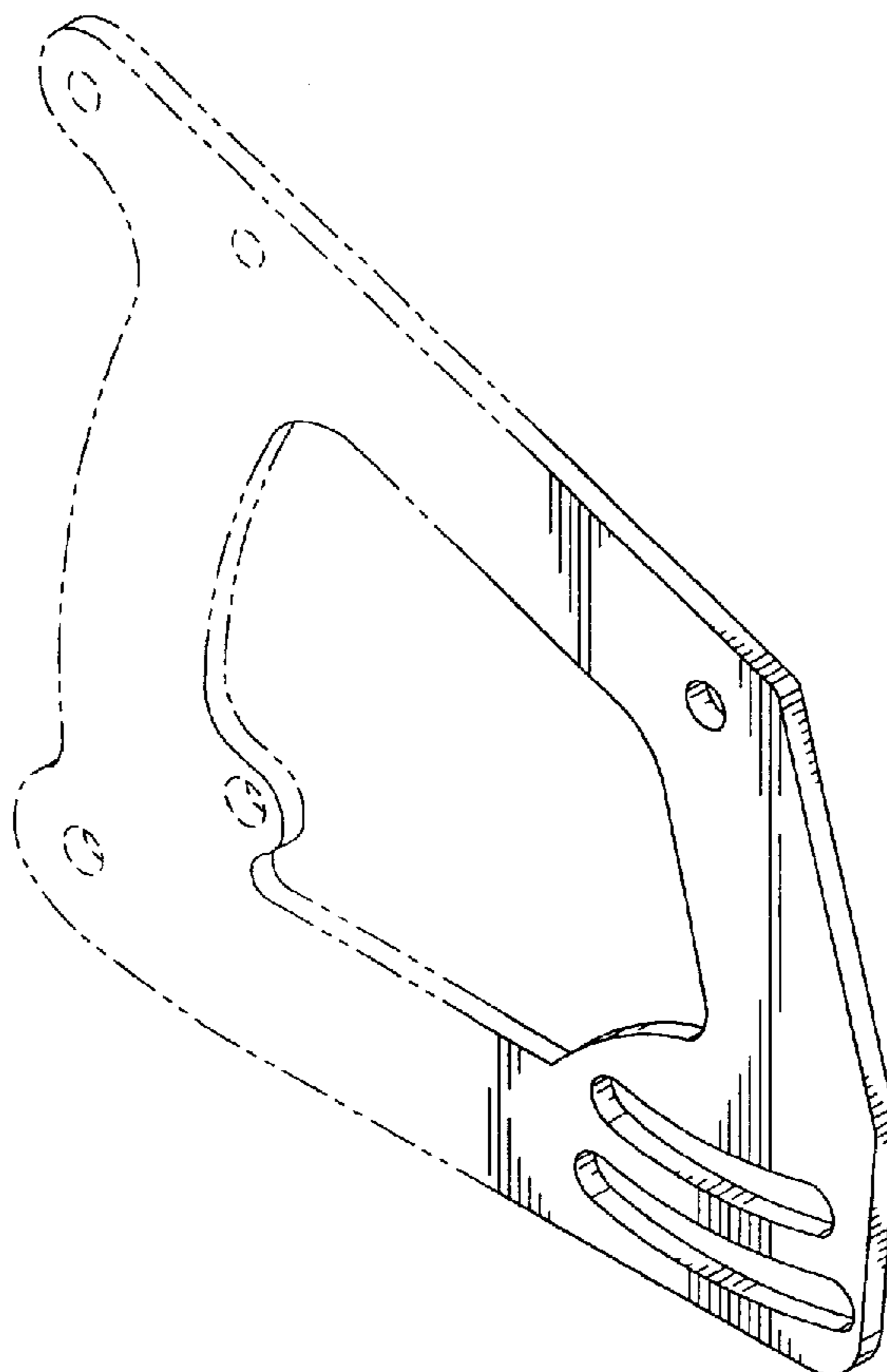

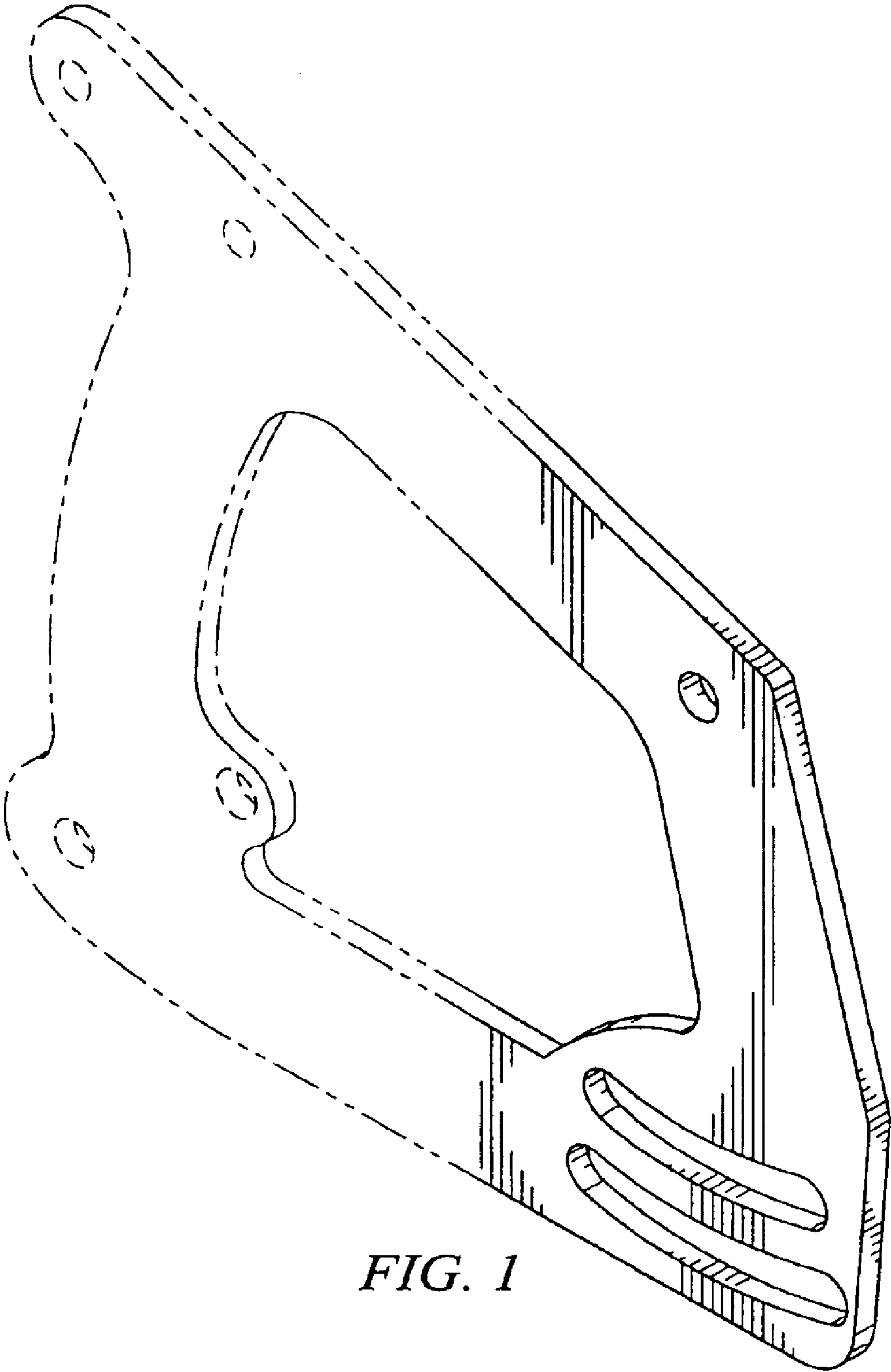

FIG. 1

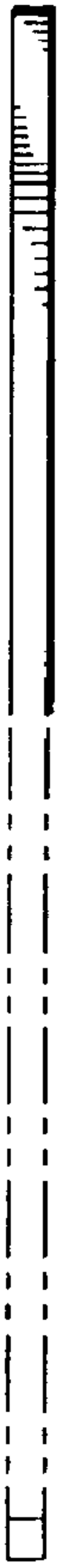

FIG. 5



FIG. 3

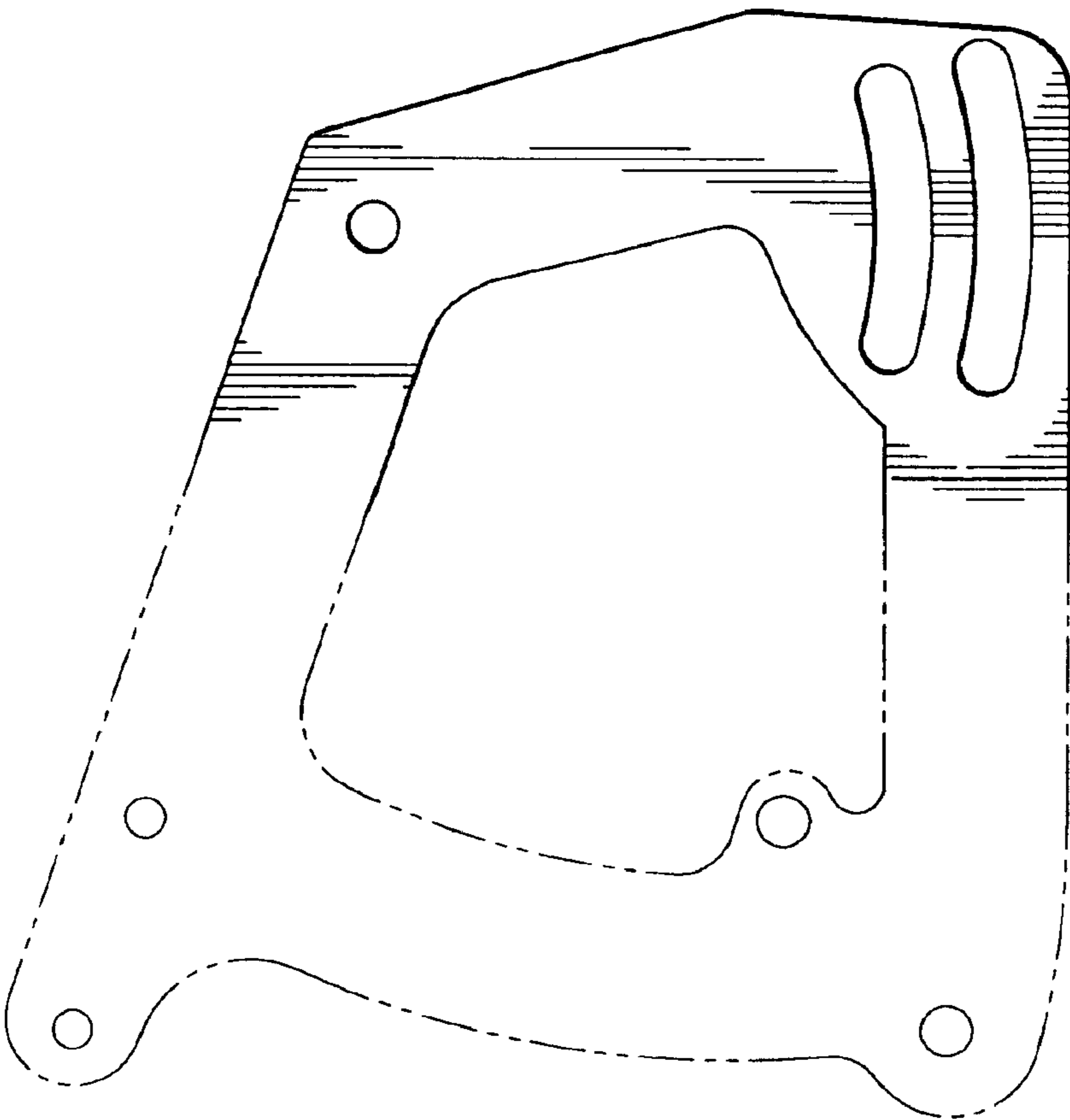

FIG. 2

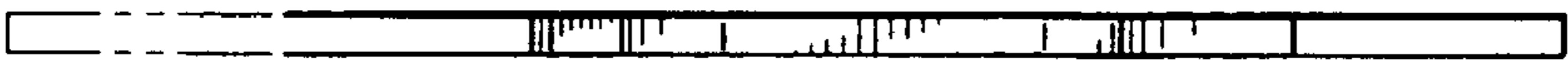

FIG. 4

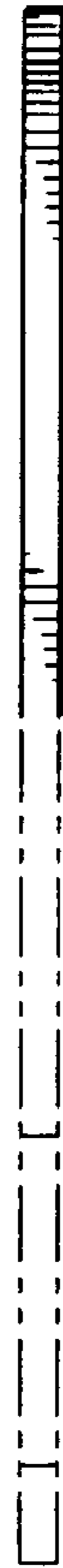

FIG. 6