



US00D502816S

(12) **United States Design Patent**  
**Bellington**

(10) **Patent No.: US D502,816 S**  
(45) **Date of Patent: \*\* Mar. 15, 2005**

(54) **BOAT SEAT**

**DESCRIPTION**

- (75) Inventor: **Bruce M. Bellington**, Loan Jack, MO (US)
- (73) Assignee: **Action Products Company**, Odessa, MO (US)
- (\*\*) Term: **14 Years**
- (21) Appl. No.: **29/186,112**
- (22) Filed: **Jul. 9, 2003**
- (51) **LOC (7) Cl.** ..... **06-01**
- (52) **U.S. Cl.** ..... **D6/356**
- (58) **Field of Search** ..... D6/334-336, 356, D6/366, 367, 368, 374, 376, 380, 500-502; 297/378.1, 378.12, 378.14, 452.18, 452.21, 452.29, 452.38, DIG. 2; 114/363

FIG. 1 is a front perspective view of a boat seat embodying my design, with various fasteners, the hinge flanges and pins, and a number of other constructional details being shown in broken lines for illustrative purposes only and forming no part of the claimed design;

FIG. 2 is a front elevation view of the boat seat depicted in FIG. 1, further illustrating the support post and rotatable seat pedestal in broken lines for illustrative purposes only so as not to form any part of the claimed design;

FIG. 3 is a left side elevation view of the boat seat depicted in FIGS. 1 and 2, with the right side elevation being a mirror image thereof;

FIG. 4 is a rear elevation view of the boat seat depicted in FIGS. 1-3;

FIG. 5 is a top plan view of the boat seat depicted in FIG. 1-4;

FIG. 6 is a top front perspective view of the boat seat depicted in FIG. 1-5, but showing the back support swung downwardly to the folded position;

FIG. 7 is a front elevation view of the boat seat depicted in FIG. 6;

FIG. 8 is a left side elevation view of the boat seat depicted in FIG. 6, with the right side elevation being a mirror image thereof;

FIG. 9 is a rear elevation view of the boat seat depicted in FIG. 6; and,

FIG. 10 is a plan view of the boat seat depicted in FIG. 6. Bottom elevation views of the boat seat have not been provided, as the bottom of the seat is not visible during normal operation.

The fragmented crosshatching shown on the seat and the backrest is understood to represent fabric and would be continuous throughout the circumscribed area.

(56) **References Cited**

**U.S. PATENT DOCUMENTS**

- D251,997 S \* 6/1979 Pelly ..... D6/356
- D326,568 S \* 6/1992 Lanius et al. .... D6/356
- D449,458 S \* 10/2001 Malmanger et al. .... D6/368

\* cited by examiner

*Primary Examiner*—Mimosa De  
(74) *Attorney, Agent, or Firm*—Hovey Williams LLP

(57) **CLAIM**

The ornamental design for a boat seat, as shown and described.

**1 Claim, 4 Drawing Sheets**

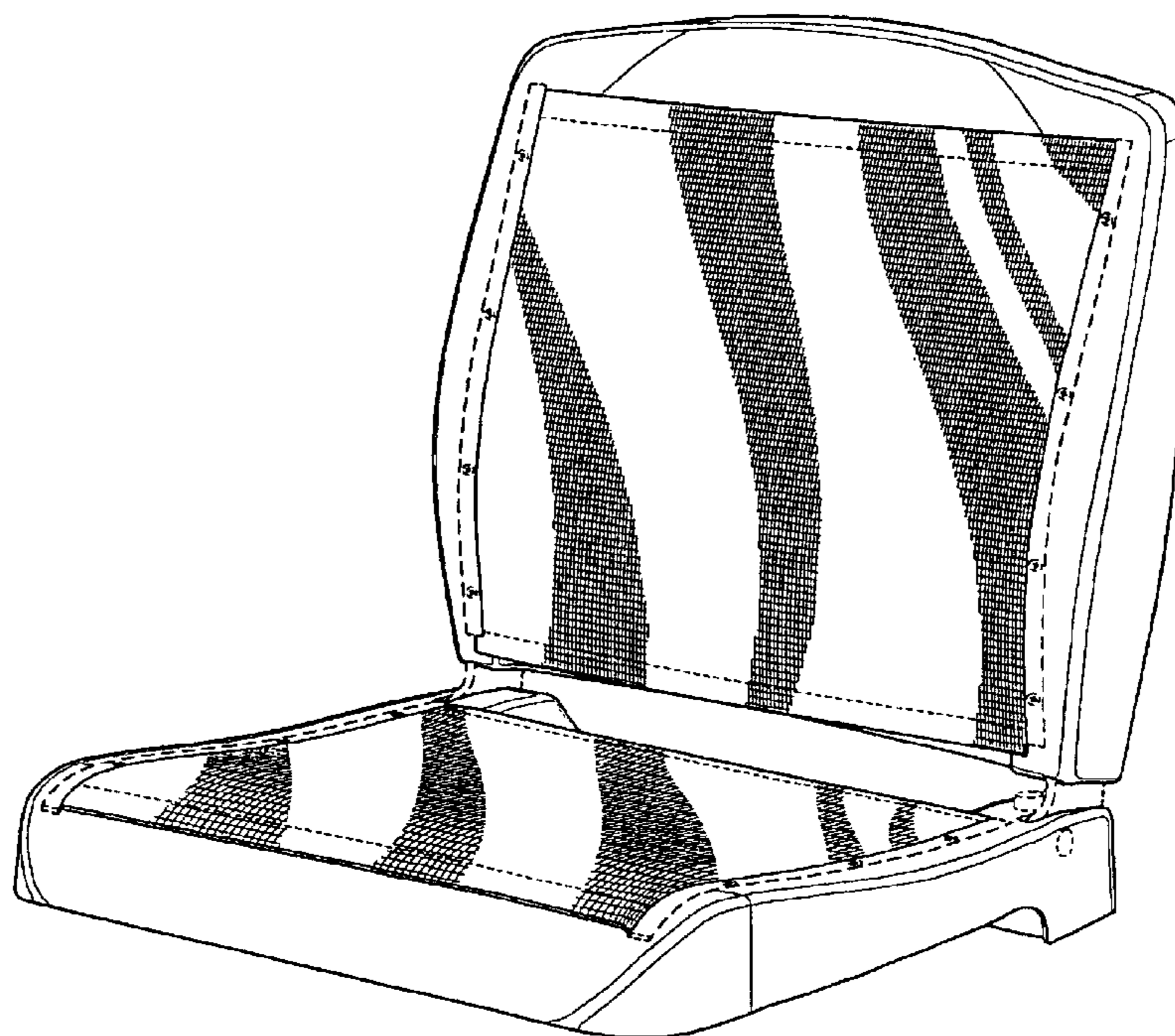

FIG. 1

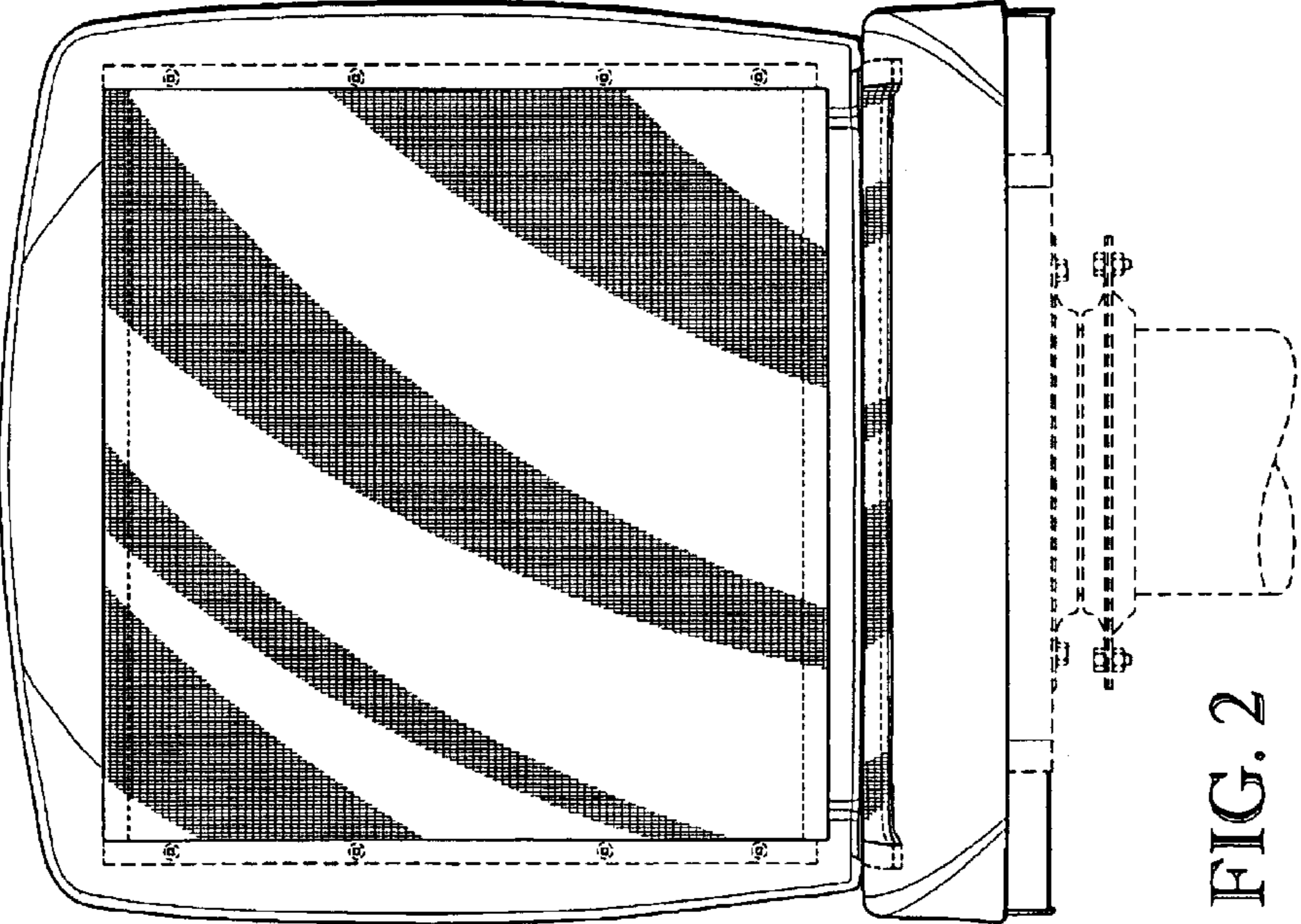
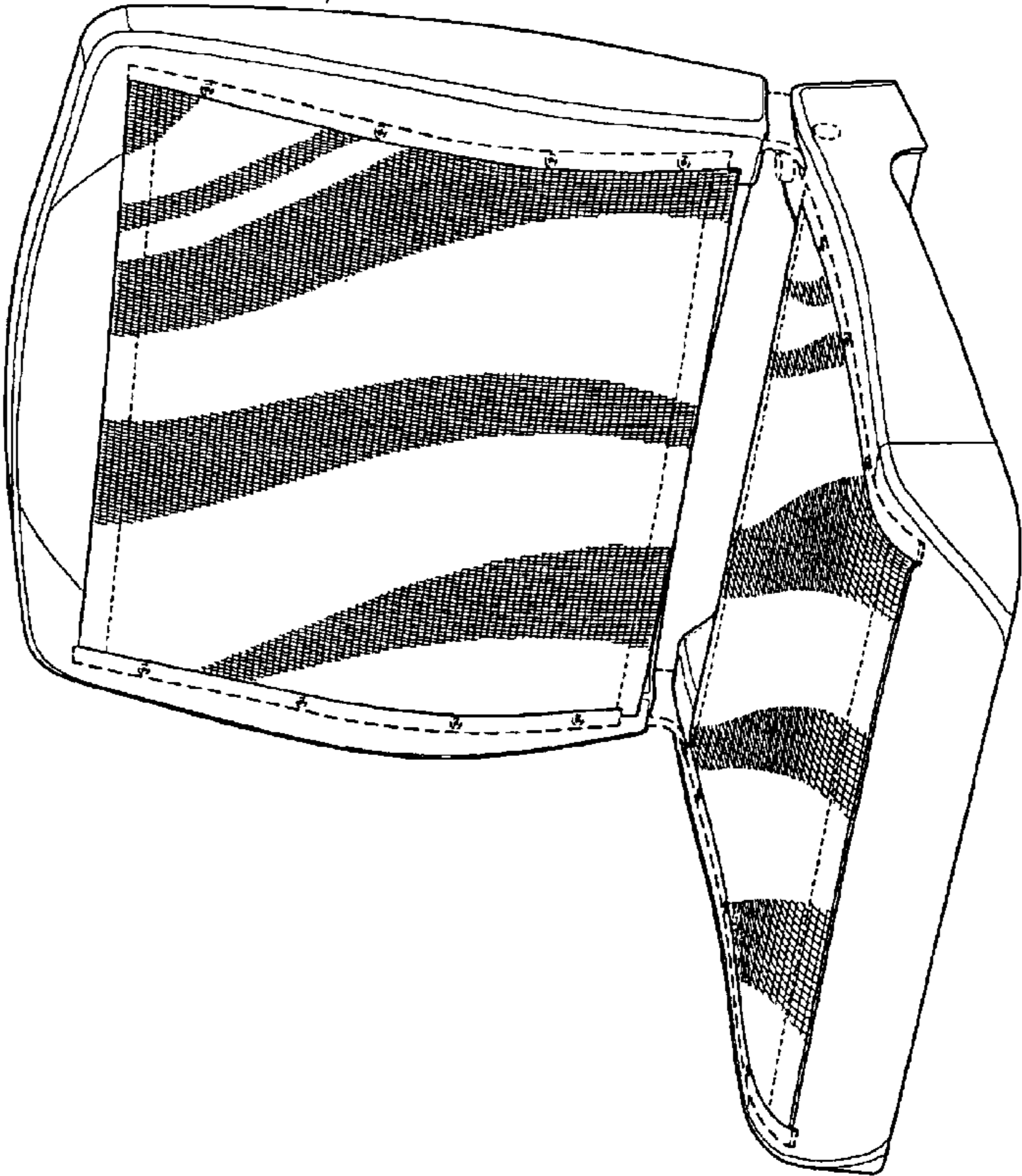

FIG. 2

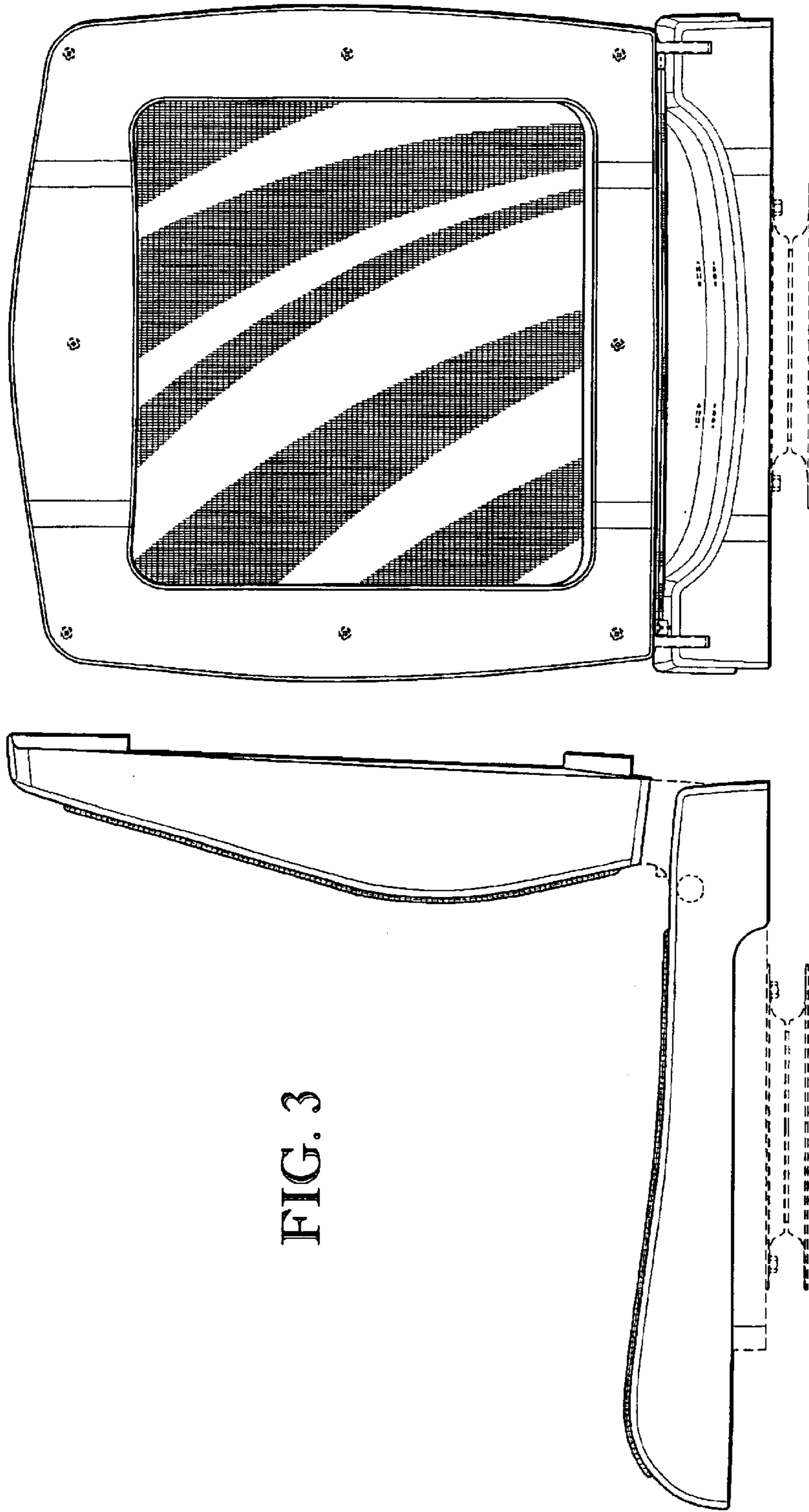

FIG. 3

FIG. 4

FIG. 10

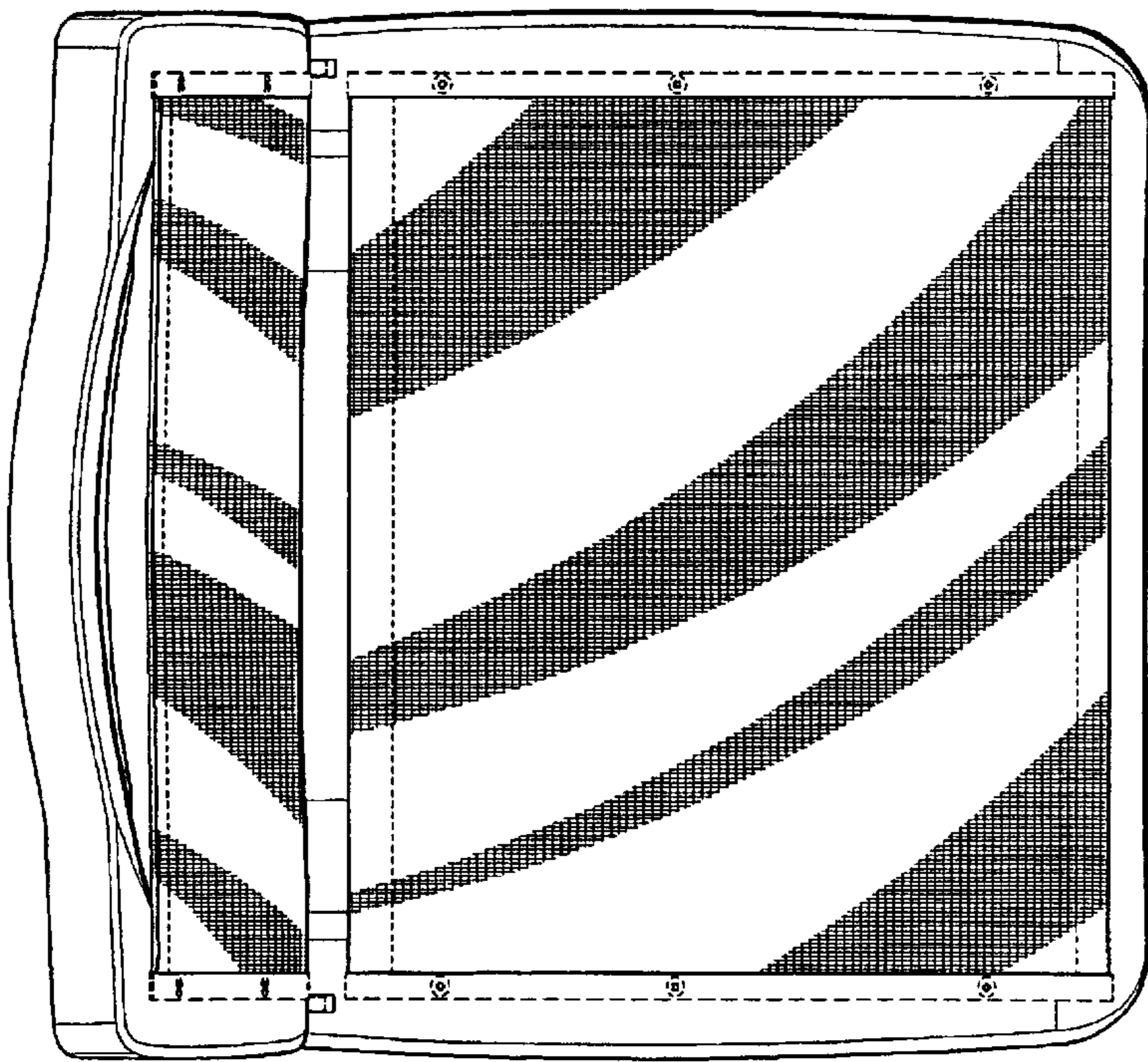
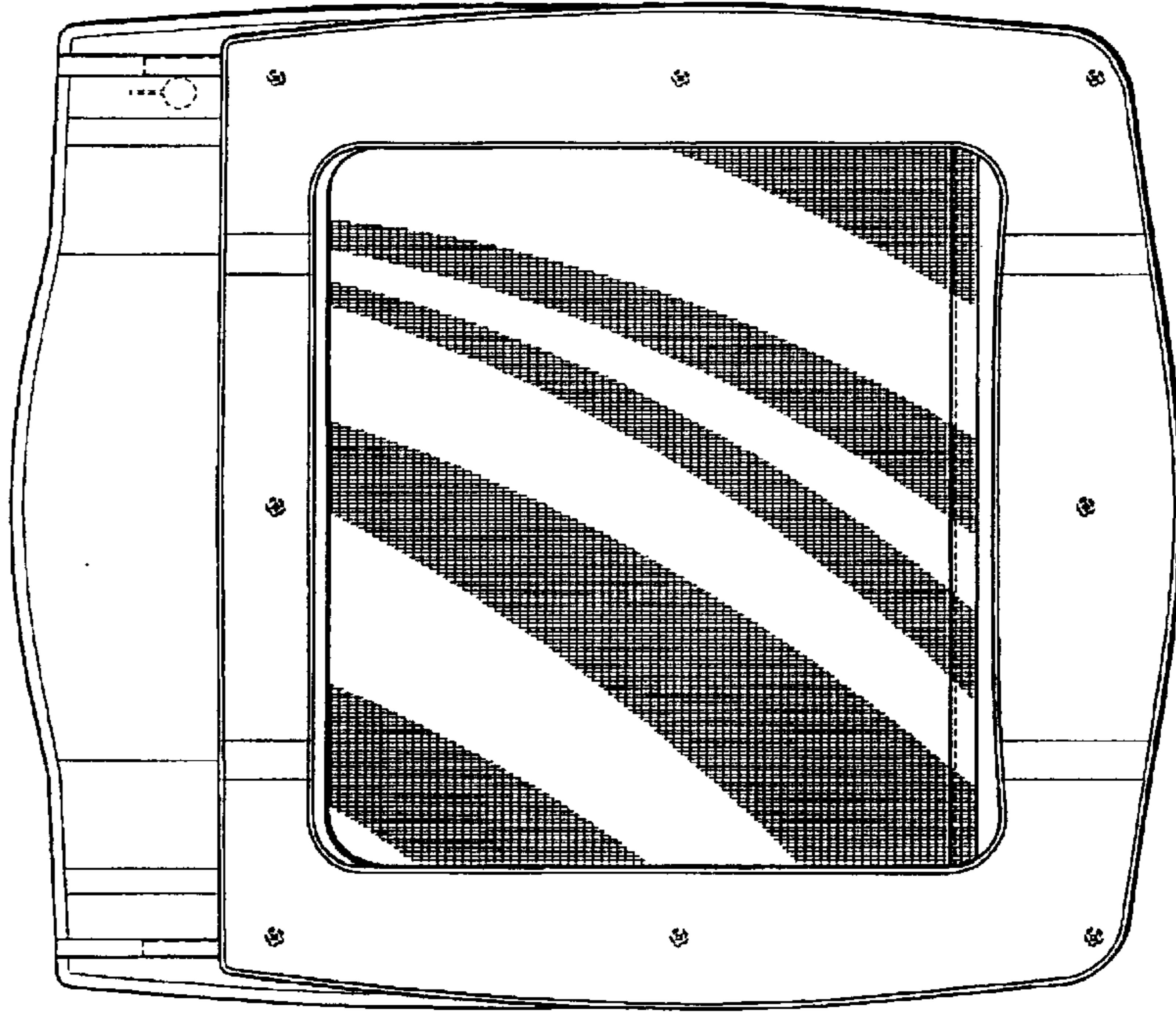

FIG. 5

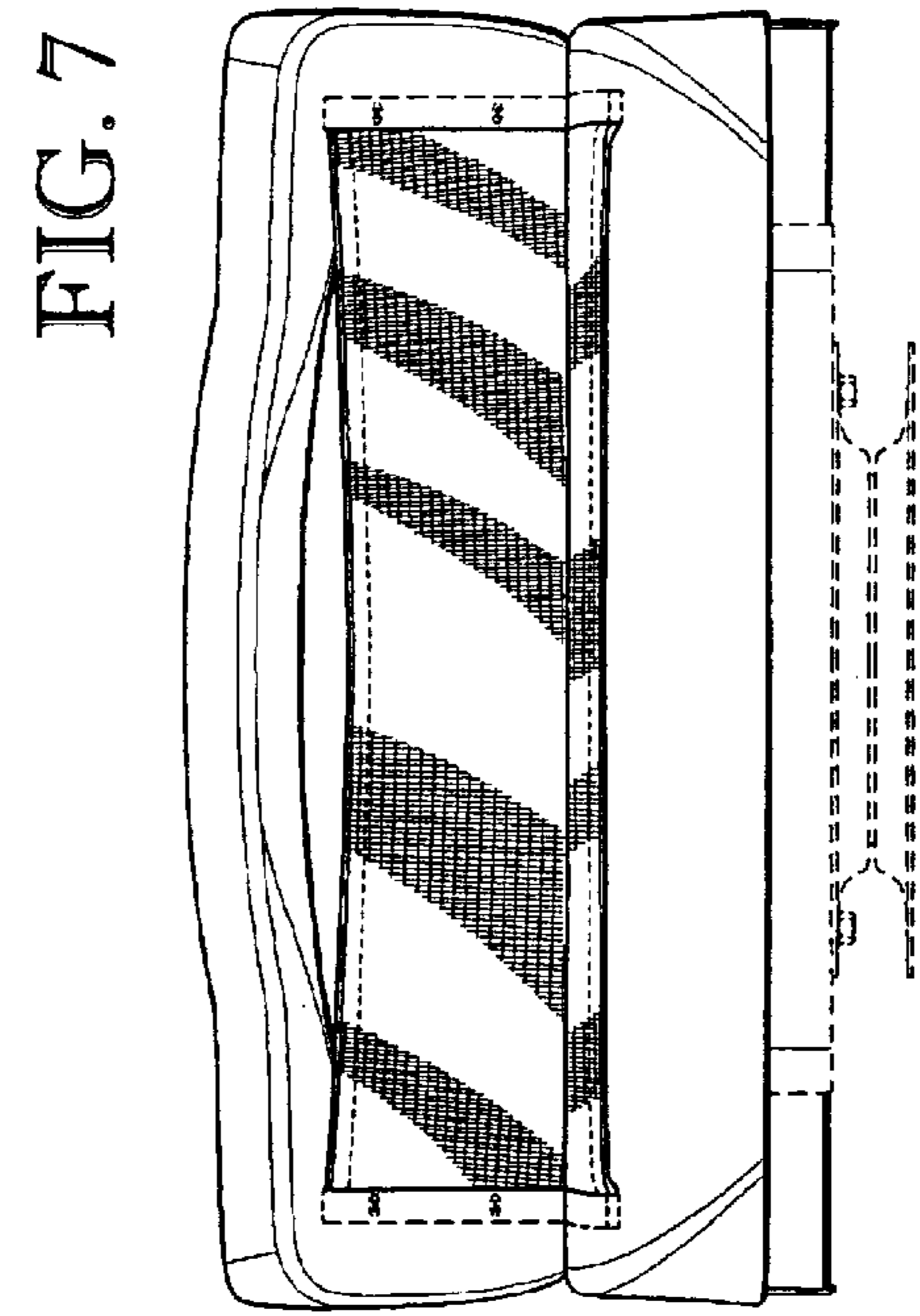

FIG. 7

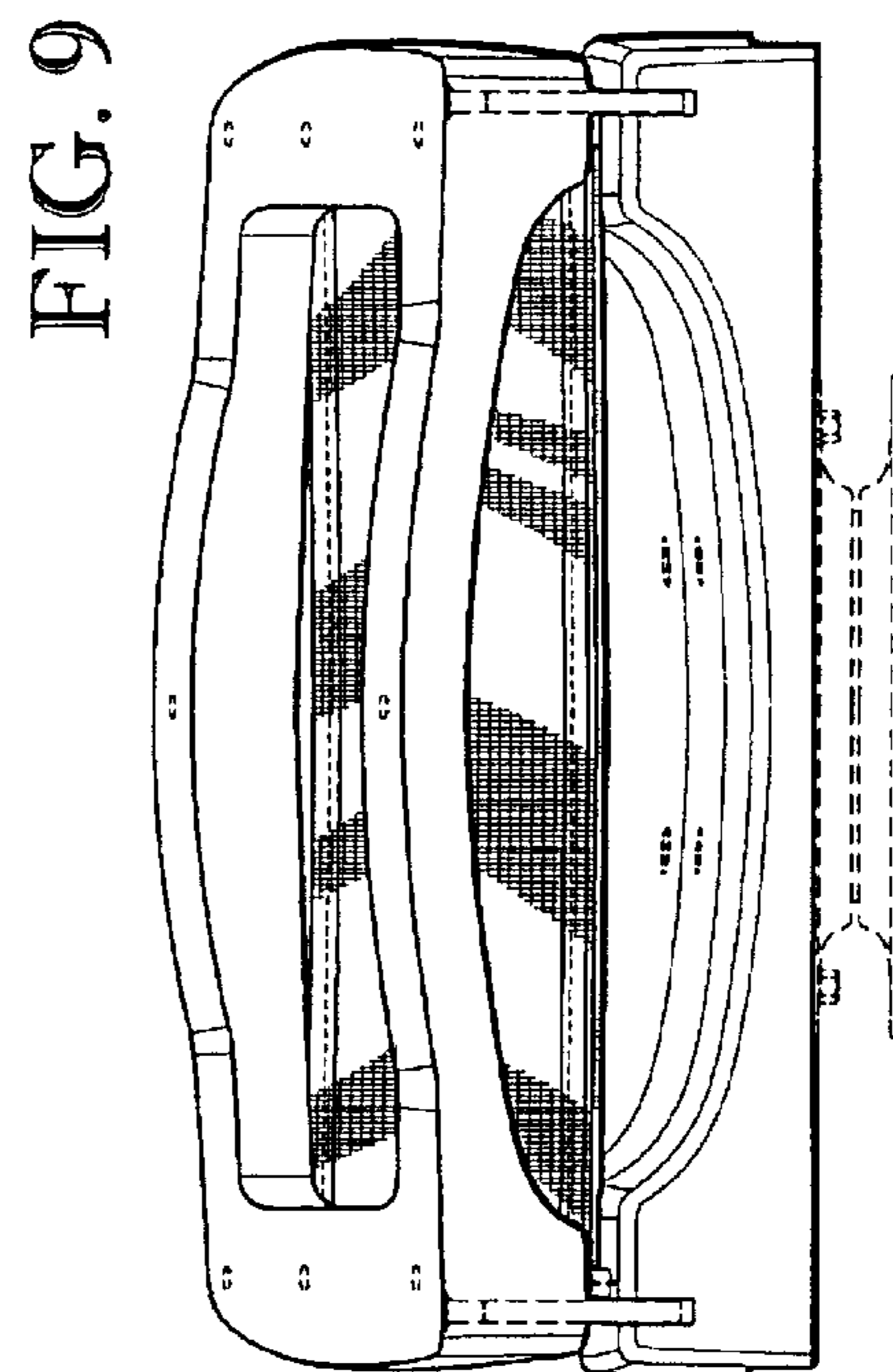

FIG. 9

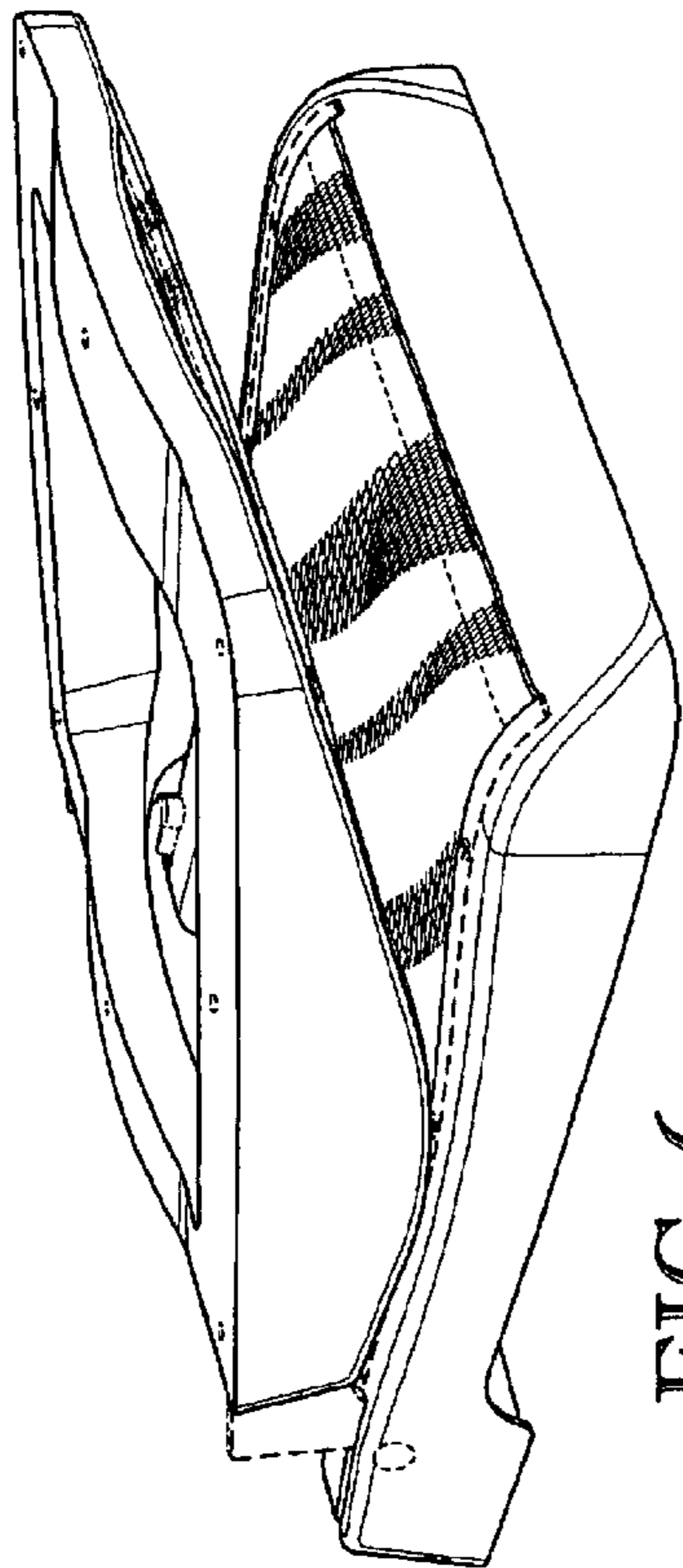

FIG. 6

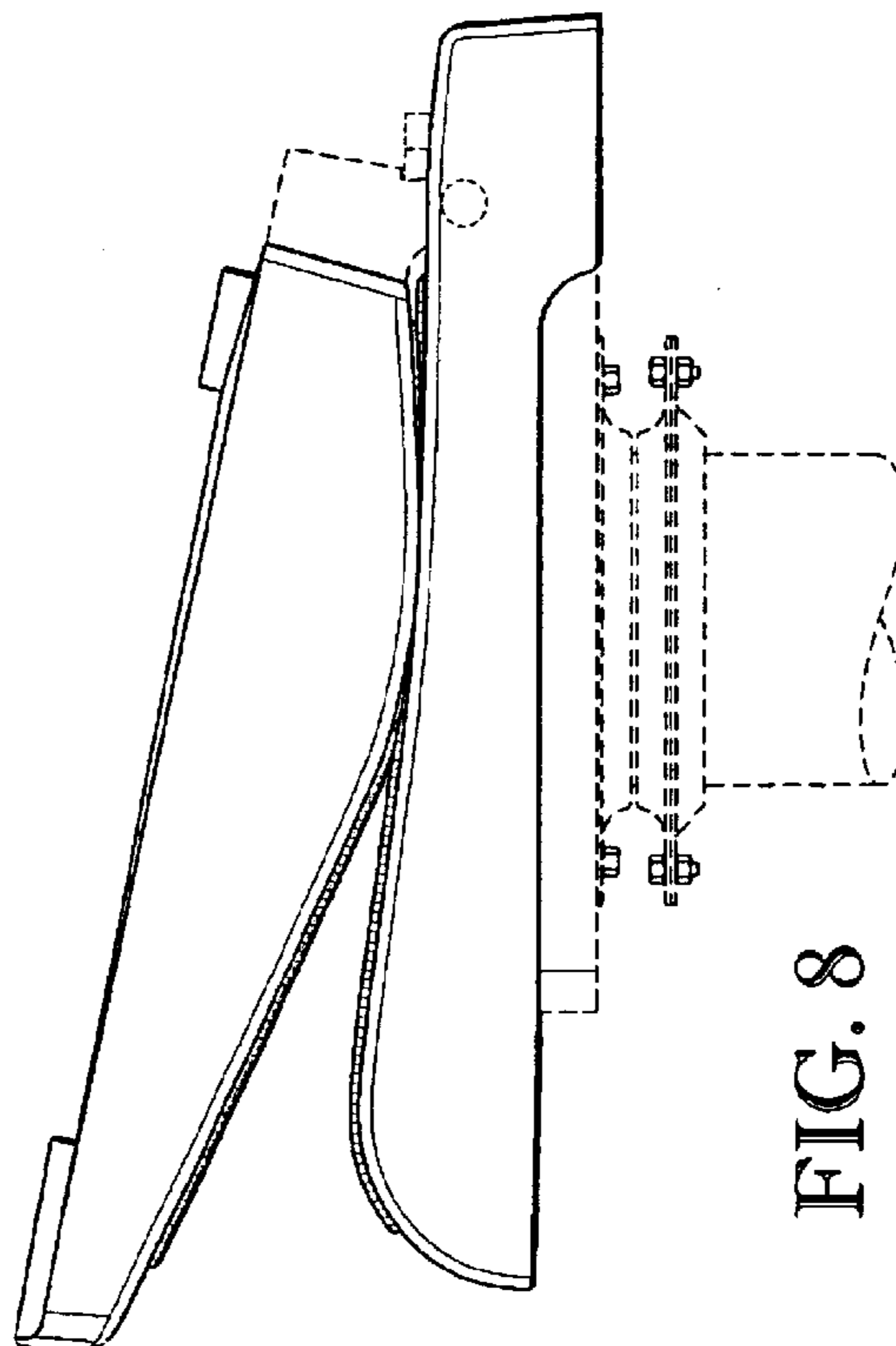

FIG. 8