

US00D502757S

(12) **United States Design Patent**
Mork et al.

(10) **Patent No.: US D502,757 S**
(45) **Date of Patent: ** Mar. 8, 2005**

(54) **WATER TREATMENT SYSTEM**
(75) **Inventors: Steve O. Mork, Lowell, MI (US); Rick G. Good, Rockford, MI (US); Thomas A. Niezgoda, Kentwood, MI (US); Karen J. VanderKooi, Grand Rapids, MI (US)**

D477,050 S * 7/2003 Goodwin D23/209
D481,442 S * 10/2003 Liu D23/209
6,645,376 B2 * 11/2003 Marioni 210/169
D487,914 S * 3/2004 Schulze et al. D23/209

* cited by examiner

Primary Examiner—Robin V. Taylor
(74) *Attorney, Agent, or Firm*—Alticor Inc.

(73) **Assignee: Access Business Group International LLC, Ada, MI (US)**

(57) **CLAIM**

(**) **Term: 14 Years**

The ornamental design for the water treatment system, as shown and described.

(21) **Appl. No.: 29/191,934**

DESCRIPTION

(22) **Filed: Oct. 16, 2003**

FIG. 1 is an isometric view of the water treatment system;
FIG. 2 is a front view thereof;
FIG. 3 is a left side view thereof;
FIG. 4 is a rear view thereof;
FIG. 5 is a right side view thereof;
FIG. 6 is a top view thereof; and,
FIG. 7. is a bottom view thereof.

(51) **LOC (7) Cl. 23-01**

(52) **U.S. Cl. D23/207**

(58) **Field of Search D23/207, 209;
210/232, 443, 444, 238, 341**

(56) **References Cited**

U.S. PATENT DOCUMENTS

D320,640 S * 10/1991 Goodwin D23/209

1 Claim, 7 Drawing Sheets

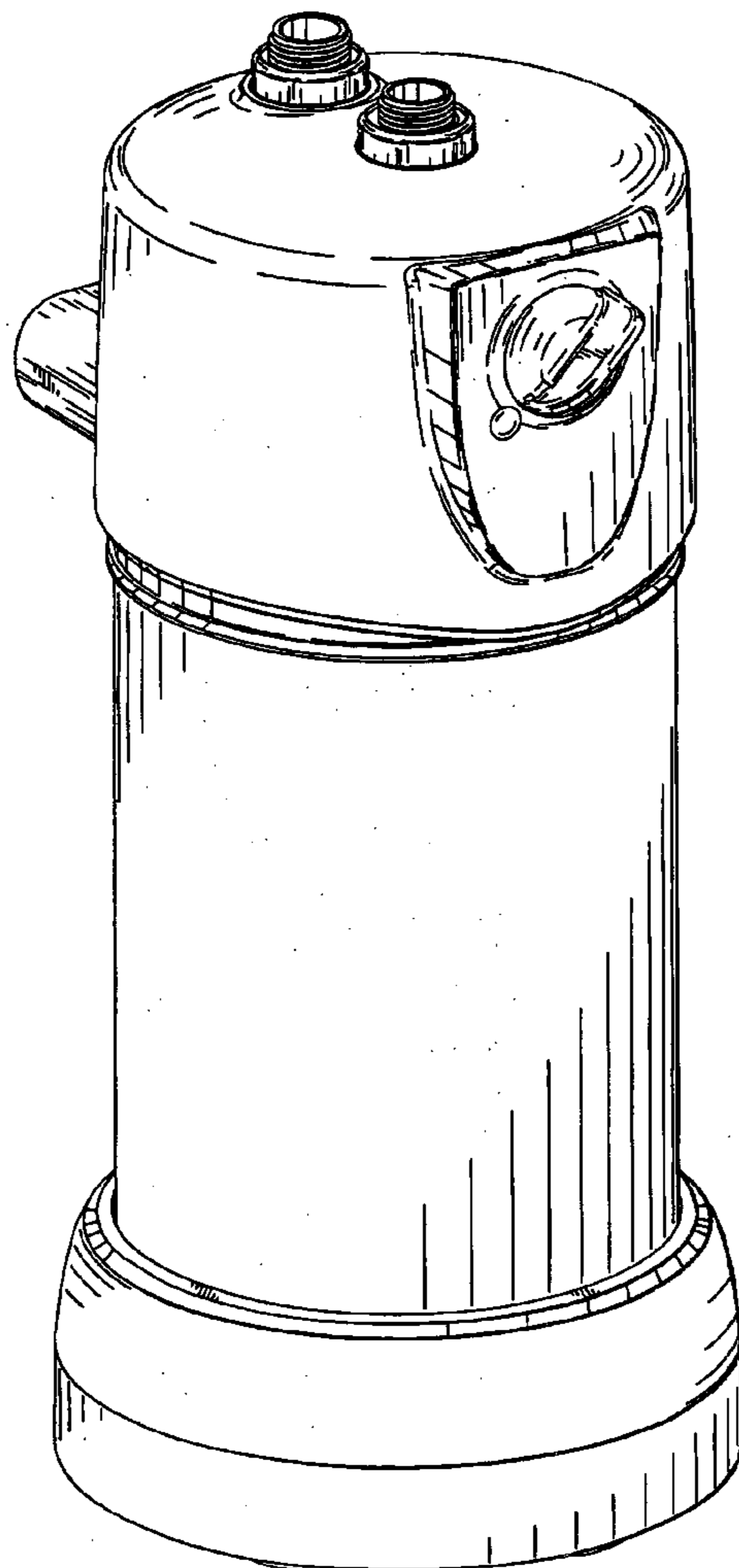

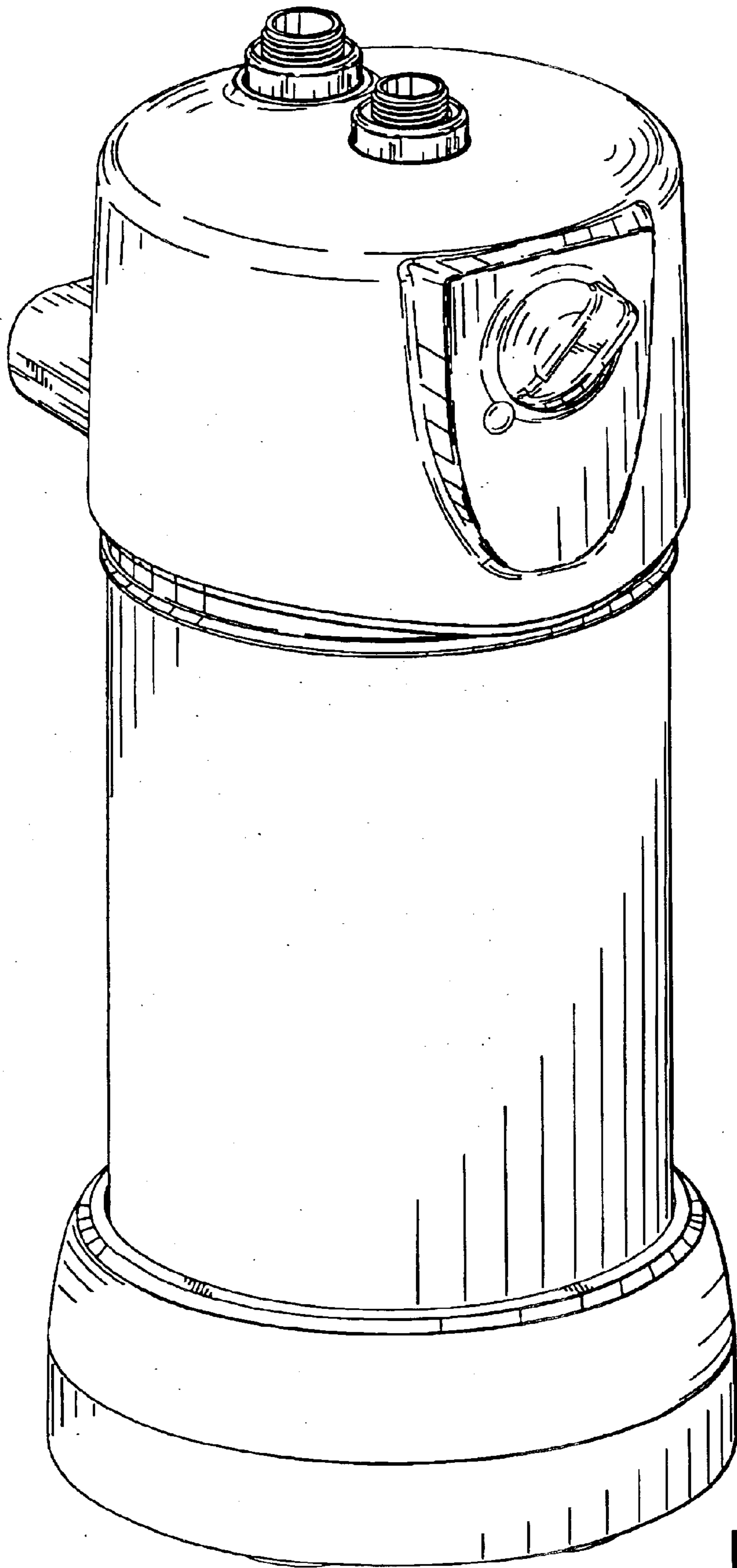

FIG. 1

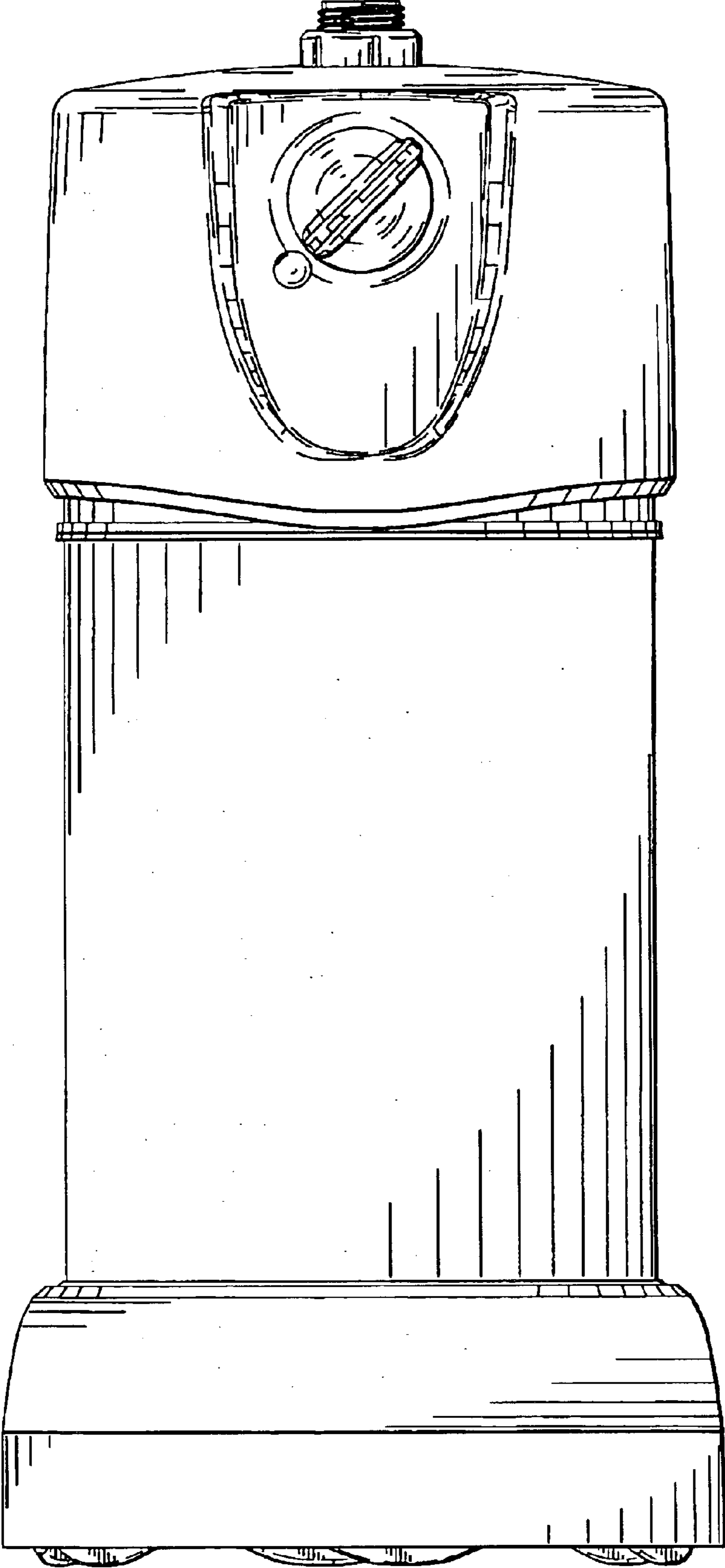

FIG. 2

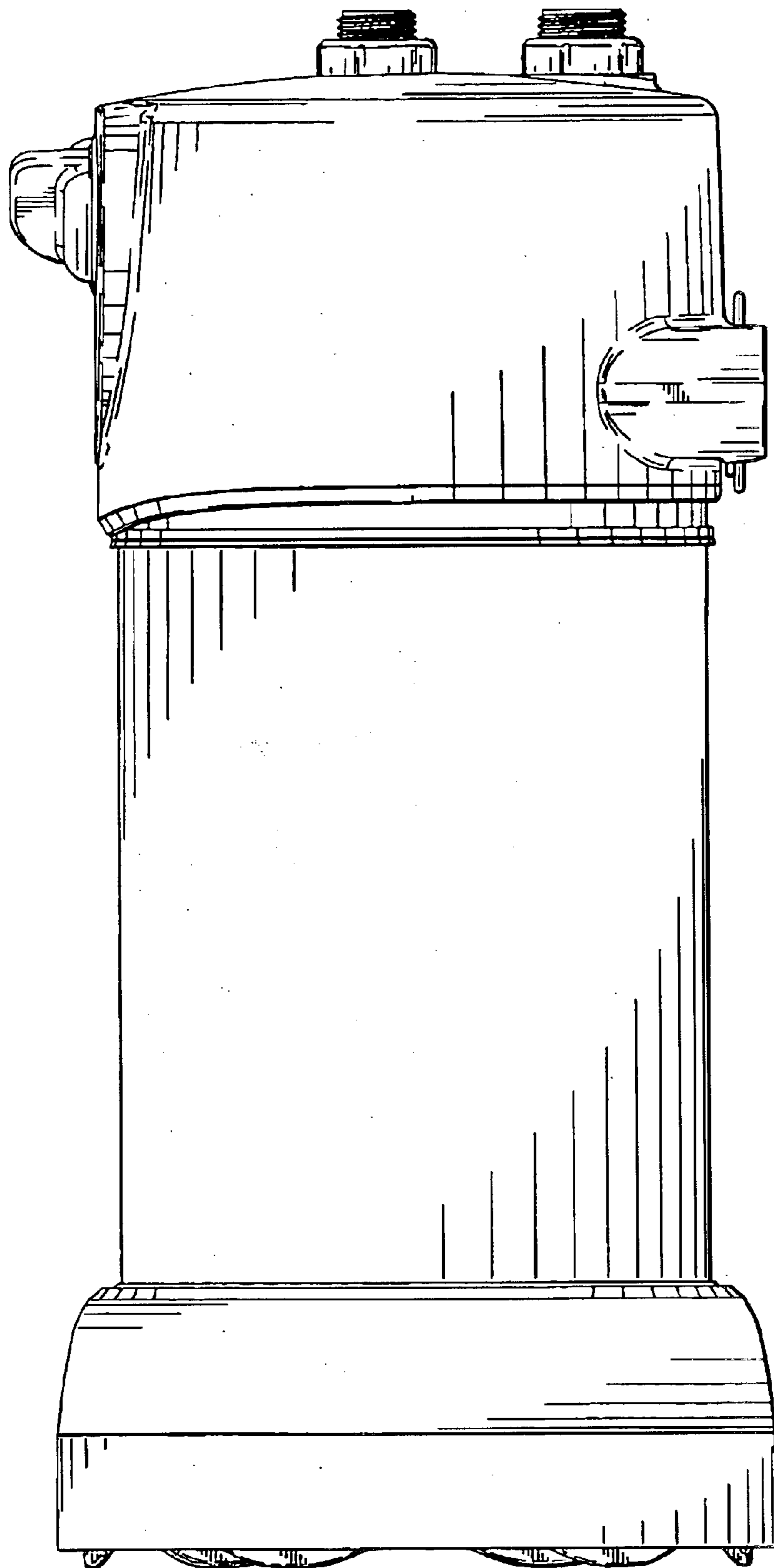

FIG. 3

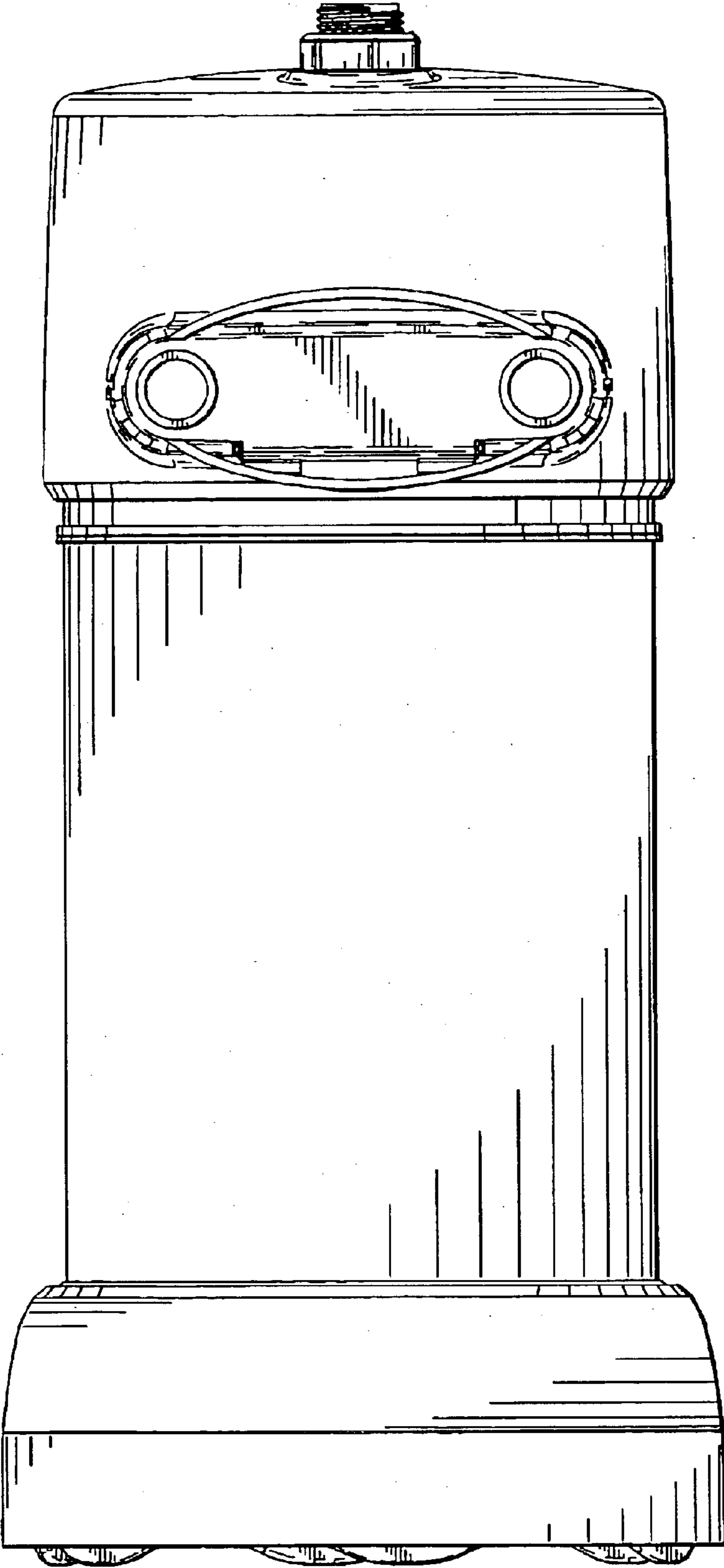

FIG. 4

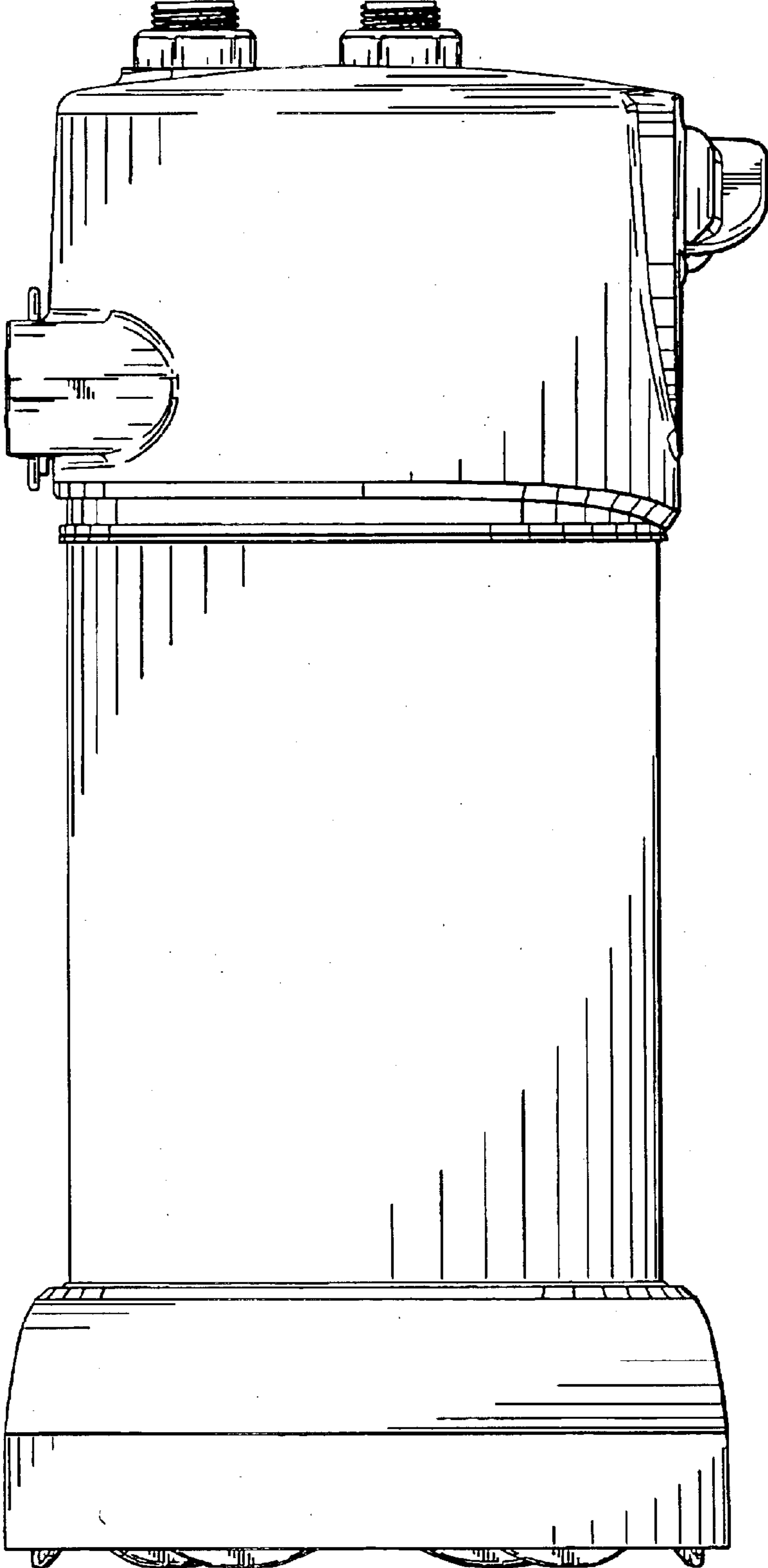

FIG. 5

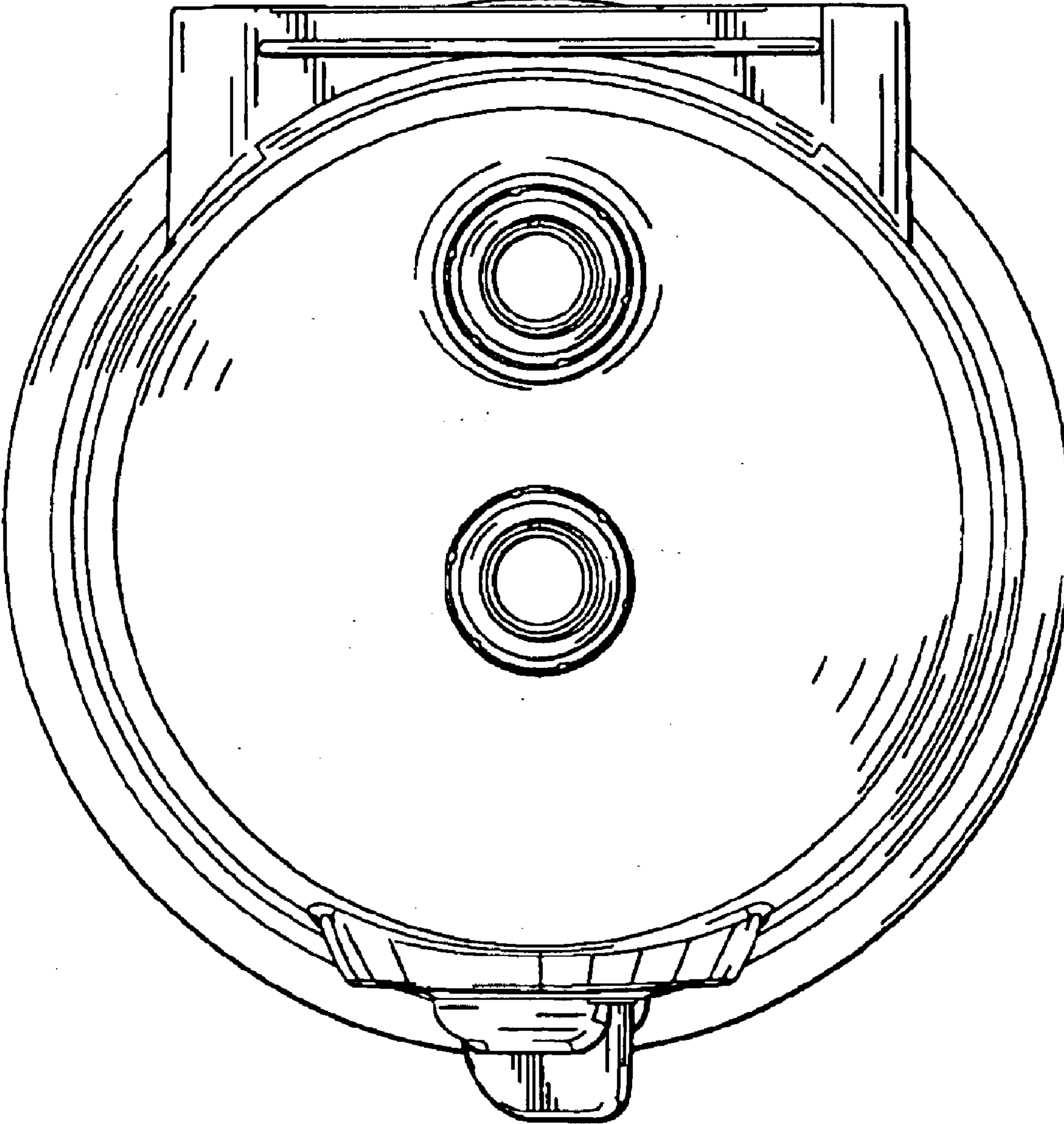

FIG. 6

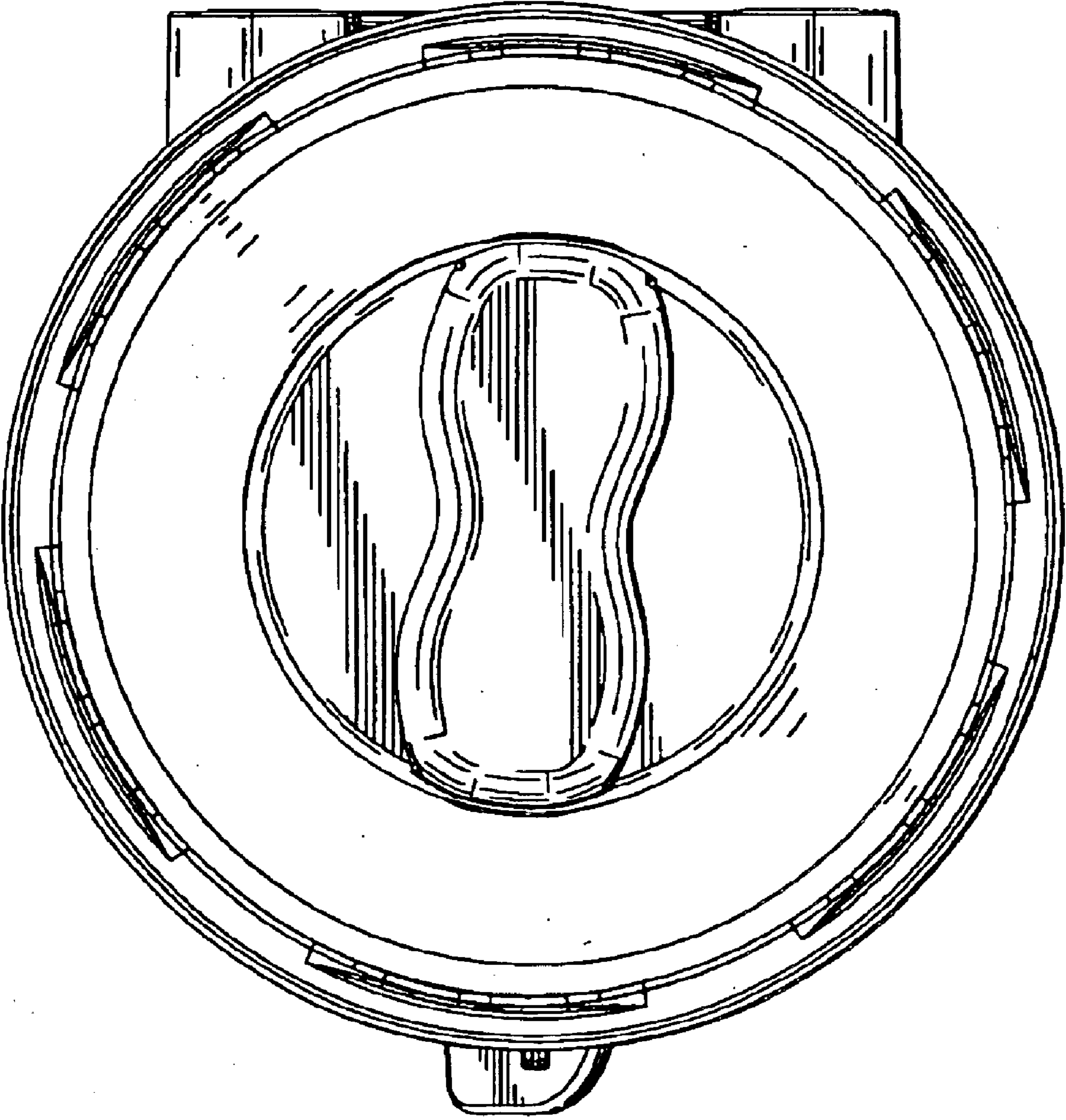

FIG. 7