

US00D502440S

(12) **United States Design Patent** (10) **Patent No.:** **US D502,440 S**
MacWilliam et al. (45) **Date of Patent:** **** Mar. 1, 2005**

(54) **OVERHEAD CONSOLE FOR A SPORT UTILITY VEHICLE**

6,338,517 B1 1/2002 Canni
D473,841 S * 4/2003 Kendrick, III D12/418

(75) Inventors: **Roderick J. MacWilliam**, Arvada, CO (US); **Frank A. Borke**, Windsor, CO (US)

(73) Assignee: **Bestop, Inc.**, Broomfield, CO (US)

(**) Term: **14 Years**

(21) Appl. No.: **29/193,035**

(22) Filed: **Oct. 31, 2003**

(51) **LOC (7) Cl.** **12-16**

(52) **U.S. Cl.** **D12/418**

(58) **Field of Search** D12/415, 418, D12/400; D14/124, 126, 129, 113, 132-133, 100; 296/37.1-37.8, 70; 224/311, 539; 180/90; 439/34

(56) **References Cited**

U.S. PATENT DOCUMENTS

4,538,752 A	9/1985	Welter	
D282,733 S	* 2/1986	Giavazzi et al. D12/418
4,650,238 A	3/1987	Healey	
D297,527 S	* 9/1988	Iacovelli D12/418
D297,826 S	* 9/1988	Cody D12/418
D315,704 S	* 3/1991	Eyrich D12/418
D320,587 S	* 10/1991	Kapp et al. D12/418
D339,780 S	* 9/1993	Burdick D12/418
D340,016 S	* 10/1993	Falcoff D12/418
D340,017 S	* 10/1993	Falcoff D12/418
D340,215 S	* 10/1993	Falcoff D12/418
5,303,970 A	4/1994	Young	
D411,822 S	* 7/1999	Ellis D12/418
D413,856 S	* 9/1999	Scribner D12/418
6,024,262 A	2/2000	Duncan	
D428,849 S	* 8/2000	Higginson D12/418
D434,718 S	12/2000	Kreisler	

OTHER PUBLICATIONS

Overhead Security Console, [online], [retrieved Oct. 5, 2004], Retrieved from Tuffy Security Products using Internet < URL:http://www.tuffyproducts.com/consoles/overhead/048.html>.

Overhead Security Console, [online], [retrieved Oct. 5, 2004], Retrieved form Tuffy Security Products using Internet<URL:http://www.tuffyproducts.com/consoles/overhead/103.html>.

* cited by examiner

Primary Examiner—Stacia Cadmus

(74) *Attorney, Agent, or Firm*—W. Scott Carson

(57) **CLAIM**

The ornamental design for an overhead console for a sport utility vehicle, as shown and described.

DESCRIPTION

FIG. 1 is a perspective view of a sport utility vehicle with an overhead console for a sport utility vehicle mounted thereon showing our new design. The broken lines showing the vehicle are for illustrative purposes only and form no part of our design.

FIG. 2 is a perspective view thereof.

FIG. 3 is a bottom plan view thereof.

FIG. 4 is a left side elevational view thereof, the right side elevational view being symmetrical.

FIG. 5 is a rear elevational view thereof.

FIG. 6 is a front elevational view thereof; and,

FIG. 7 is a top plan view thereof.

FIGS. 2-7 are shown on an enlarged scale as compared to FIG. 1.

1 Claim, 6 Drawing Sheets

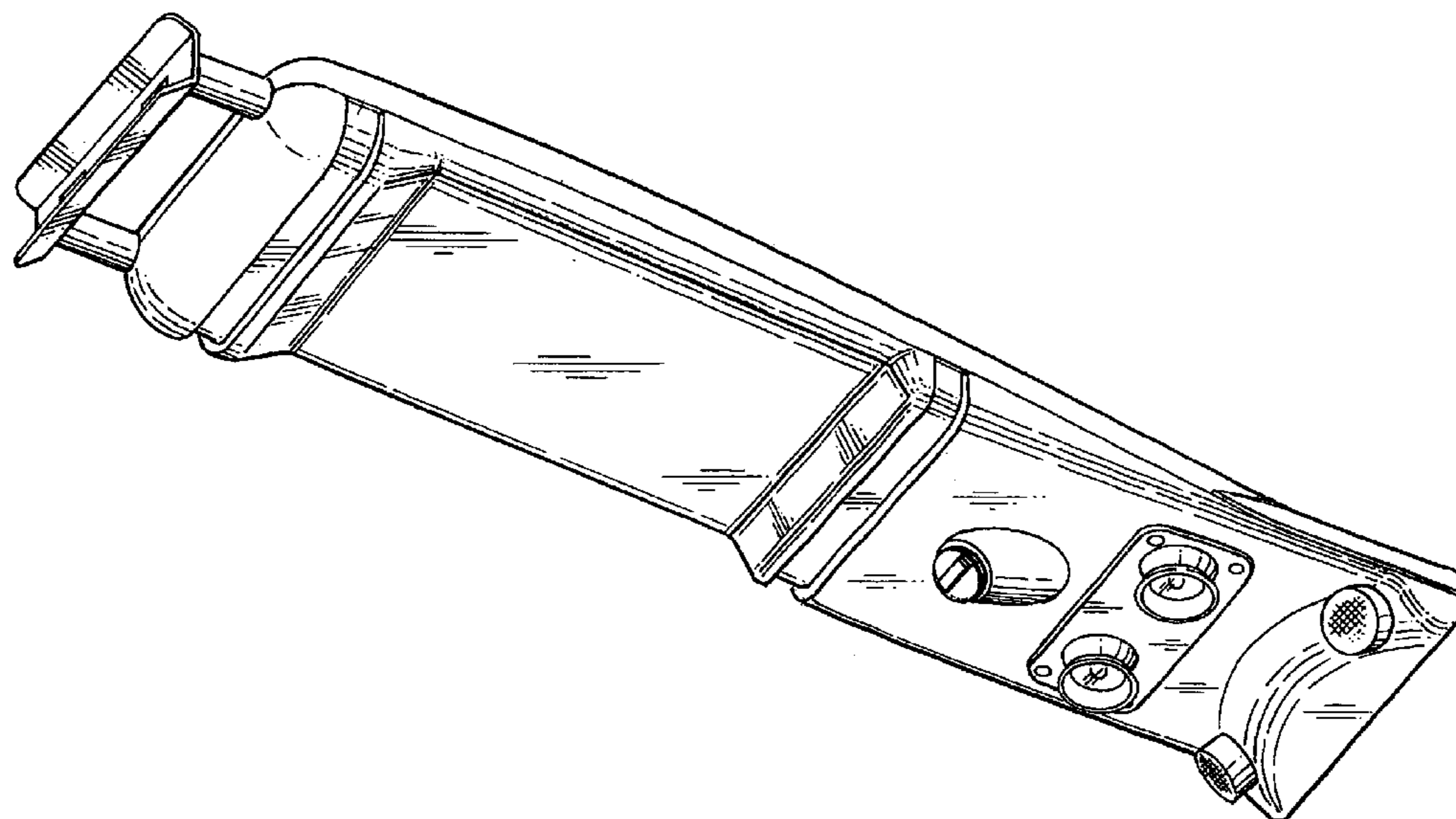
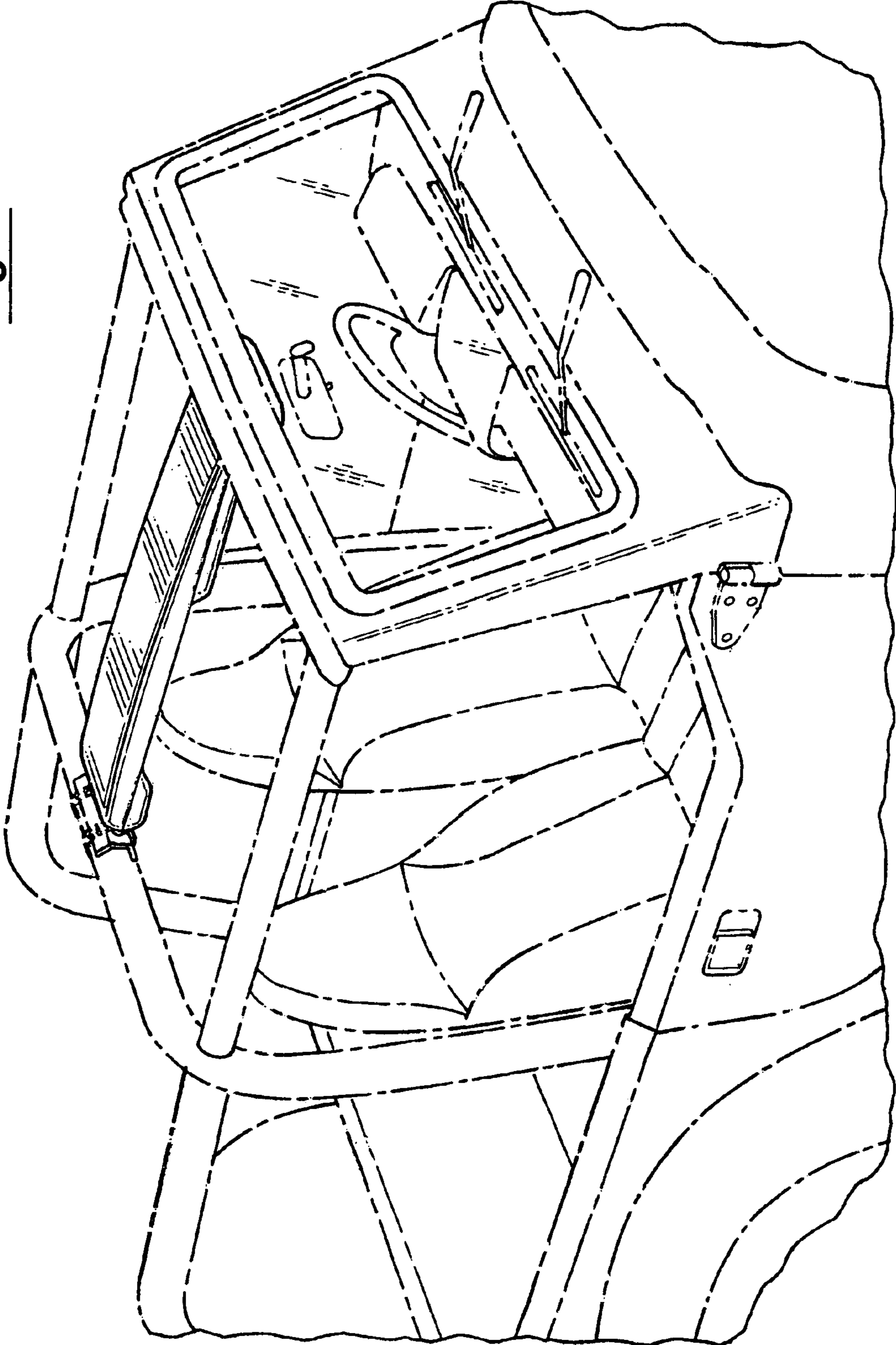

Fig. 1



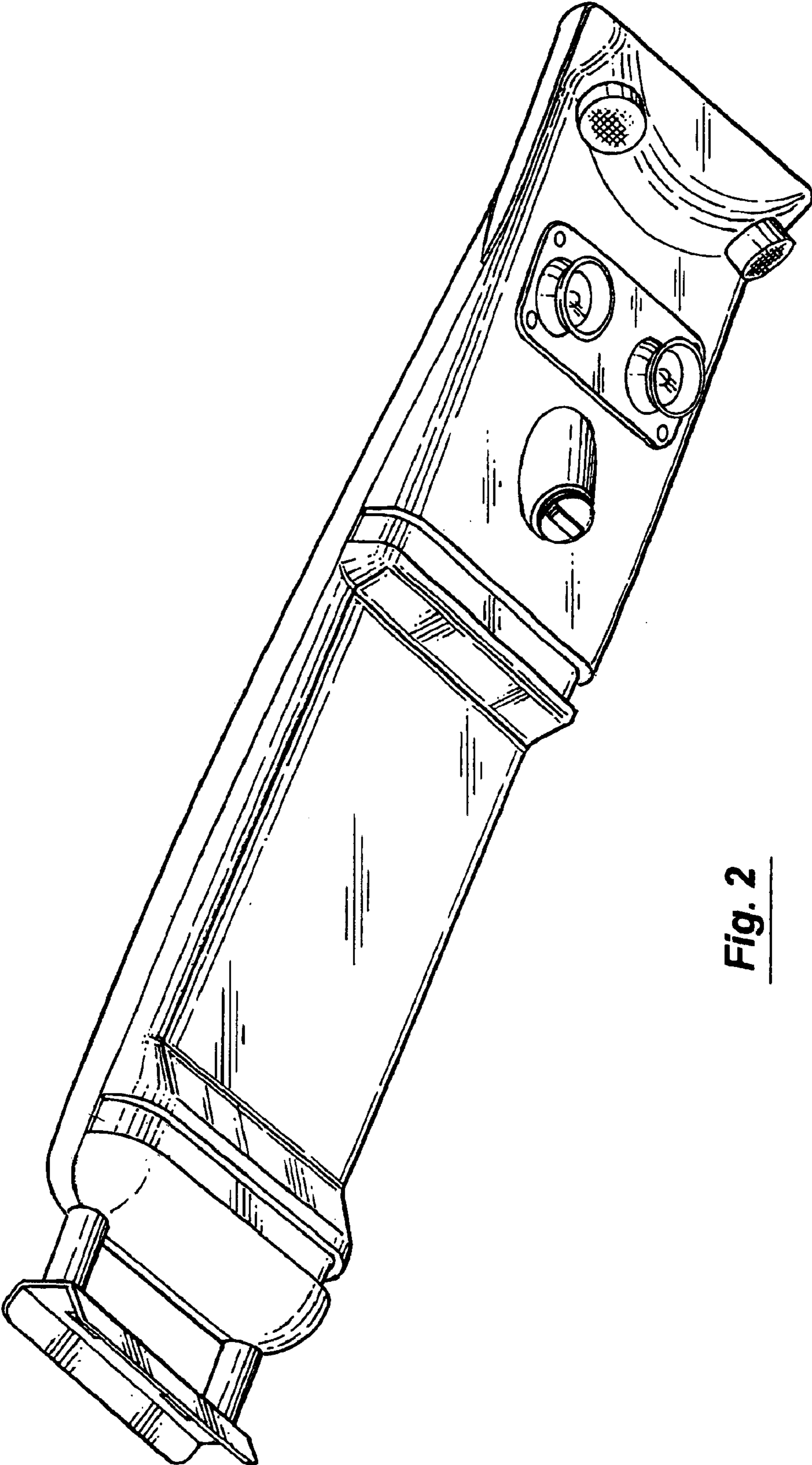

Fig. 2

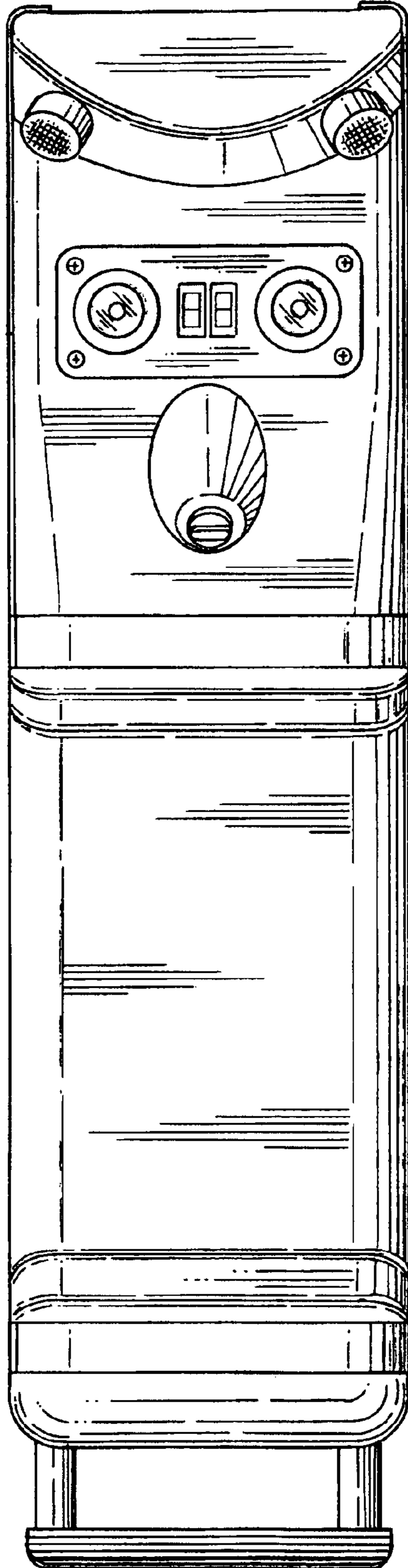

Fig. 3

Fig. 4

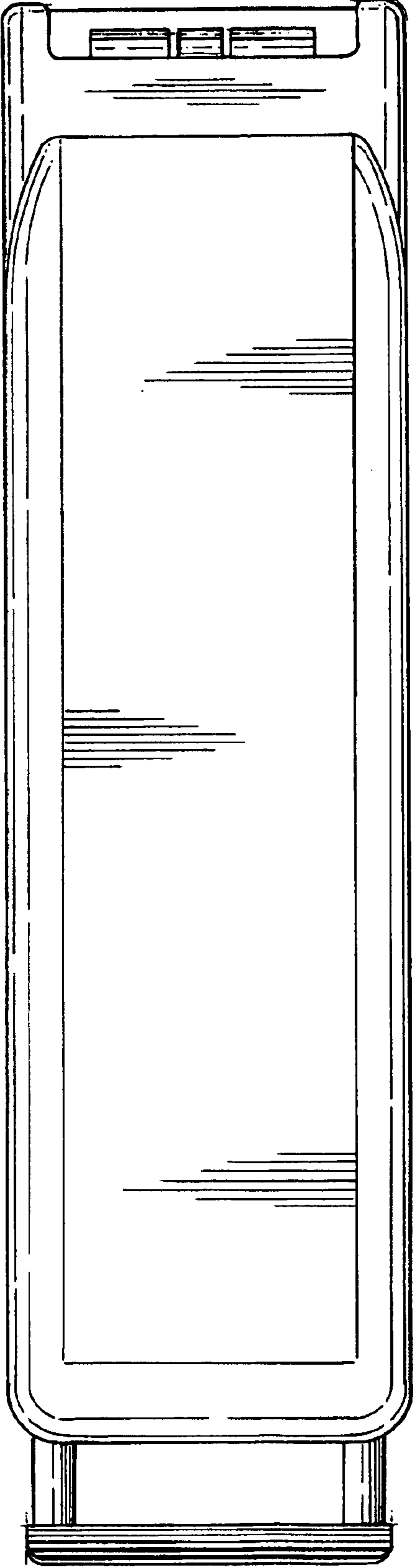
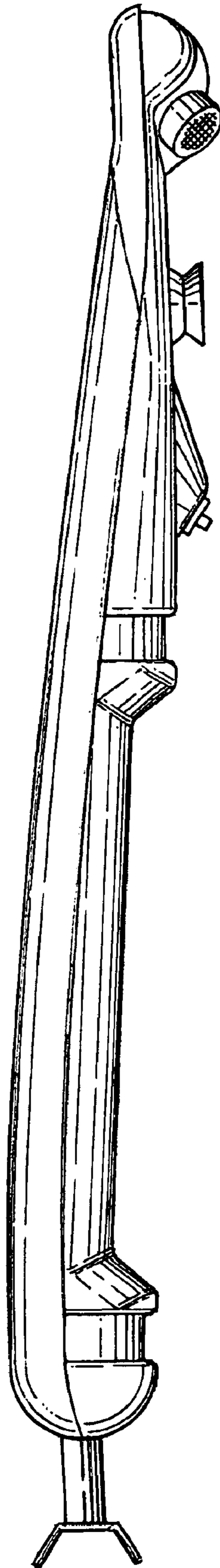

Fig. 5



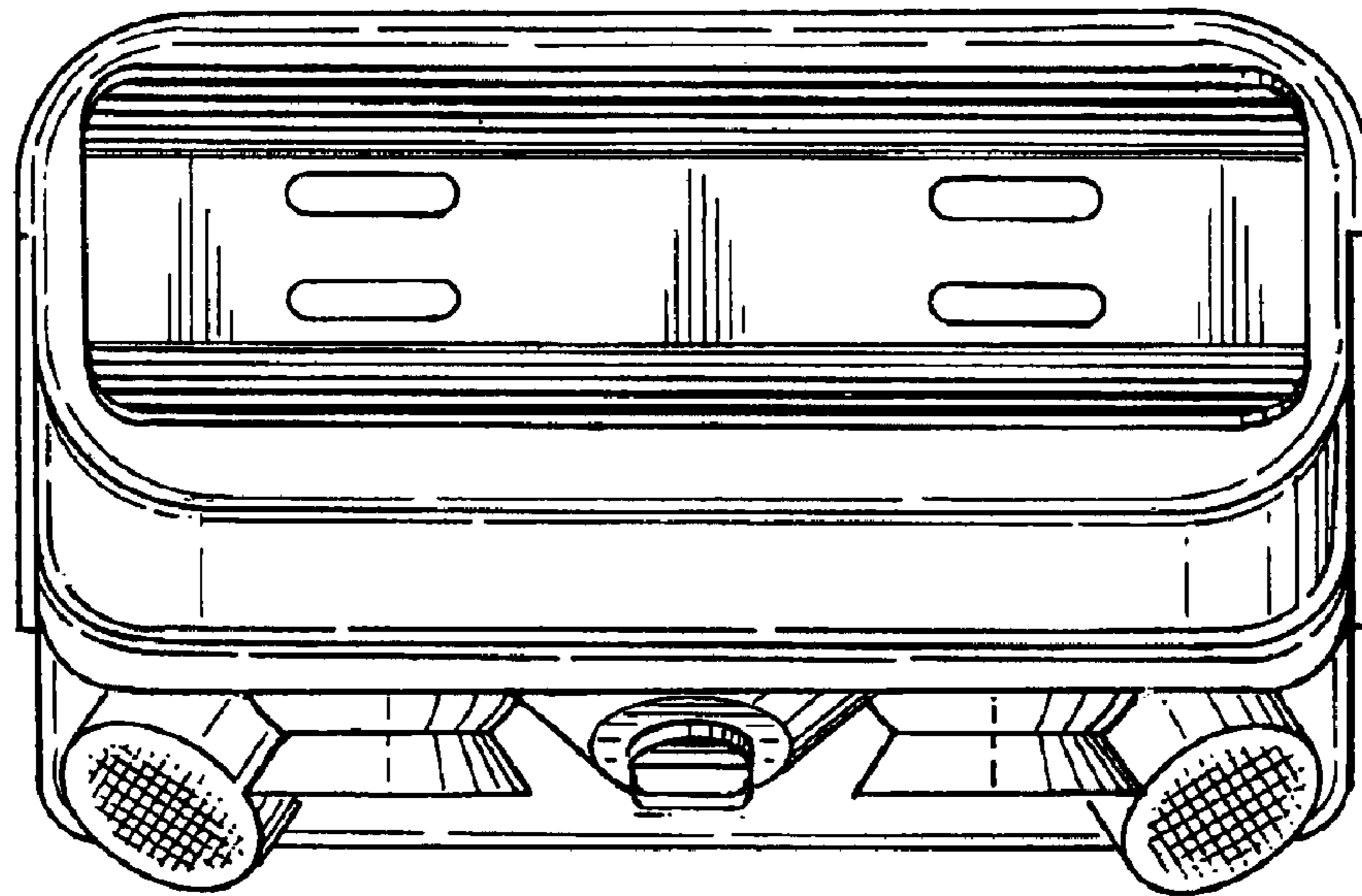

Fig. 6

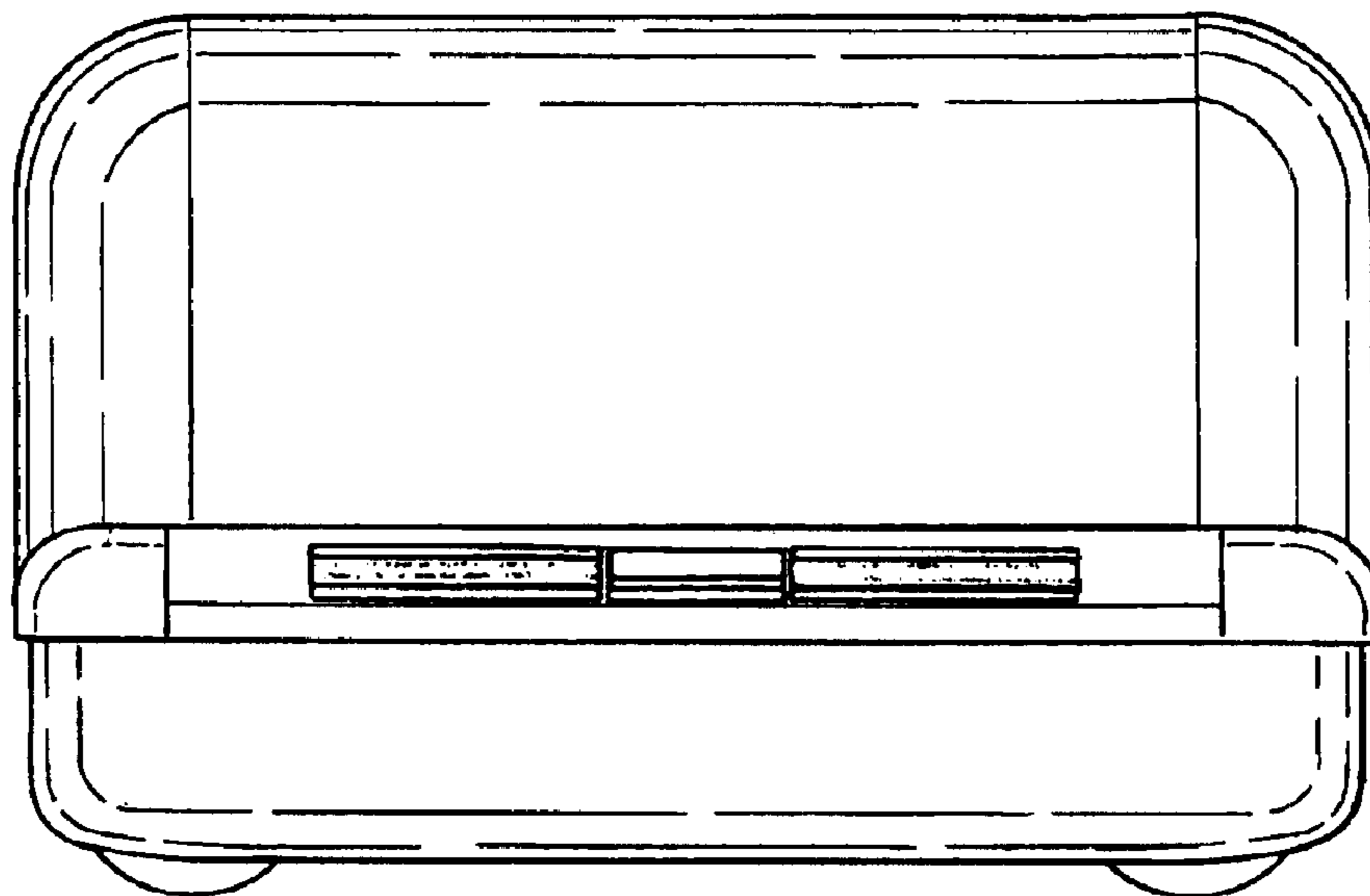

Fig. 7