

US00D502139S

(12) **United States Design Patent** (10) **Patent No.:** **US D502,139 S**  
**Chrisco et al.** (45) **Date of Patent:** **\*\* Feb. 22, 2005**

(54) **COMBINATION TANDEM AXLE WHEEL  
 CHOCK AND TRAILER TONGUE STAND**

(75) Inventors: **Larry L. Chrisco**, Fairland, OK (US);  
**Charlie L. Forbis**, Quapaw, OK (US)

(73) Assignee: **Blita U.S.A., Inc.**, Miami, OK (US)

(\*\*) Term: **14 Years**

(21) Appl. No.: **29/209,458**

(22) Filed: **Jul. 16, 2004**

(51) **LOC (7) Cl.** ..... **12-06**

(52) **U.S. Cl.** ..... **D12/217**

(58) **Field of Search** ..... D12/217, 400,  
 D12/120, 203; D8/402; D34/27; 280/293;  
 188/32, 36, 4 R; 410/30, 49; 267/139-140

(56) **References Cited**

**U.S. PATENT DOCUMENTS**

1,893,580 A	1/1933	Colley	
2,613,764 A	11/1952	Worden	
D181,031 S	9/1957	Wilson et al.	
2,954,101 A	* 9/1960	Corson	188/32
D210,304 S	* 2/1968	Davis	D12/217
D215,325 S	9/1969	Merto	
D229,330 S	11/1973	Miles	
D236,612 S	9/1975	Wetzel et al.	
D282,459 S	* 2/1986	Sauber	D12/217
D298,823 S	* 12/1988	Zutler	D12/217
4,797,024 A	1/1989	Forrer	
D307,575 S	5/1990	Gano	
D316,243 S	4/1991	Henry	
5,046,587 A	9/1991	Jones	
D321,498 S	11/1991	Jones	
D326,254 S	* 5/1992	Ziaylek et al.	D12/217
5,332,066 A	7/1994	Pickeral	
5,383,639 A	1/1995	Byard	
D365,078 S	* 12/1995	Ziaylek	D12/217

5,687,516 A	11/1997	Sheehan et al.	
D387,323 S	12/1997	Wilcox	
D409,554 S	* 5/1999	Henry	D12/217
D432,976 S	* 10/2000	Chiang	D12/217
D448,338 S	11/2001	Duvall	
D474,729 S	* 5/2003	Sargent	D12/217
D489,310 S	5/2004	Olson et al.	
D493,408 S	* 7/2004	Chrisco et al.	D12/217

\* cited by examiner

*Primary Examiner*—Stacia Cadmus

(74) *Attorney, Agent, or Firm*—Hovey Williams LLP

(57) **CLAIM**

The ornamental design for a combination tandem axle wheel chock and trailer tongue stand, as shown and described.

**DESCRIPTION**

This application is being filed contemporaneously with application for U.S. Letters Patent Ser. No. 10/710,514, entitled Combination Tandem Axle Wheel Chock and Trailer Tongue Stand, which is hereby incorporated by reference herein.

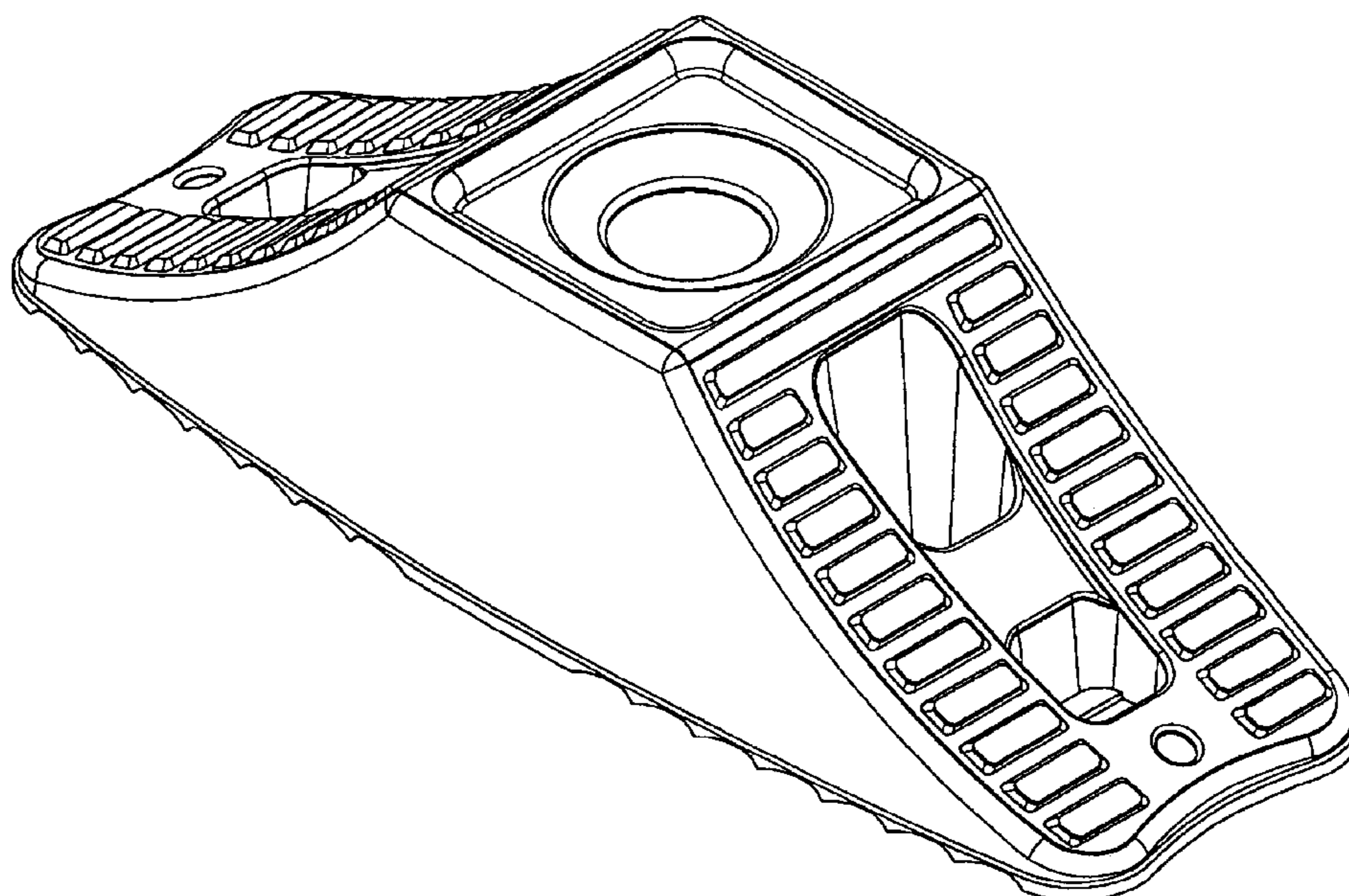
FIG. 1 is a perspective view of an combination tandem axle wheel chock and trailer tongue stand embodying our design; FIG. 2 is a plan view of the combination tandem axle wheel chock and trailer tongue stand depicted in FIG. 1;

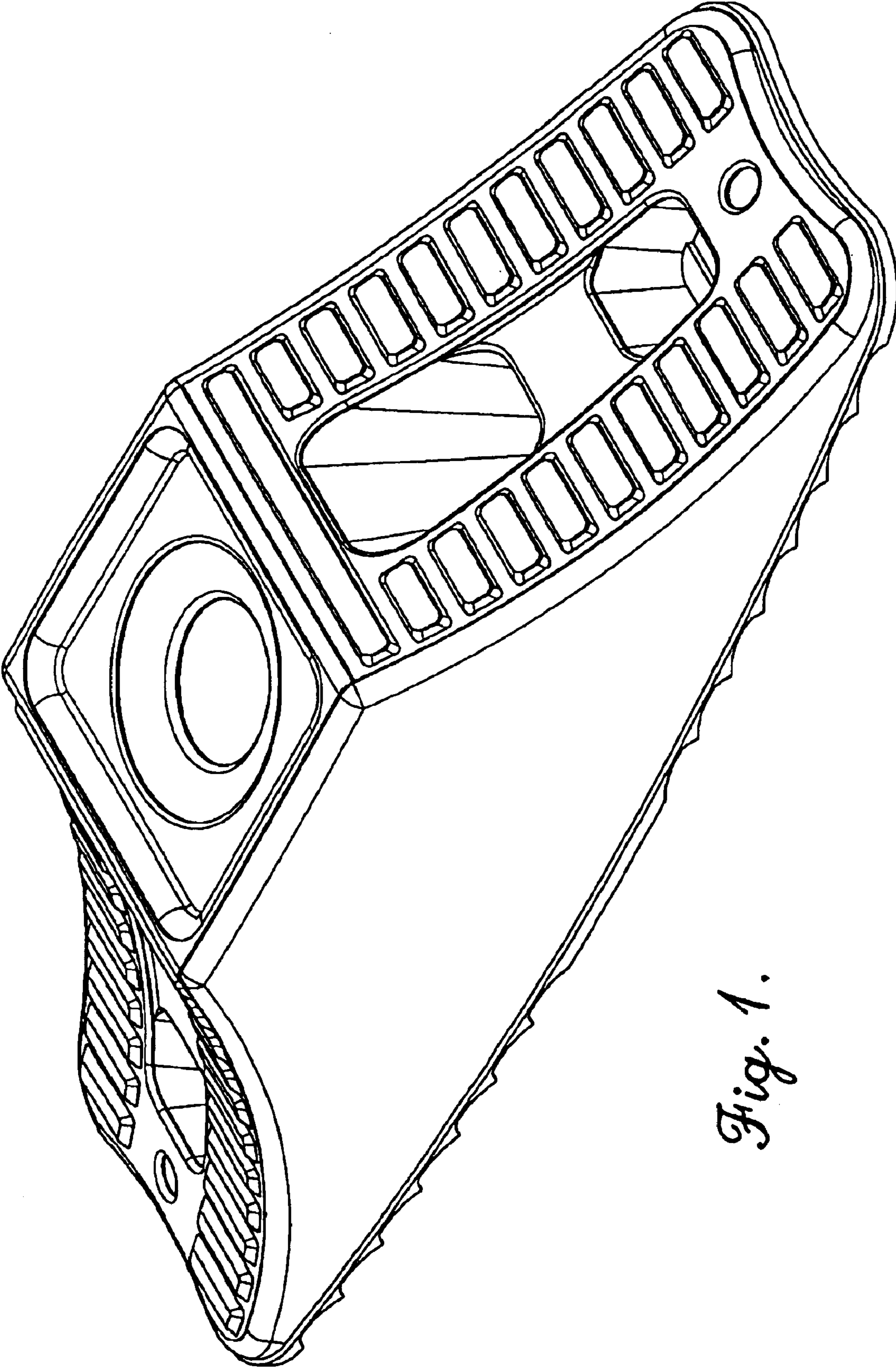
FIG. 3 is a side elevation view of the combination tandem axle wheel chock and trailer tongue stand depicted in FIG. 1, with the opposite side elevation being a mirror image thereof;

FIG. 4 is an end elevation view of the combination tandem axle wheel chock and trailer tongue stand depicted in FIG. 1, with the opposite end elevation view being a mirror image thereof; and,

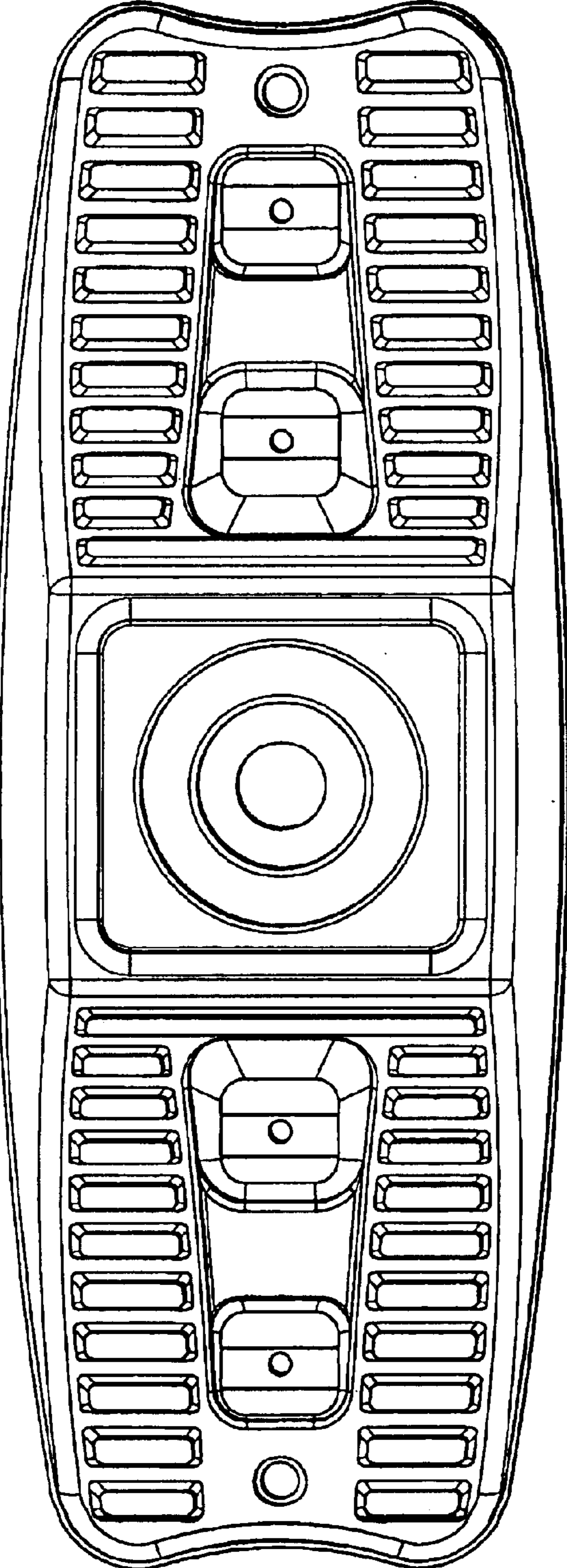
FIG. 5 is a bottom view of the combination tandem axle wheel chock and trailer tongue stand depicted in FIG. 1.

**1 Claim, 3 Drawing Sheets**

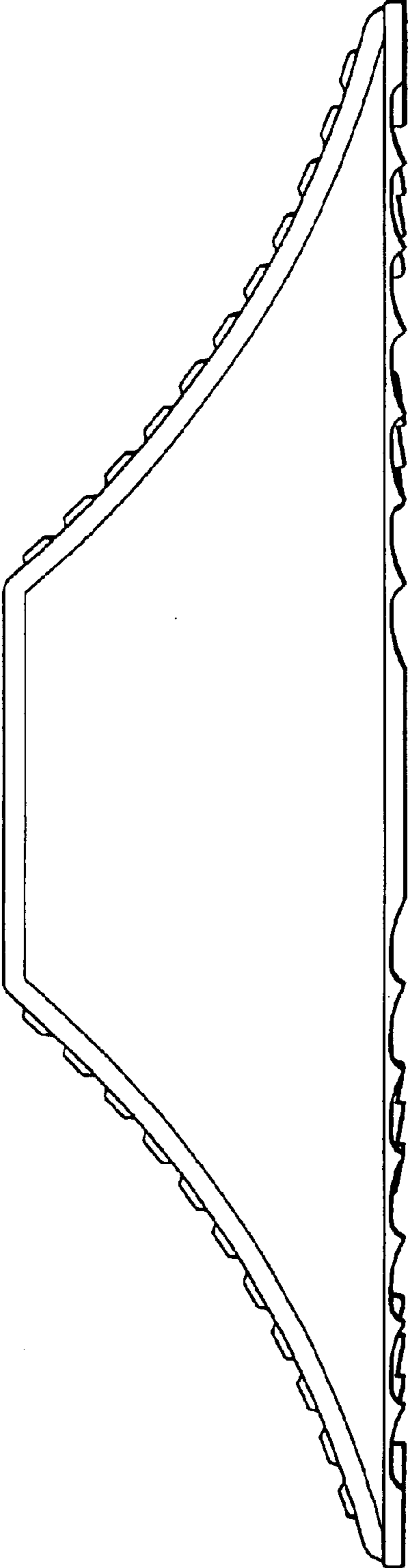




*Fig. 1.*

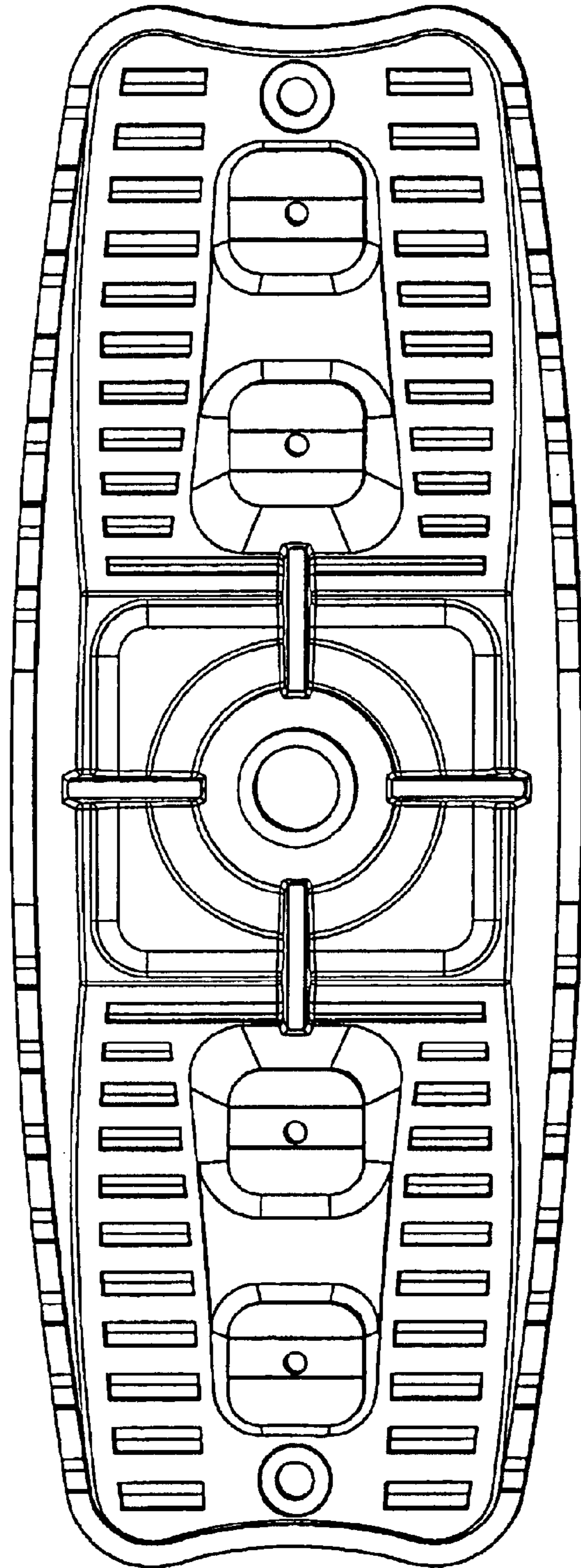
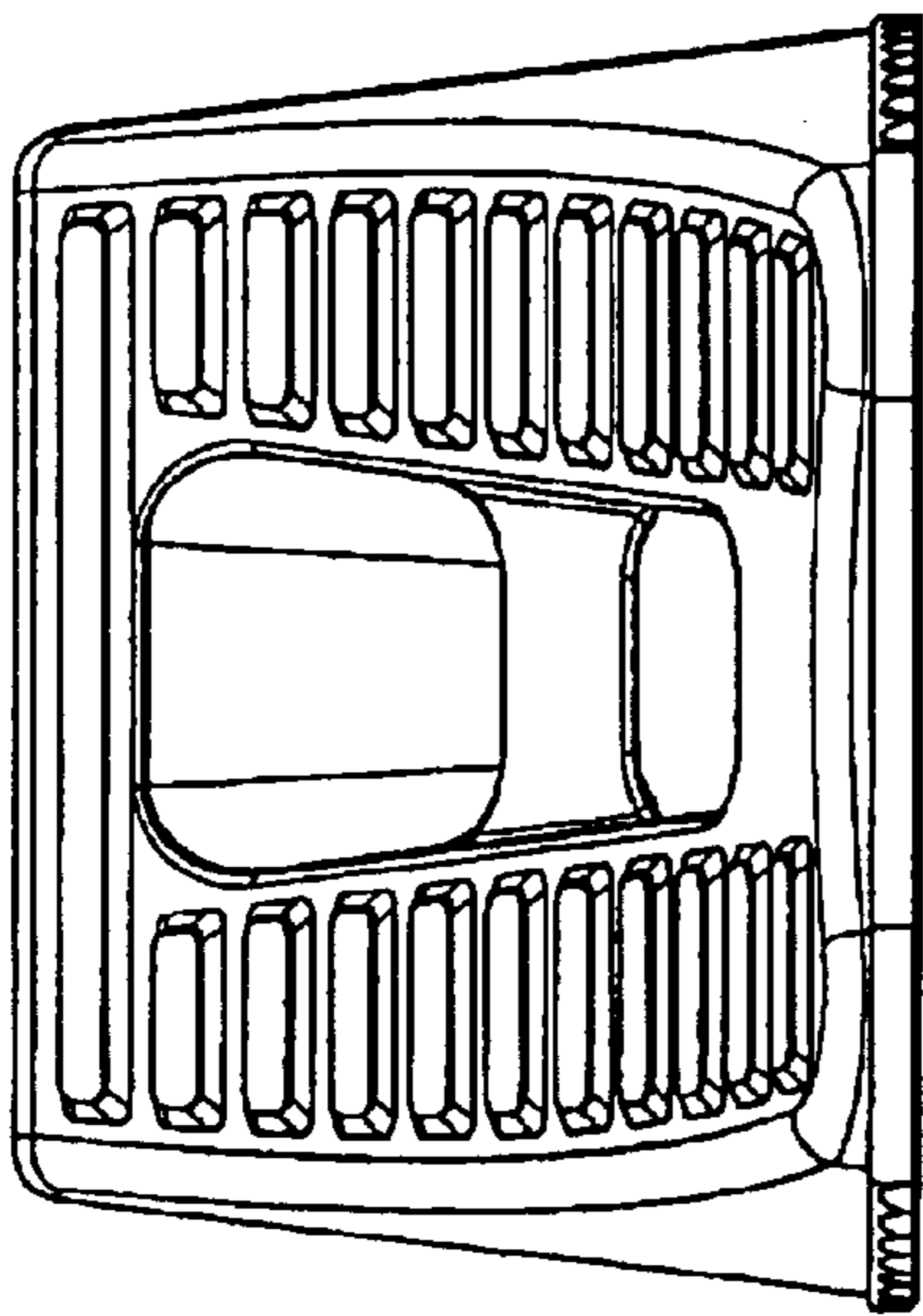


*Fig. 2.*



*Fig. 3.*

*Fig. 4.*



*Fig. 5.*