

US00D502126S

(12) **United States Design Patent**
Everitt et al.

(10) **Patent No.: US D502,126 S**
(45) **Date of Patent: ** Feb. 22, 2005**

(54) **MOTORING BIKE**

D395,849 S * 7/1998 Maruyama et al. D12/110
D472,852 S * 4/2003 Chen et al. D12/110

(75) Inventors: **Stephen Everitt**, London (GB);
Benjamin Wood, London (GB);
Stephen Thompson, Staffordshire
(GB); **Gavin Palmer**, London (GB);
Clive Kilford, London (GB); **Nicholas
Carpenter**, London (GB); **David
Minty**, London (GB); **Glen Rees**,
London (GB); **David Rendall**, London
(GB)

OTHER PUBLICATIONS

Choppers Inc. Motorcycle on p. 12 of 59 from: <URL :
[http://community.webshots.com/photo/85557545/
85559904XPedlr](http://community.webshots.com/photo/85557545/85559904XPedlr). © 1995–2004, retrieved from the Internet
Jun. 8, 2004.*

* cited by examiner

Primary Examiner—Alan P. Douglas
Assistant Examiner—Linda Brooks

(73) Assignee: **Brumby Corporation**, Isle of Man
(VG)

(74) *Attorney, Agent, or Firm*—Banner & Witcoff Ltd.

(**) Term: **14 Years**

(57) **CLAIM**

(21) Appl. No.: **29/172,102**

The ornamental design for a motoring bike, as shown and
described.

(22) Filed: **Dec. 6, 2002**

DESCRIPTION

(30) **Foreign Application Priority Data**

Jun. 7, 2002 (GB) 3004198

(51) **LOC (7) Cl.** **12-11**

(52) **U.S. Cl.** **D12/110**

(58) **Field of Search** D12/110; 180/219

FIG. 1 is a side elevational view of one side of a motoring
bike showing an embodiment of our new design;
FIG. 2 is a side elevational view of the opposite side thereof;
FIG. 3 is a top plan view thereof;
FIG. 4 is a front elevational view thereof;
FIG. 5 is a rear elevational view thereof;
FIG. 6 is a bottom plan view thereof; and,
FIG. 7 is a perspective view thereof.

(56) **References Cited**

U.S. PATENT DOCUMENTS

D387,017 S * 12/1997 Wakita et al. D12/110

1 Claim, 7 Drawing Sheets

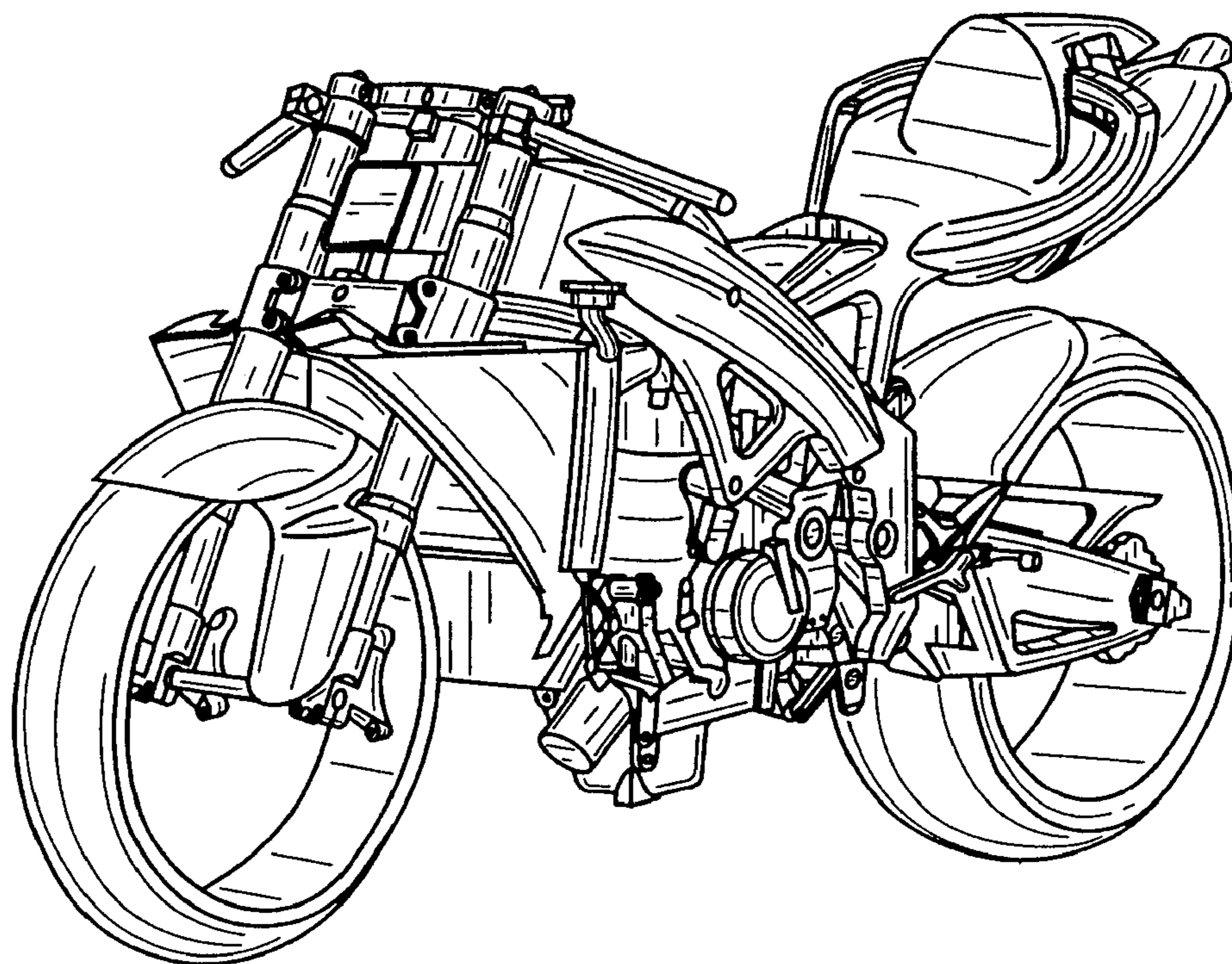

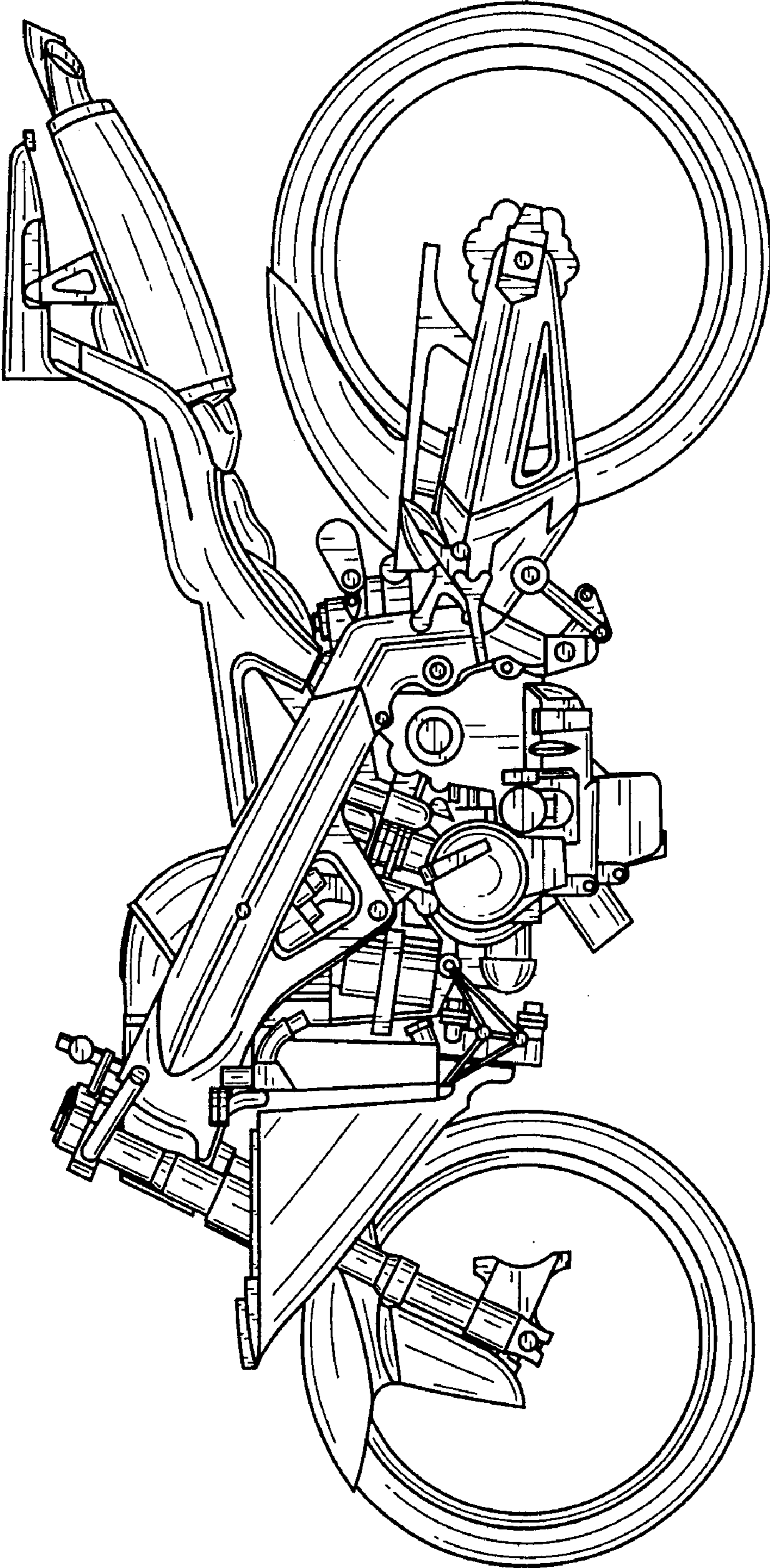

FIG. 1

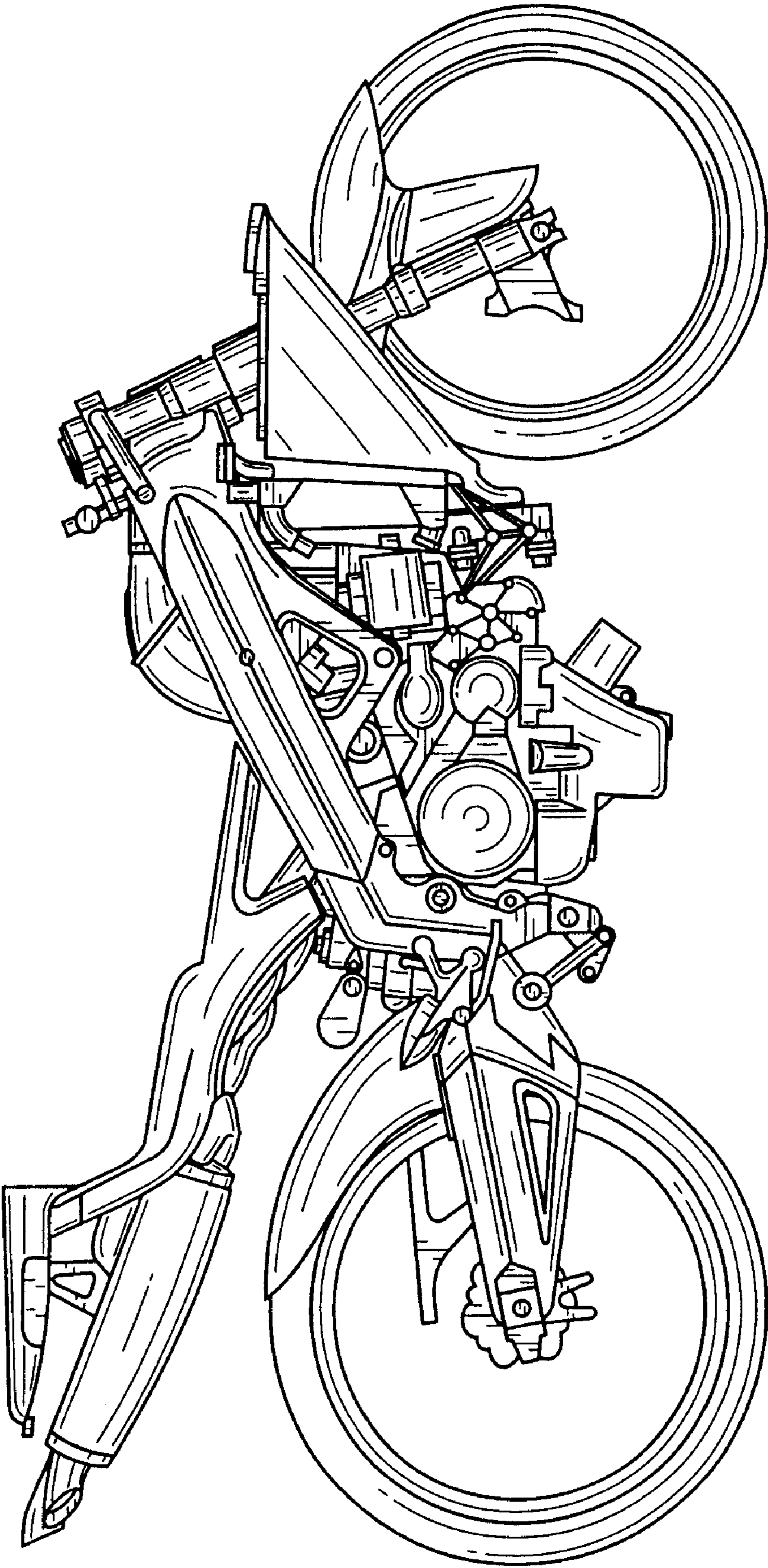

FIG. 2

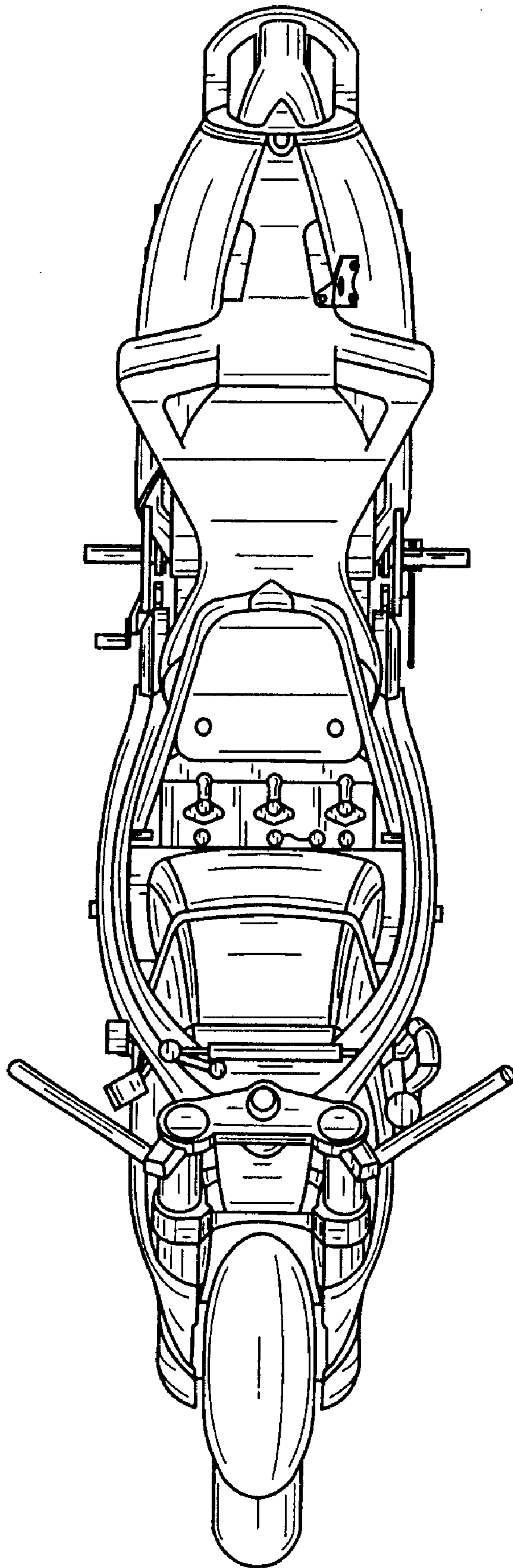

FIG. 3

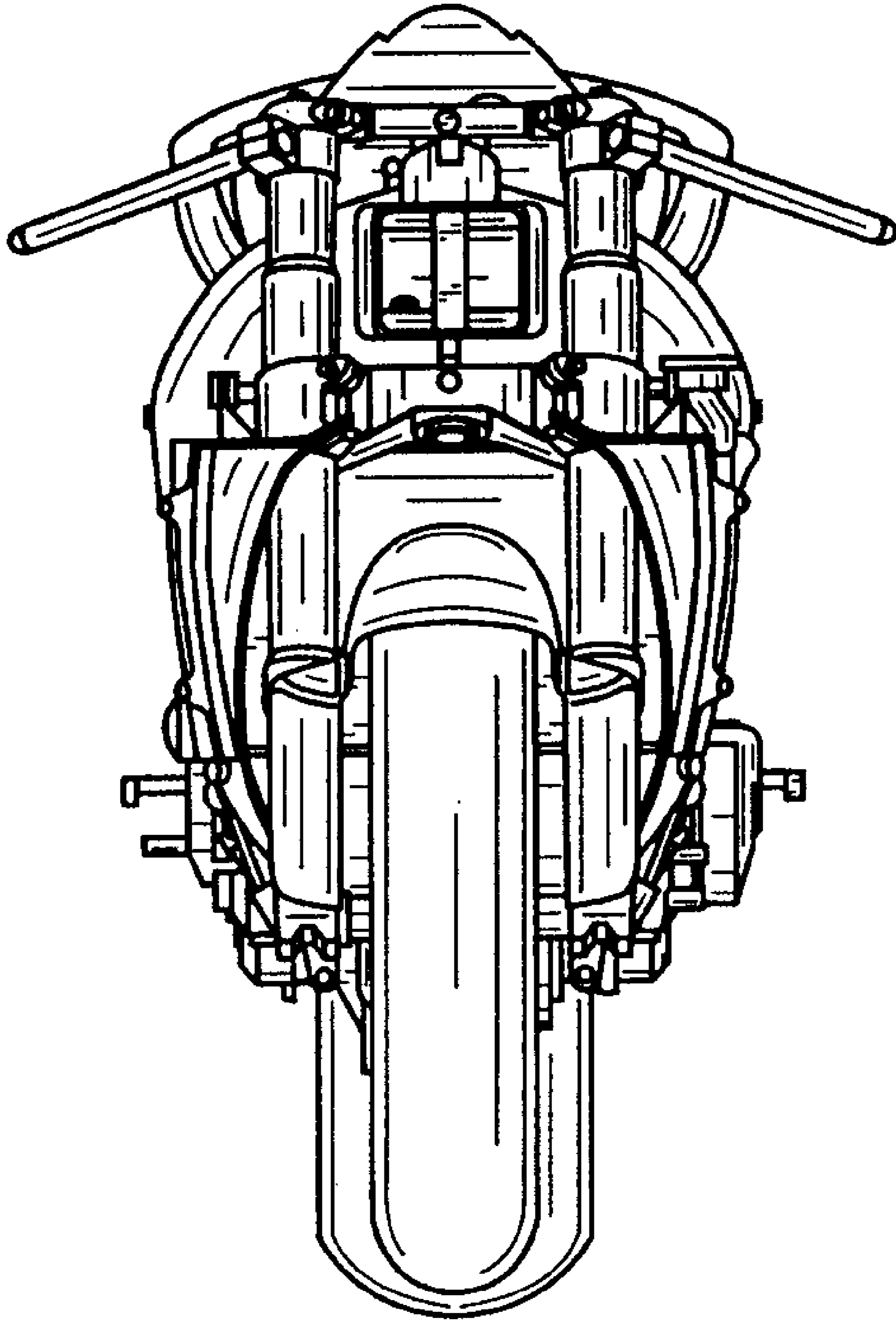

FIG. 4

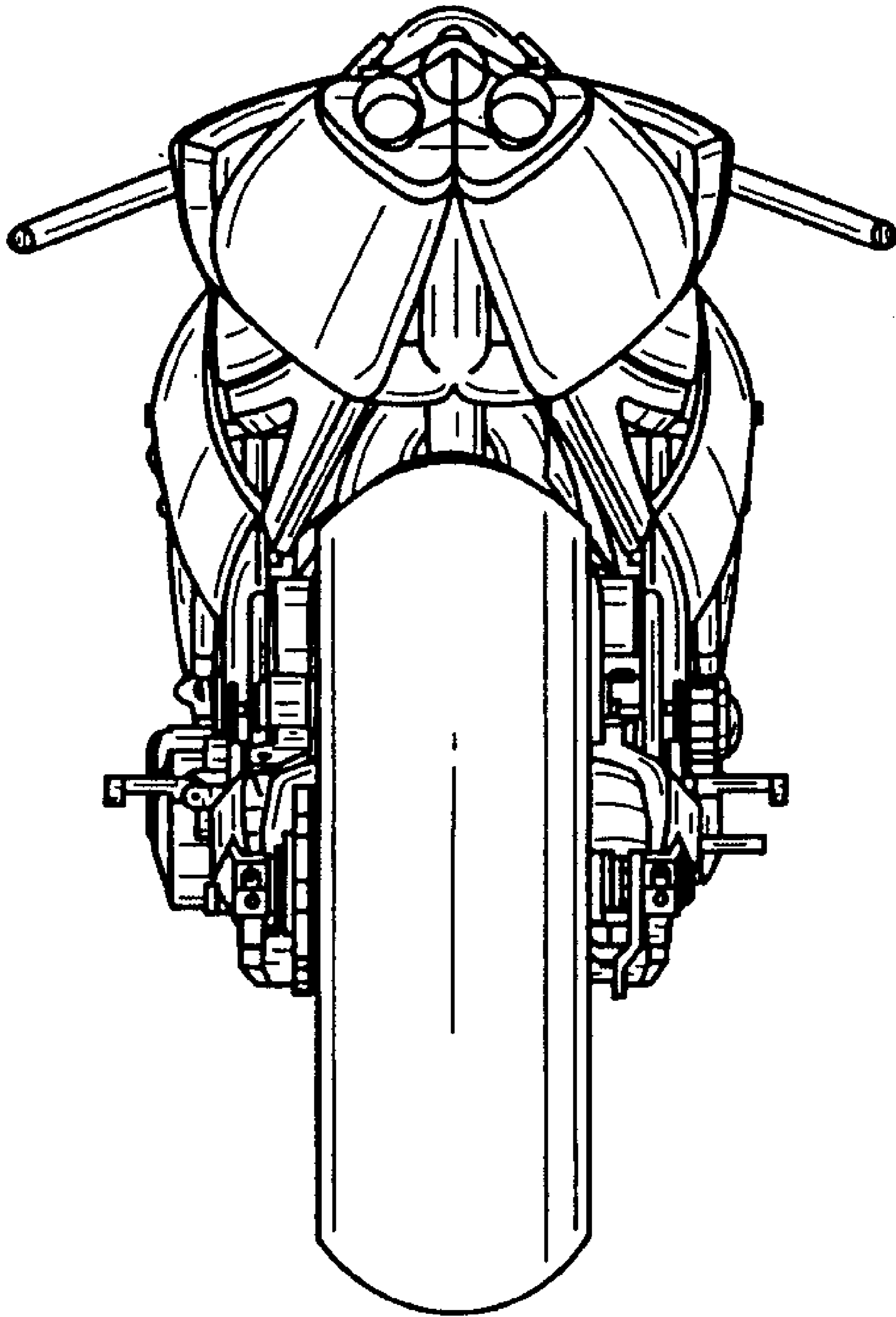

FIG. 5

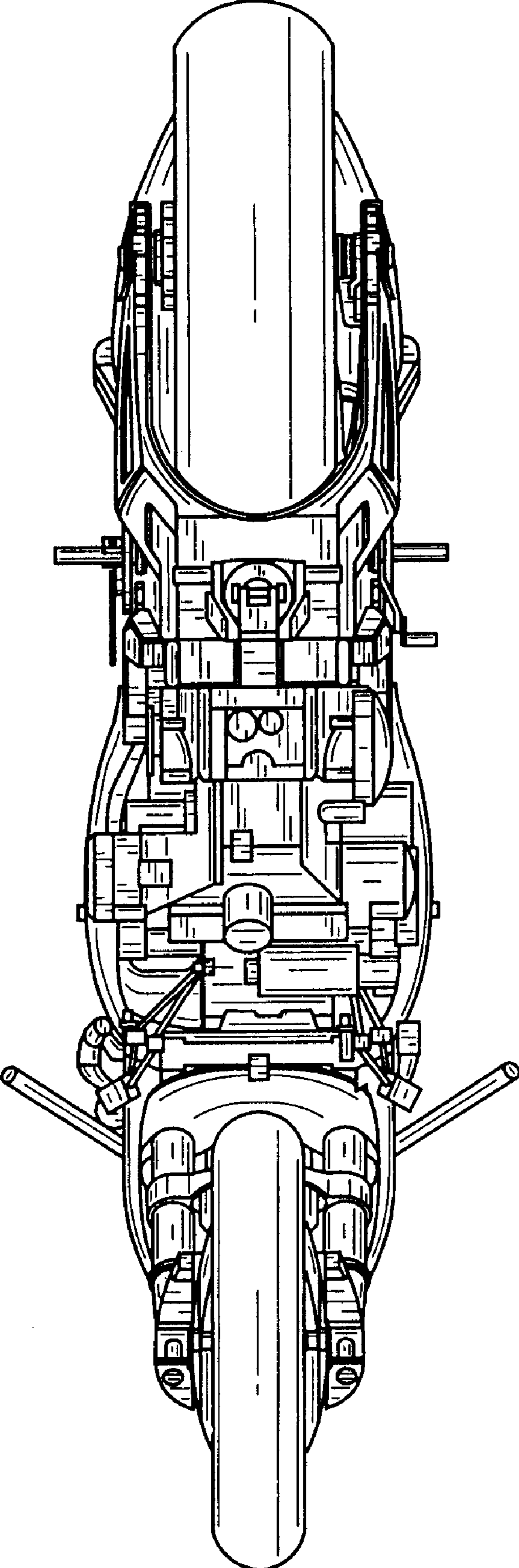

FIG. 6

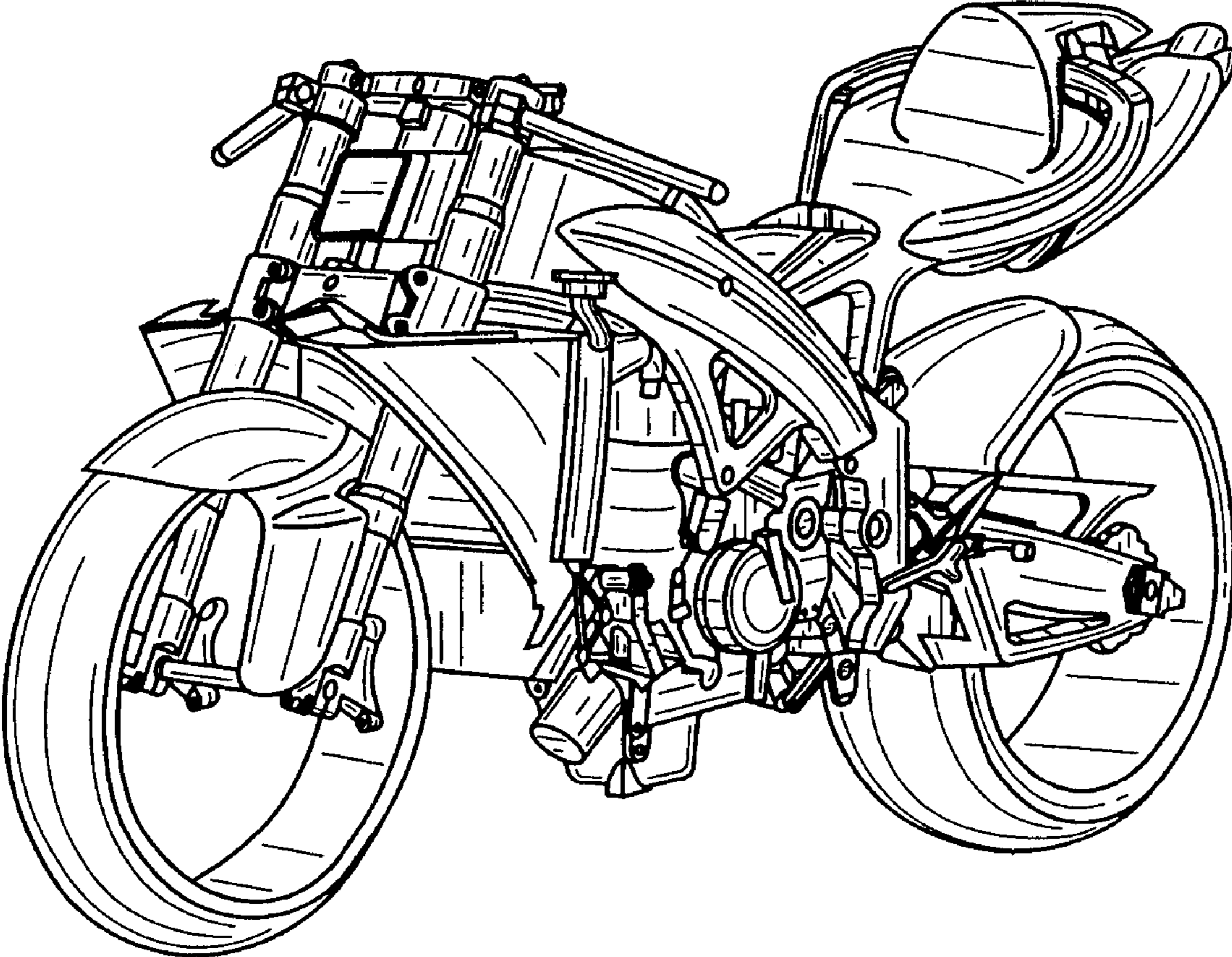

FIG. 7