

US00D501178S

(12) **United States Design Patent**  
**Han**

(10) **Patent No.:** **US D501,178 S**  
(45) **Date of Patent:** **\*\* Jan. 25, 2005**

(54) **TRIPLE ENGINE JET FIGHTER DOUBLE SEATER DESIGN**

D467,533 S \* 12/2002 Han ..... D12/319  
D477,561 S \* 7/2003 Nelson ..... D12/319  
D479,501 S \* 9/2003 Nelson ..... D12/319

(76) Inventor: **Charlie K. Han**, 620 Heirloom Ter.,  
Fremont, CA (US) 94536

\* cited by examiner

(\*\*) Term: **14 Years**

*Primary Examiner*—Marcus A. Jackson

(21) Appl. No.: **29/206,745**

(22) Filed: **Jun. 3, 2004**

(57) **CLAIM**

The ornamental design for a triple engine jet fighter double seater design, as shown and described.

(51) **LOC (7) Cl.** ..... **12-12**

(52) **U.S. Cl.** ..... **D12/319**

(58) **Field of Search** ..... D12/319-345;  
244/45 A, 45 R, 13, 15, 91, 211, 218

**DESCRIPTION**

FIG. 1 is a front elevational view of a triple engine jet fighter double seater design;  
FIG. 2 is a side elevational view thereof, with the opposite side being a mirror image;  
FIG. 3 is a top plan view thereof; and,  
FIG. 4 is a perspective view thereof.

(56) **References Cited**

**U.S. PATENT DOCUMENTS**

D458,577 S \* 6/2002 Han ..... D12/319

**1 Claim, 4 Drawing Sheets**

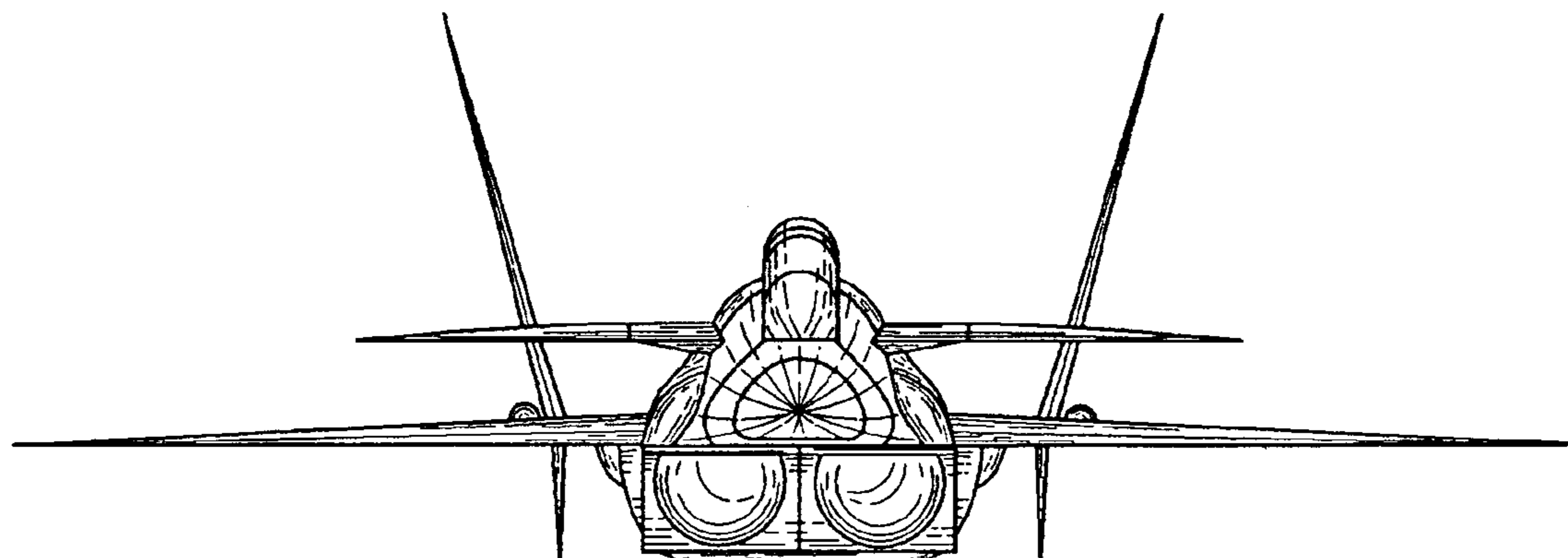

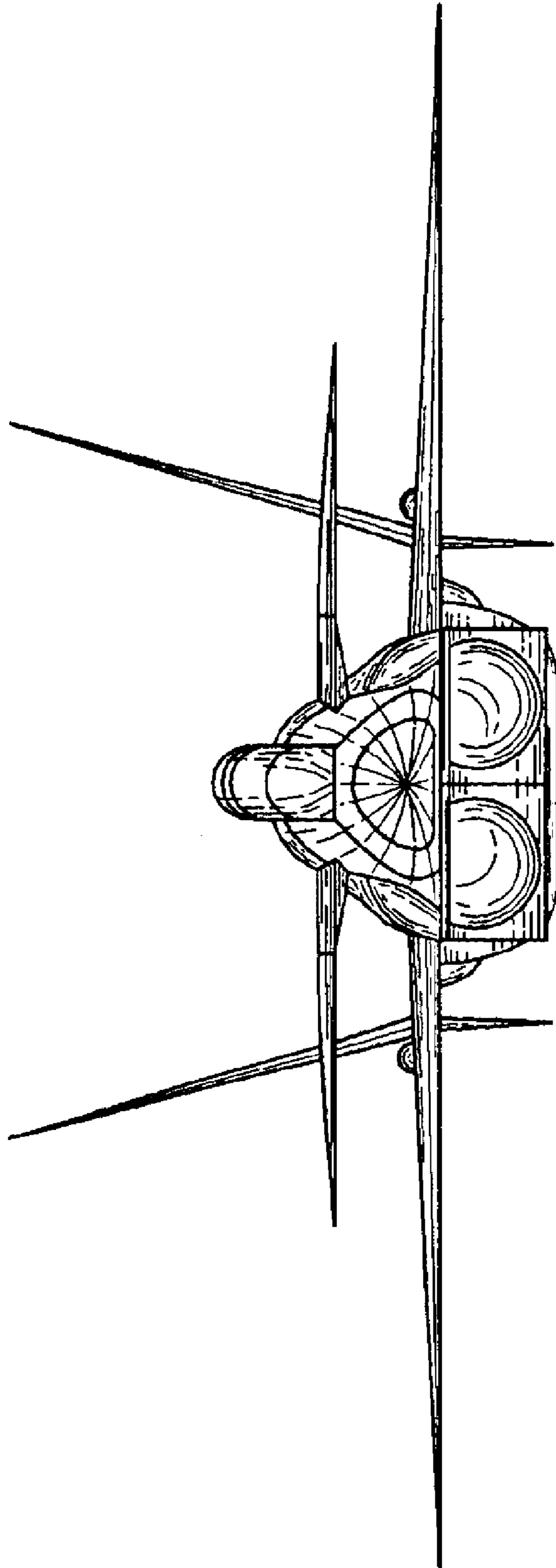

Fig. 1



Fig. 2

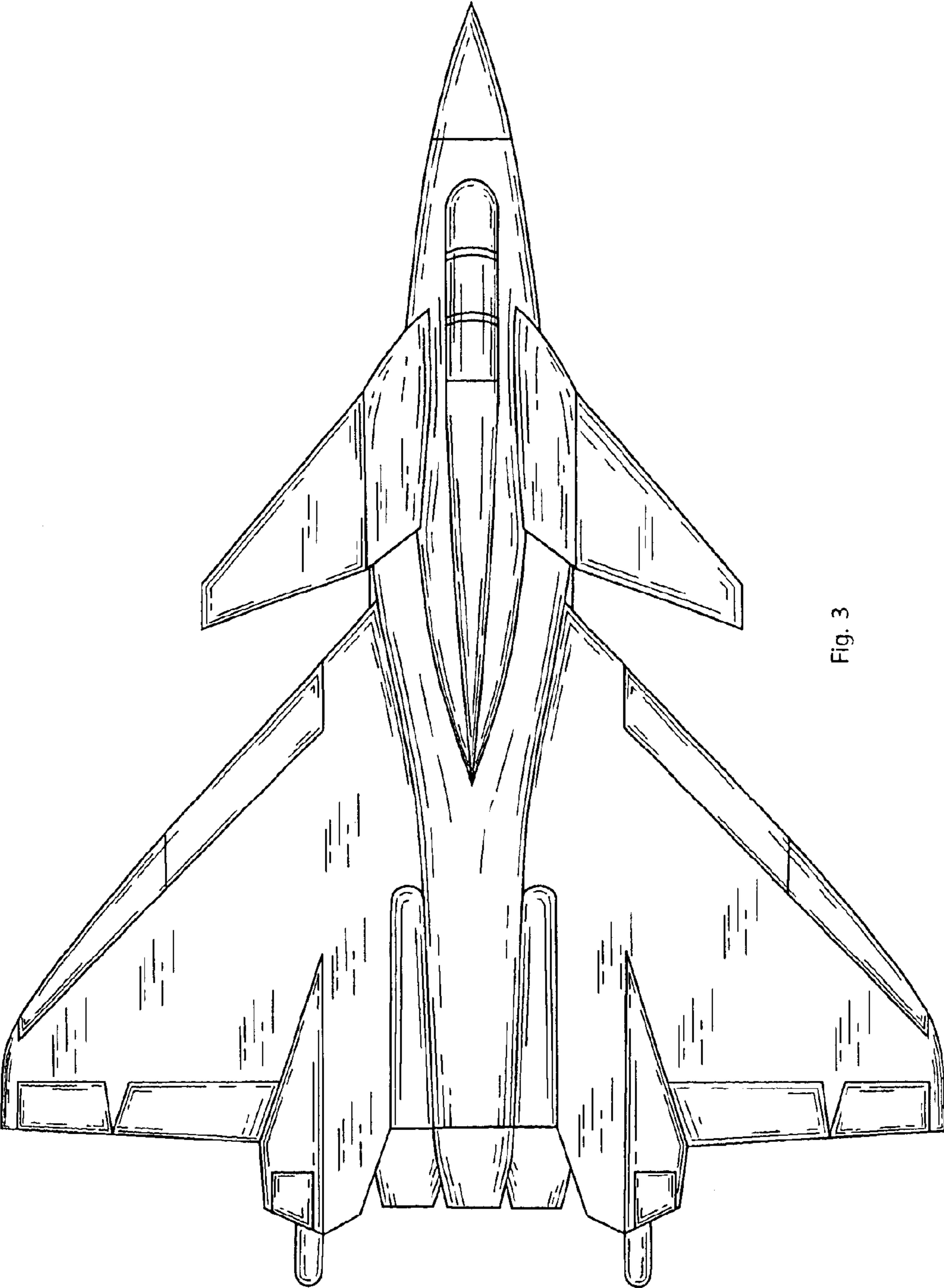

Fig. 3

TOP VIEW

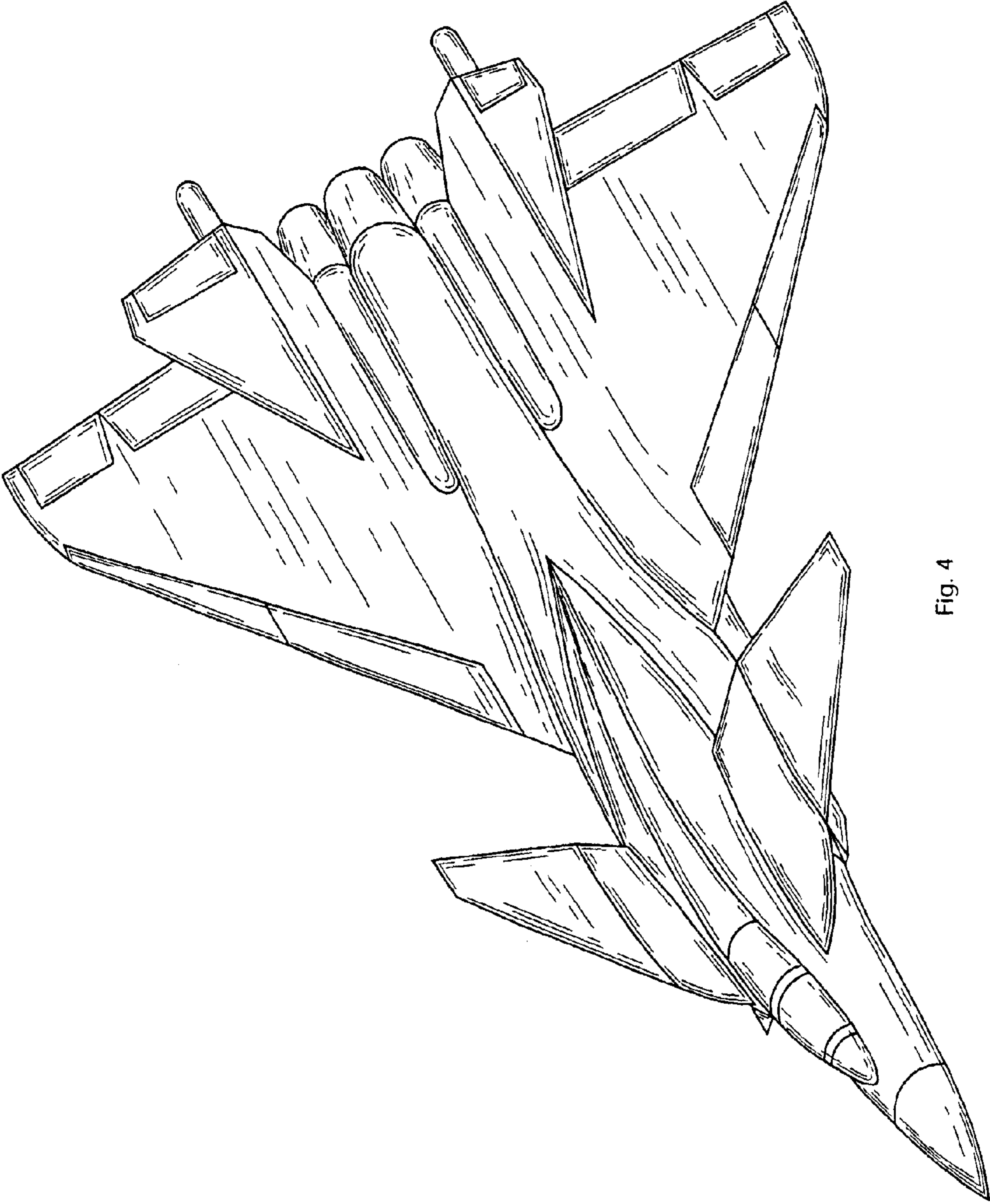

Fig. 4

PERSPECTIVE VIEW