

US00D500981S

(12) **United States Design Patent**  
**Wilding et al.**

(10) **Patent No.: US D500,981 S**  
(45) **Date of Patent: \*\* Jan. 18, 2005**

(54) **AIRCRAFT**  
(75) Inventors: **Joe Wilding**, Elizabeth, CO (US);  
**Dennis D. Olcott**, Lone Tree, CO (US);  
**Greg Cole**, Bend, OR (US)

(73) Assignee: **Adam Aircraft Industries**, Englewood,  
CO (US)

(\*\*) Term: **14 Years**

(21) Appl. No.: **29/200,129**

(22) Filed: **Feb. 25, 2004**

(51) **LOC (7) Cl.** ..... **12-99**

(52) **U.S. Cl.** ..... **D12/319**

(58) **Field of Search** ..... D12/319-345;  
244/45 A, 45 R, 13, 36, 37

(56) **References Cited**

**U.S. PATENT DOCUMENTS**

1,726,558 A	9/1929	Hall
1,928,326 A	9/1933	Bratu
D100,609 S	7/1936	Wilson et al.
D106,275 S	10/1937	Bellanca
2,140,783 A	12/1938	Bellanca
D116,206 S	8/1939	McKellar
D117,419 S	10/1939	Munk et al.
D130,651 S	12/1941	Silverstein
D138,795 S	9/1944	Stoughton et al.
D162,517 S	3/1951	Burnelli
2,699,299 A	1/1955	Herrick
3,018,987 A	1/1962	Multhopp
D192,195 S	2/1962	Stepniewski
3,181,820 A	5/1965	Burnelli
D203,720 S	2/1966	Jarchow et al.
3,981,460 A	9/1976	Ratony

4,298,175 A	11/1981	Earl
D304,821 S	11/1989	Ratony
D319,805 S	* 9/1991	Wiegert ..... D12/319
5,320,306 A	6/1994	Gennaro
D354,936 S	1/1995	Kraft et al.
5,979,824 A	11/1999	Gagliano et al.
D446,182 S	* 8/2001	Adam et al. .... D12/319

**OTHER PUBLICATIONS**

Endres, Gunter et al., *Janes' Aircraft Recognition Guide*,  
2002, p. 210, HarperCollinsPublishers Inc., New York, NY.

\* cited by examiner

*Primary Examiner*—Marcus A. Jackson

(74) *Attorney, Agent, or Firm*—Wiley, Rein & Fielding,  
LLP

(57) **CLAIM**

The ornamental design for an aircraft, as shown and  
described.

**DESCRIPTION**

FIG. 1 is a side elevational perspective of an aircraft  
according to the novel design.

FIG. 2 is a front perspective of an aircraft according to the  
novel design.

FIG. 3 is a side perspective of an aircraft according to a  
novel design.

FIG. 4 is a top perspective of an aircraft according to the  
novel design; and,

FIG. 5 is a bottom perspective of an aircraft according to the  
novel design.

The broken lines included in the drawings depict elements  
that are not part of the claimed design.

**1 Claim, 4 Drawing Sheets**

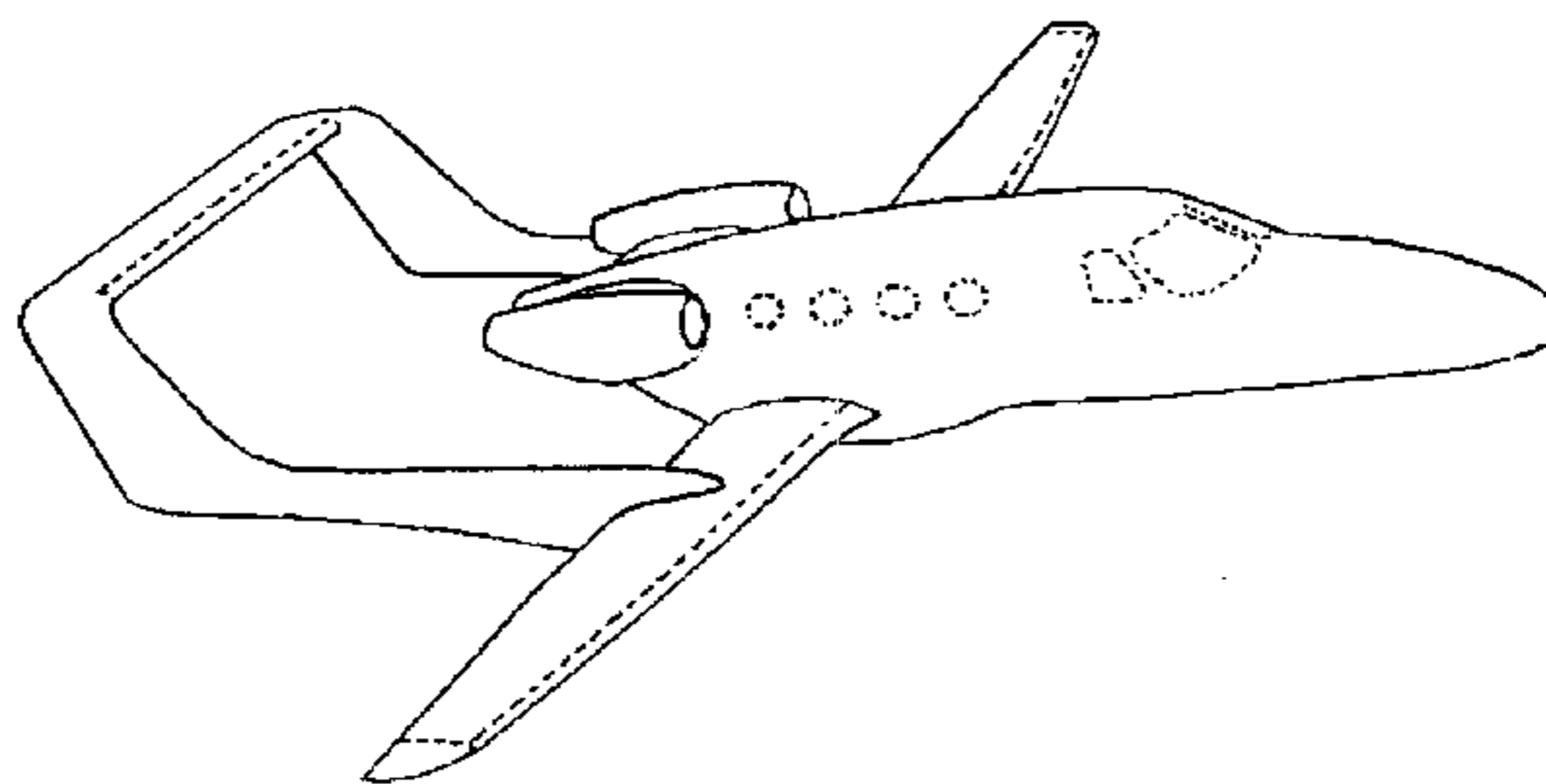

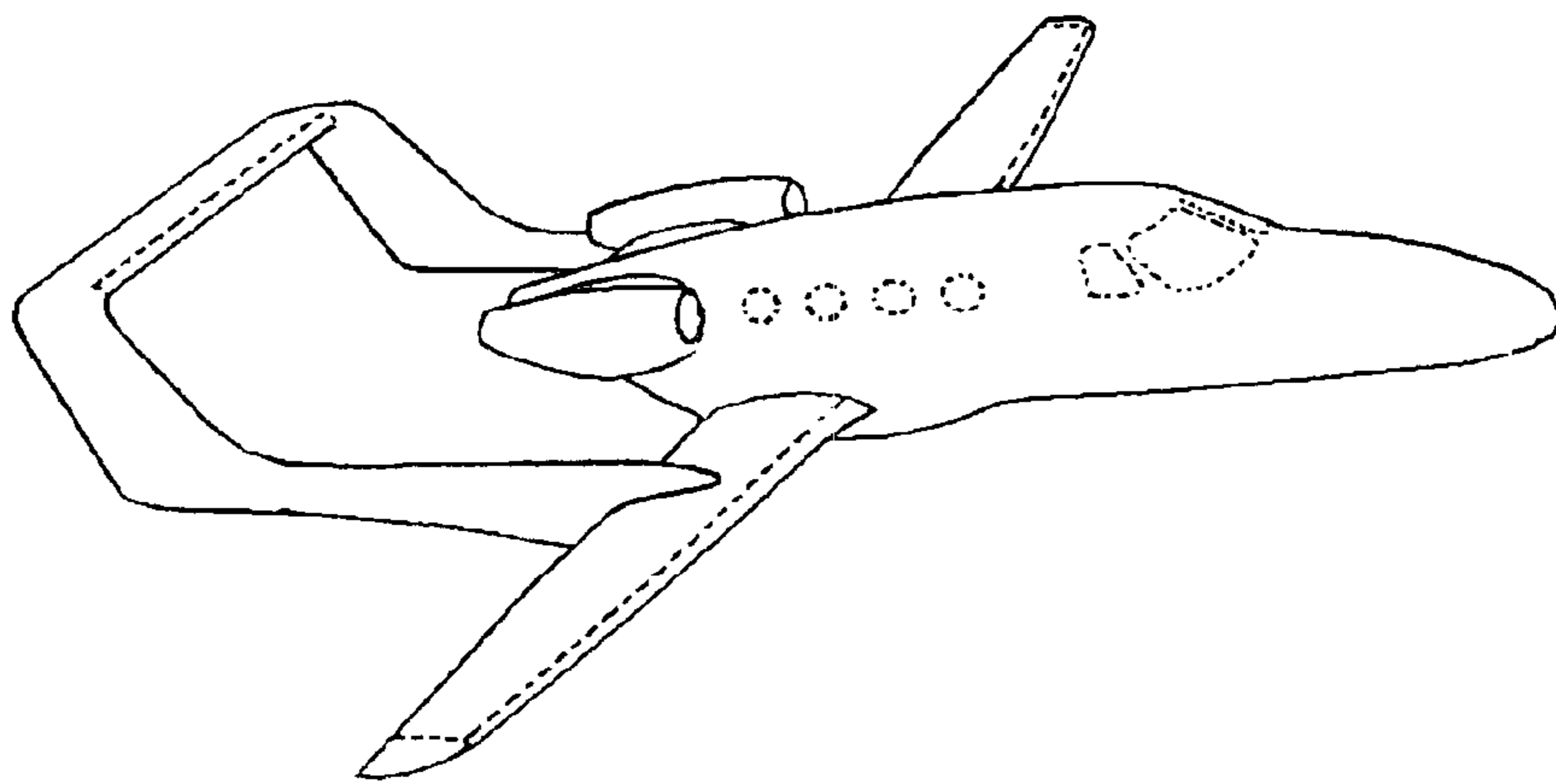

FIG. 1

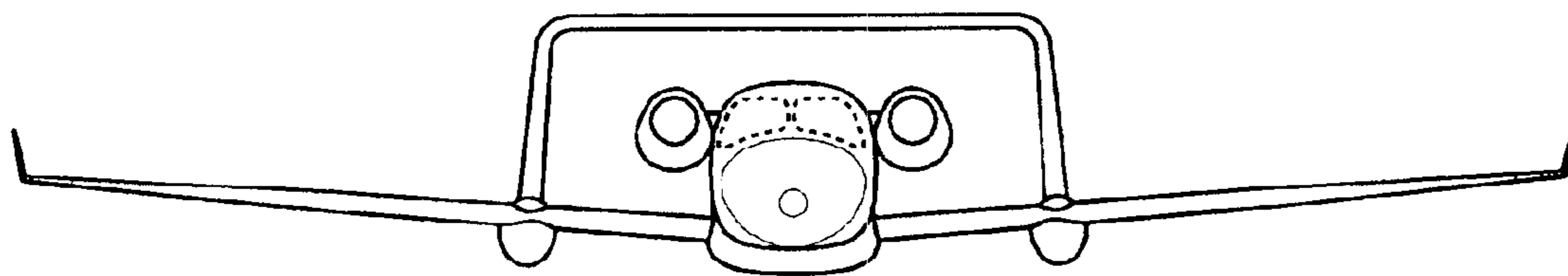

FIG. 2

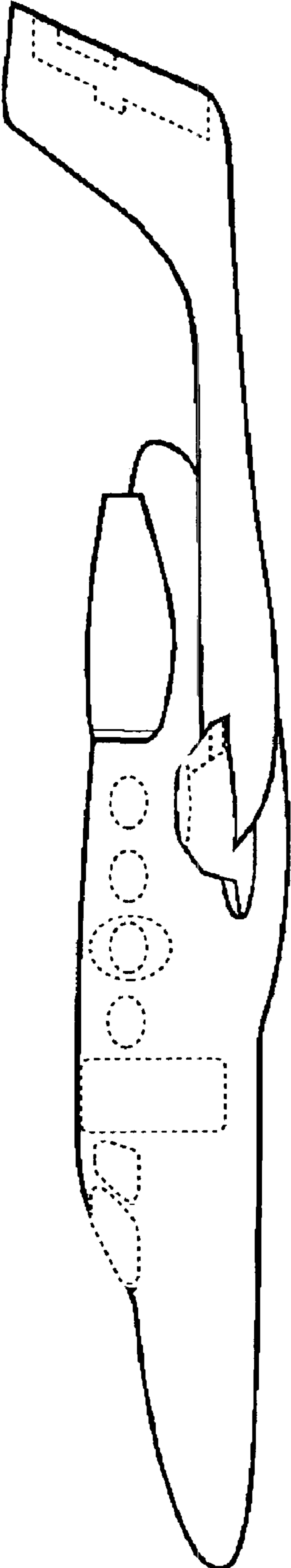

FIG. 3

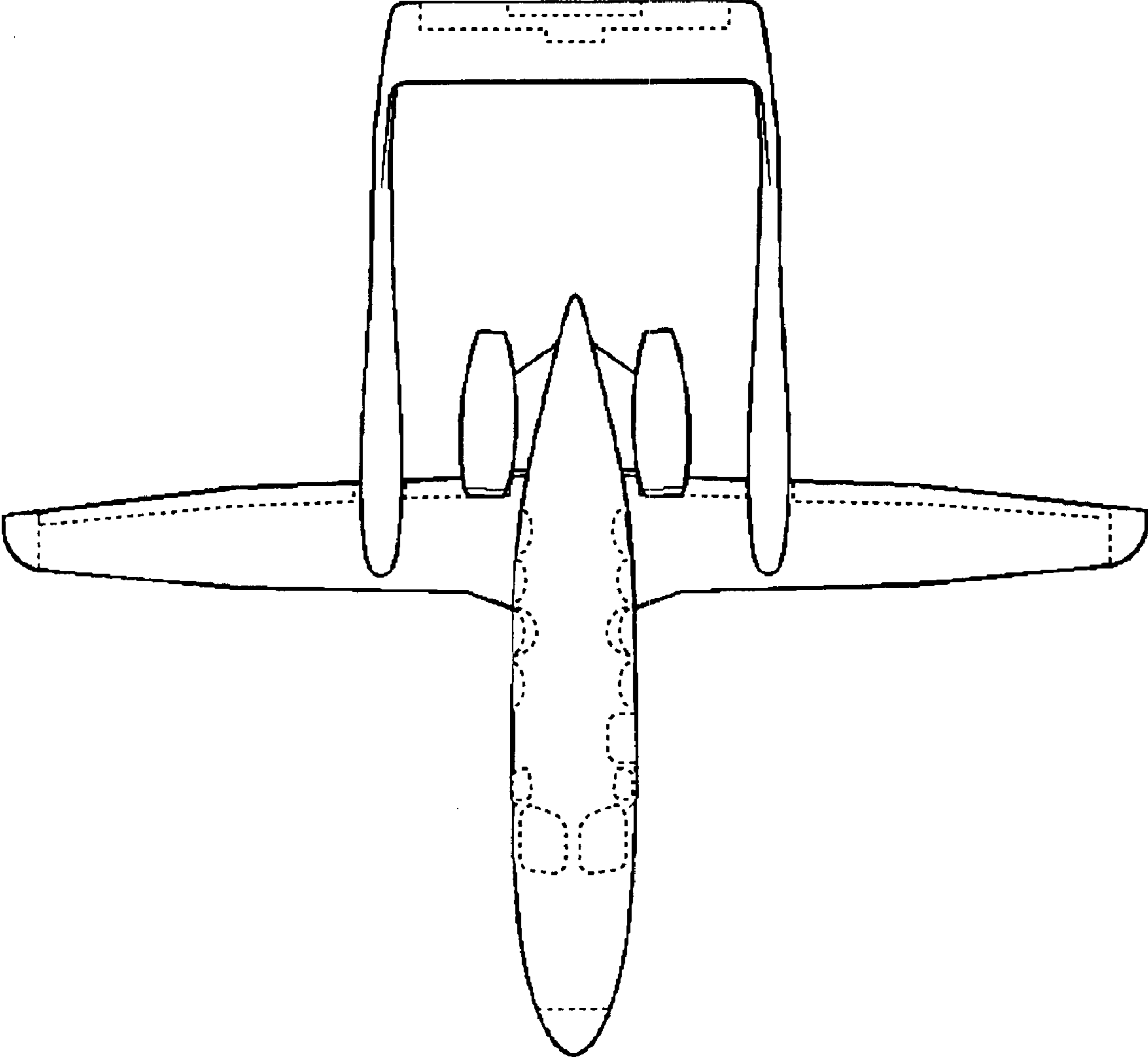

FIG. 4

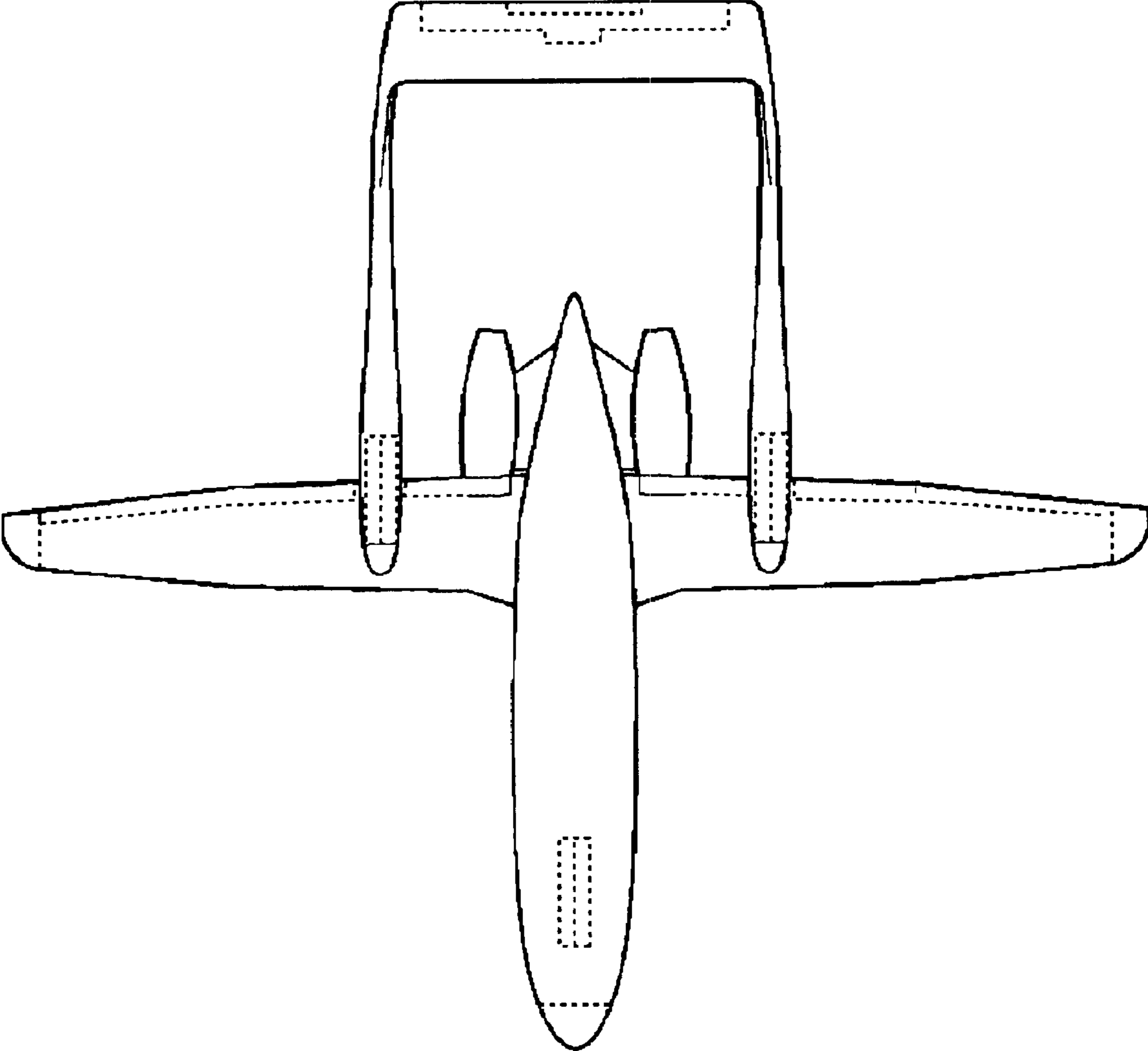

FIG. 5