

US00D500980S

(12) **United States Design Patent**  
**Eatkins et al.**

(10) **Patent No.: US D500,980 S**  
(45) **Date of Patent: \*\* Jan. 18, 2005**

(54) **PORTIONS OF A JET AIRPLANE**

D495,653 S \* 9/2004 Eatkins et al. .... D12/319  
D495,987 S \* 9/2004 Eatkins et al. .... D12/319

(75) Inventors: **Mark Eatkins**, Kirkland, WA (US);  
**Paul Dees**, Woodinville, WA (US);  
**Blake Emery**, Enumclaw, WA (US);  
**Chris B. Kettering**, Kirkland, WA  
(US); **Kevin Retz**, Bothell, WA (US);  
**Paul Mikulencak**, Everett, WA (US)

**OTHER PUBLICATIONS**

Pamphlet: *Plane Spotter: Your Guide to Passenger Airlines*  
© 1999.  
Bill Yenne, *The Story of the Boeing Company*, AGS Book-  
Works, San Francisco, CA © 2003.

(73) Assignee: **The Boeing Company**, Chicago, IL  
(US)

\* cited by examiner

*Primary Examiner*—Marcus A. Jackson

(\*\*) Term: **14 Years**

(57) **CLAIM**

(21) Appl. No.: **29/187,445**

The ornamental design for portions of a jet airplane, as  
shown and described.

(22) Filed: **Aug. 1, 2003**

**DESCRIPTION**

**Related U.S. Application Data**

(62) Division of application No. 29/181,153, filed on May 5,  
2003, now Pat. No. Des. 491,875.

FIG. 1 is a perspective view of the inventive portions of a jet  
airplane;  
FIG. 2 is a top plan view of the portions of the jet airplane;  
FIG. 3 is a front plan view of the portions of the jet airplane;  
FIG. 4 is a back plan view of the portions of the jet airplane;  
FIG. 5 is a side plan view of the portions of the jet airplane,  
with the opposite side being a mirror image thereof; and,  
FIG. 6 is a bottom plan view of the portions of the jet  
airplane.

(51) **LOC (7) Cl.** ..... **12-99**

(52) **U.S. Cl.** ..... **D12/319**

(58) **Field of Search** ..... D12/319-345;  
244/45 A, 45 R, 13, 15, 91, 198, 211, 218

Other portions of the jet airplane are shown in hidden lines.  
These form part of the environment of the present invention  
and are not part of the claimed invention.

(56) **References Cited**

**U.S. PATENT DOCUMENTS**

D491,875 S \* 6/2004 Eatkins et al. .... D12/319  
D494,127 S \* 8/2004 Eatkins et al. .... D12/319  
D494,920 S \* 8/2004 Eatkins et al. .... D12/319

**1 Claim, 5 Drawing Sheets**

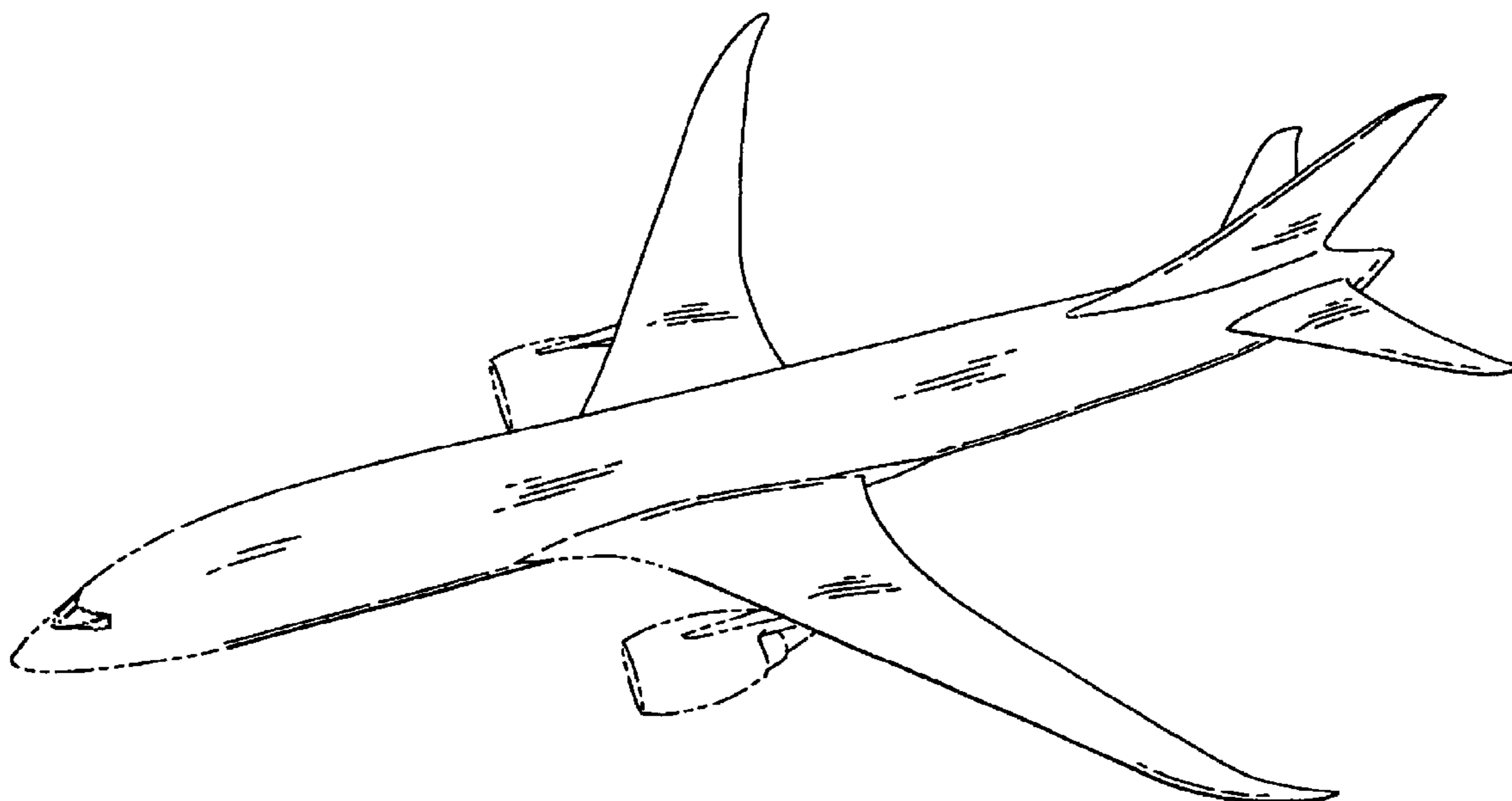

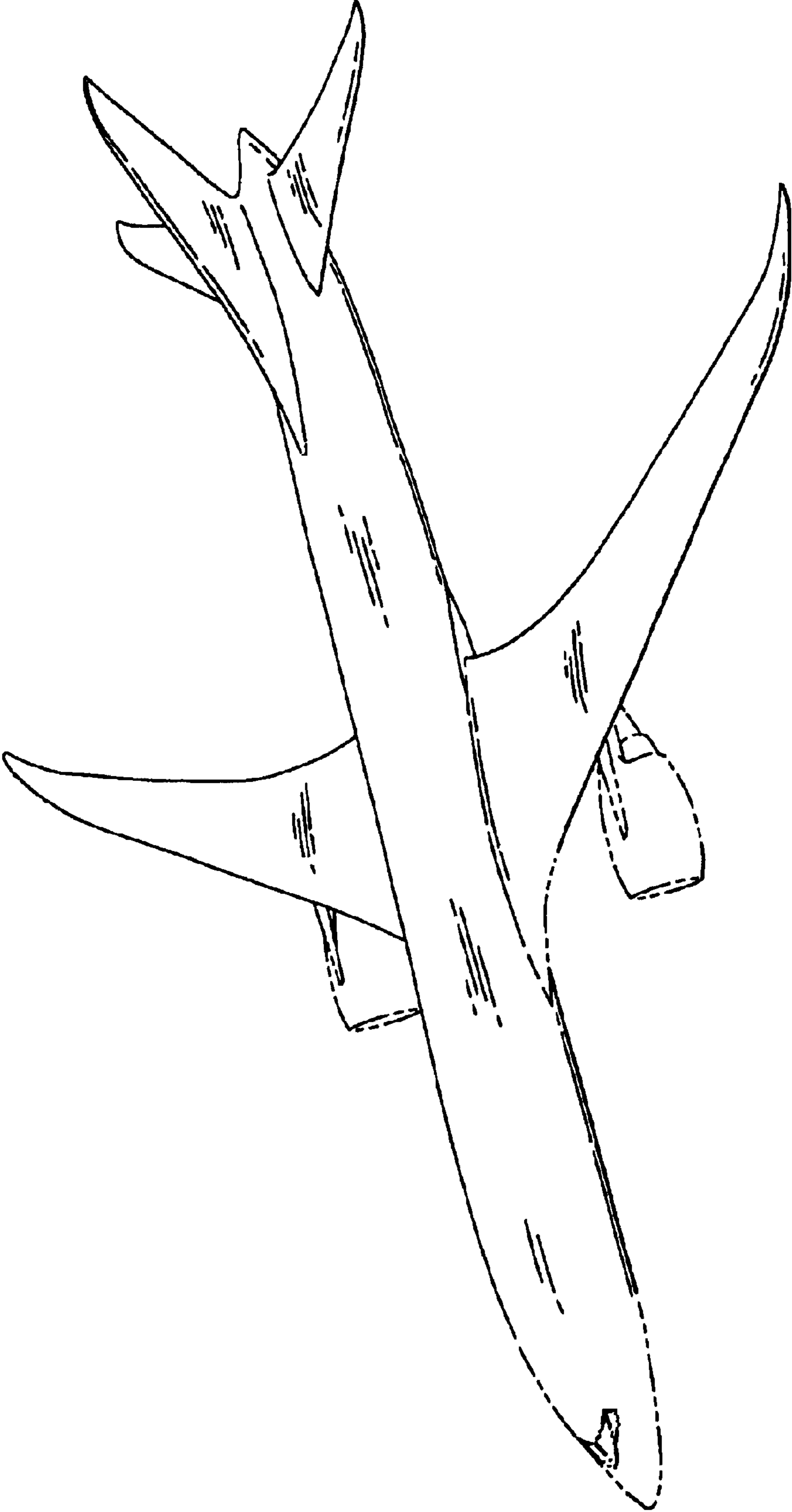

FIG. 1

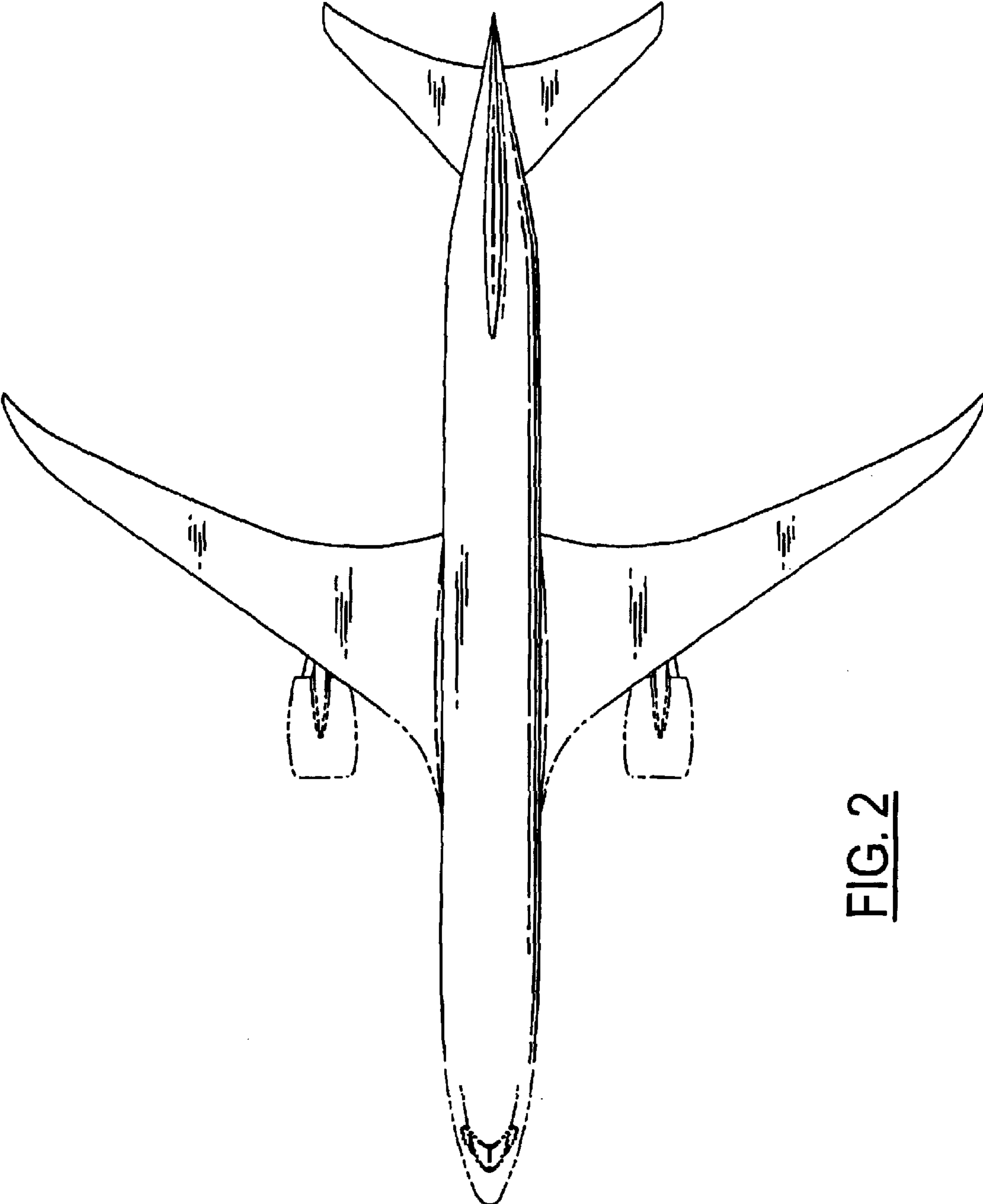

FIG. 2

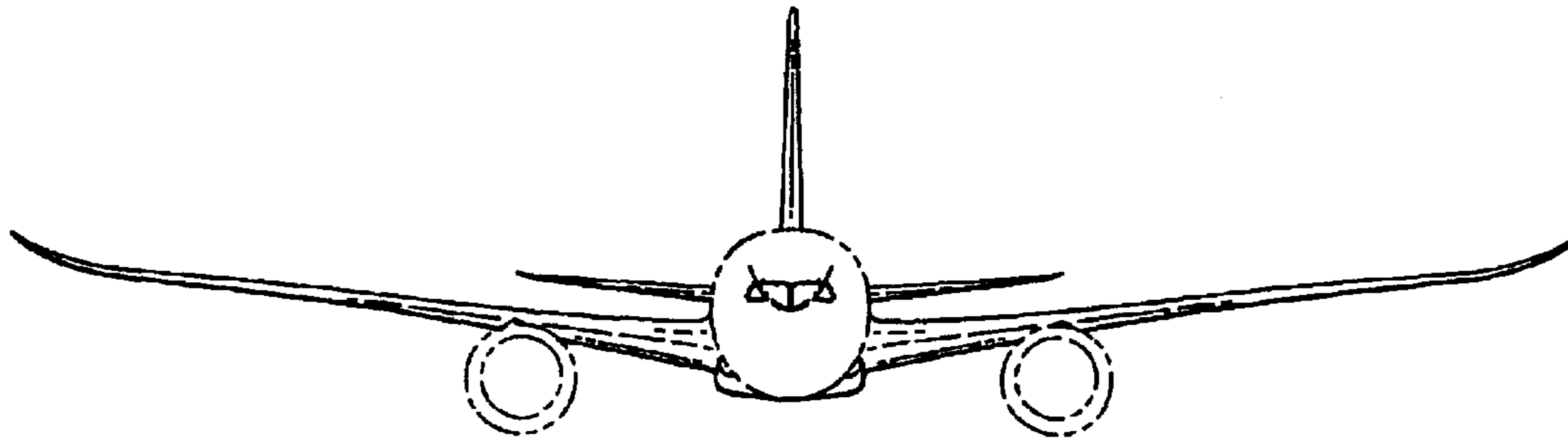

FIG. 3

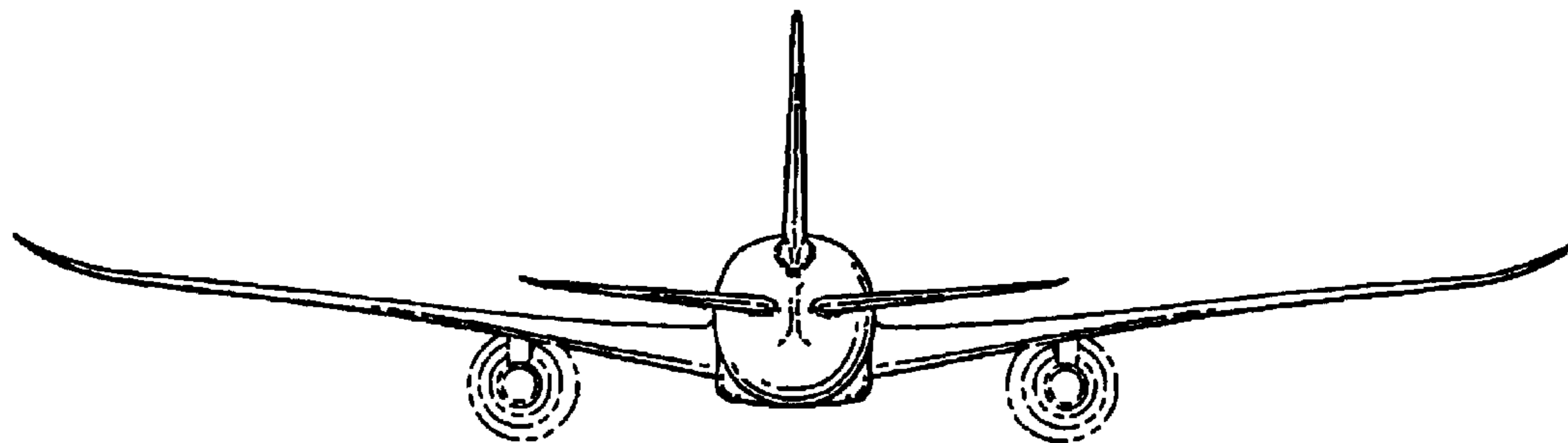

FIG. 4

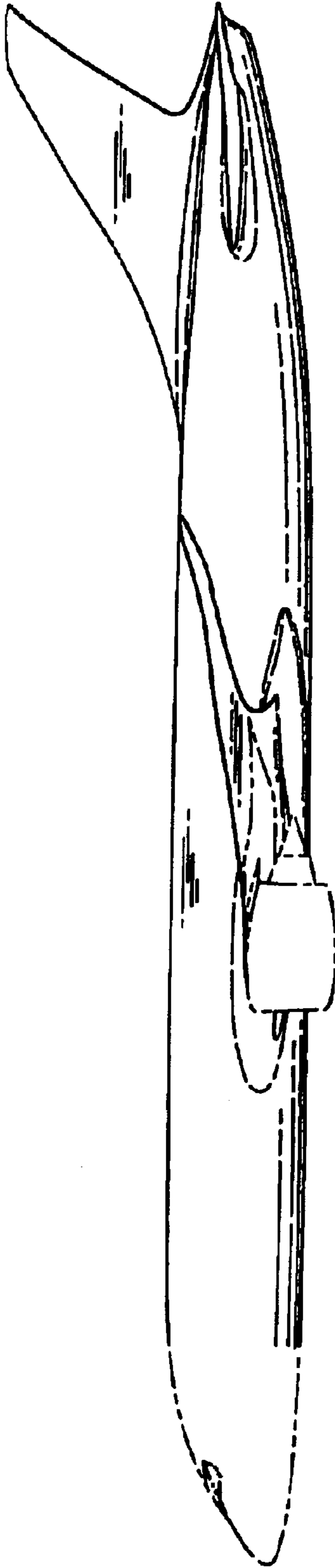

FIG. 5

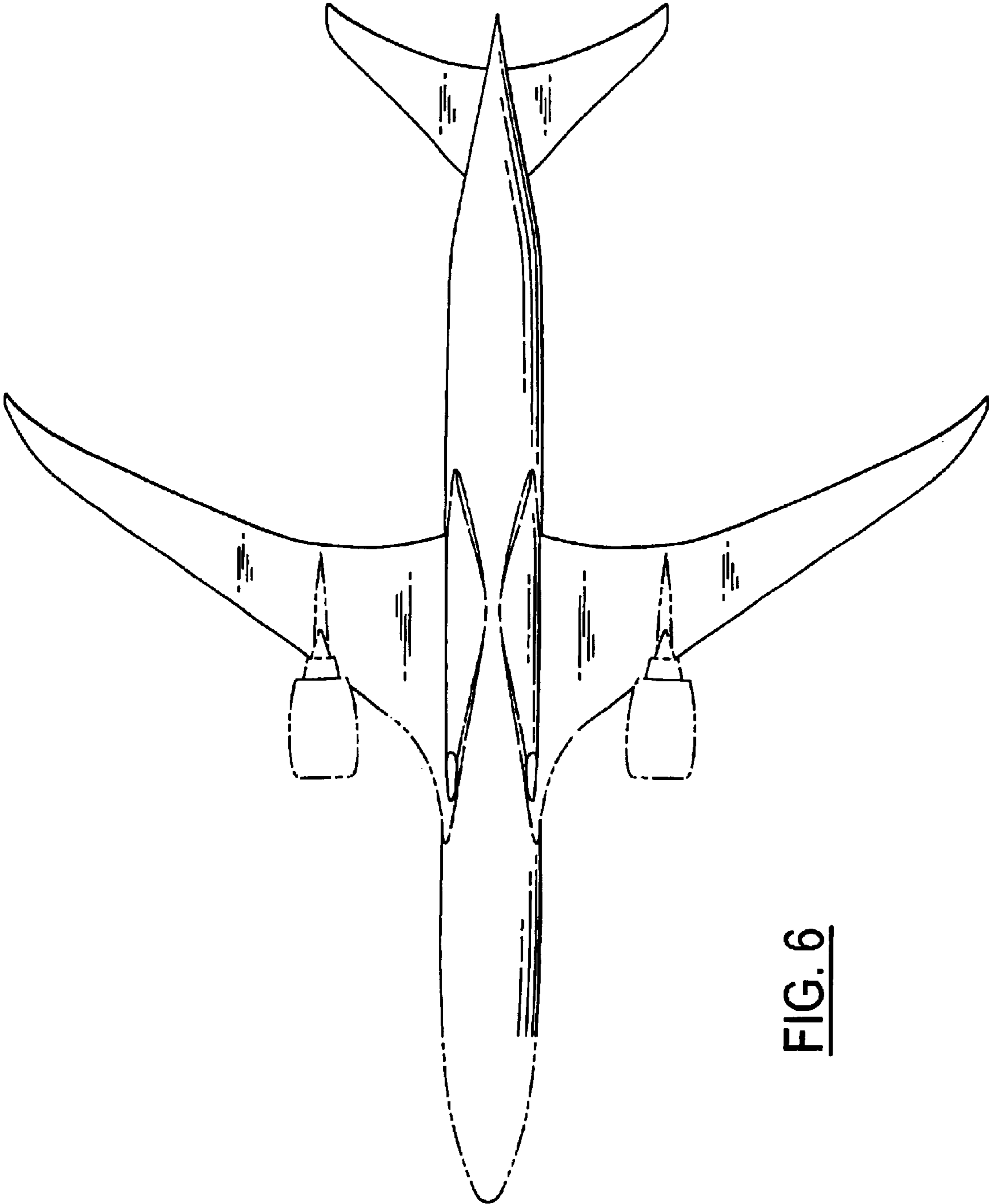

FIG. 6