

US00D500968S

(12) **United States Design Patent** (10) **Patent No.:** **US D500,968 S**
Metros et al. (45) **Date of Patent:** **** Jan. 18, 2005**

(54) **PICK UP TRUCK**

D488,405 S * 4/2004 Metros et al. D12/98

(75) Inventors: **Craig Metros**, Bloomfield, MI (US);
Patrick J. Schiavone, Birmingham, MI (US);
Tyler Jon Blake, Dearborn, MI (US);
Jeffery Nowak, Huntington, MI (US)

* cited by examiner

Primary Examiner—Melody N. Brown
(74) *Attorney, Agent, or Firm*—David S. Kelley

(73) Assignee: **Ford Global Technologies, LLC**,
Dearborn, MI (US)

(57) **CLAIM**

The ornamental design for a pick up truck, as shown and described.

(**) Term: **14 Years**

DESCRIPTION

(21) Appl. No.: **29/193,388**

FIG. 1 is a perspective view of a pick up truck in accordance with a preferred embodiment of the present invention; FIG. 2 is front view of the pick up truck of FIG. 1; FIG. 3 is a side view of the pick up truck of FIG. 1; FIG. 4 is a rear view of the pick up truck of FIG. 1; FIG. 5 is a top view of the pick up truck of FIG. 1; and, FIG. 6 is another perspective view of the pick up truck of FIG. 1.

(22) Filed: **Nov. 7, 2003**

(51) **LOC (7) Cl.** **12-08**

(52) **U.S. Cl.** **D12/98**

(58) **Field of Search** D12/98, 93; 296/183,
296/185, 186

The bottom view of the vehicle is not part of the claimed design. The sides of the vehicle are mirror images of one another. The broken lines, including for the tires, the headlamps, the tail lamps, the mirrors, the running boards, the handles and the grill illustrate the environment of the design and are not part of the claimed design.

(56) **References Cited**

U.S. PATENT DOCUMENTS

- D430,068 S * 8/2000 Castiglione et al. D12/98
- D456,311 S * 4/2002 Yamamoto et al. D12/86
- D466,451 S * 12/2002 Trostle et al. D12/98
- D478,844 S * 8/2003 Hayashi et al. D12/98
- D479,157 S * 9/2003 Hayashi et al. D12/98

1 Claim, 3 Drawing Sheets

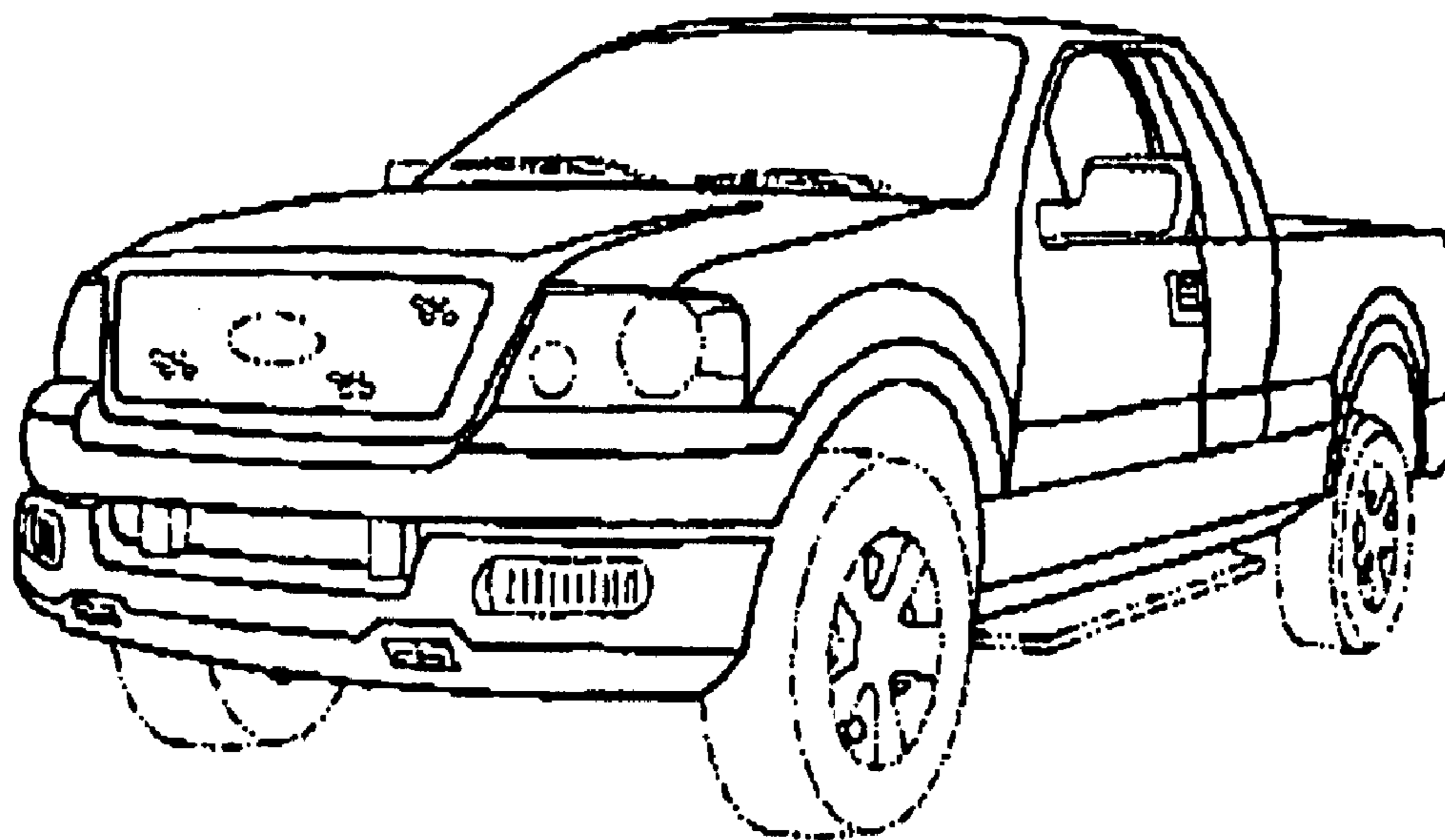

Figure 1

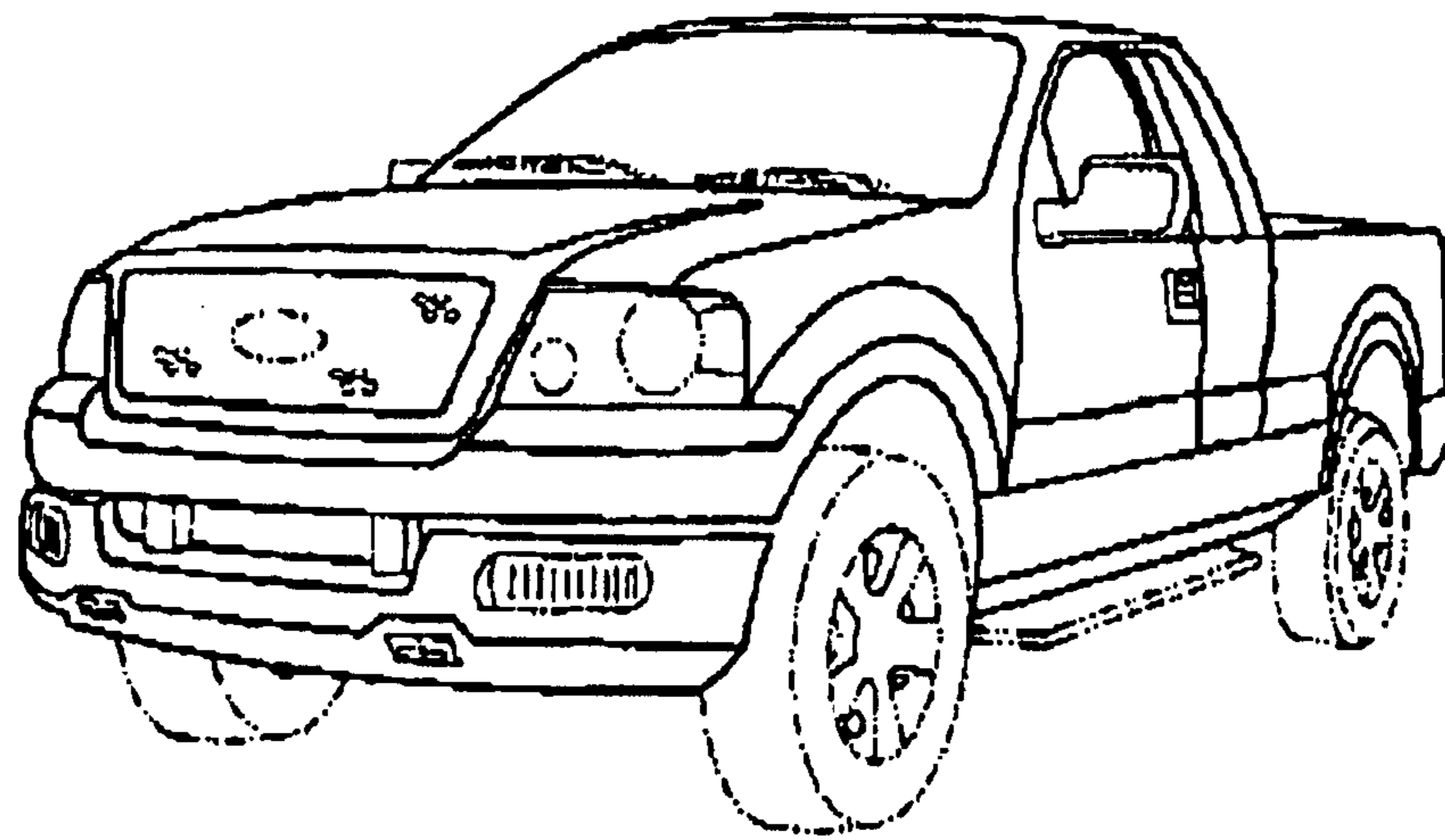

Figure 2

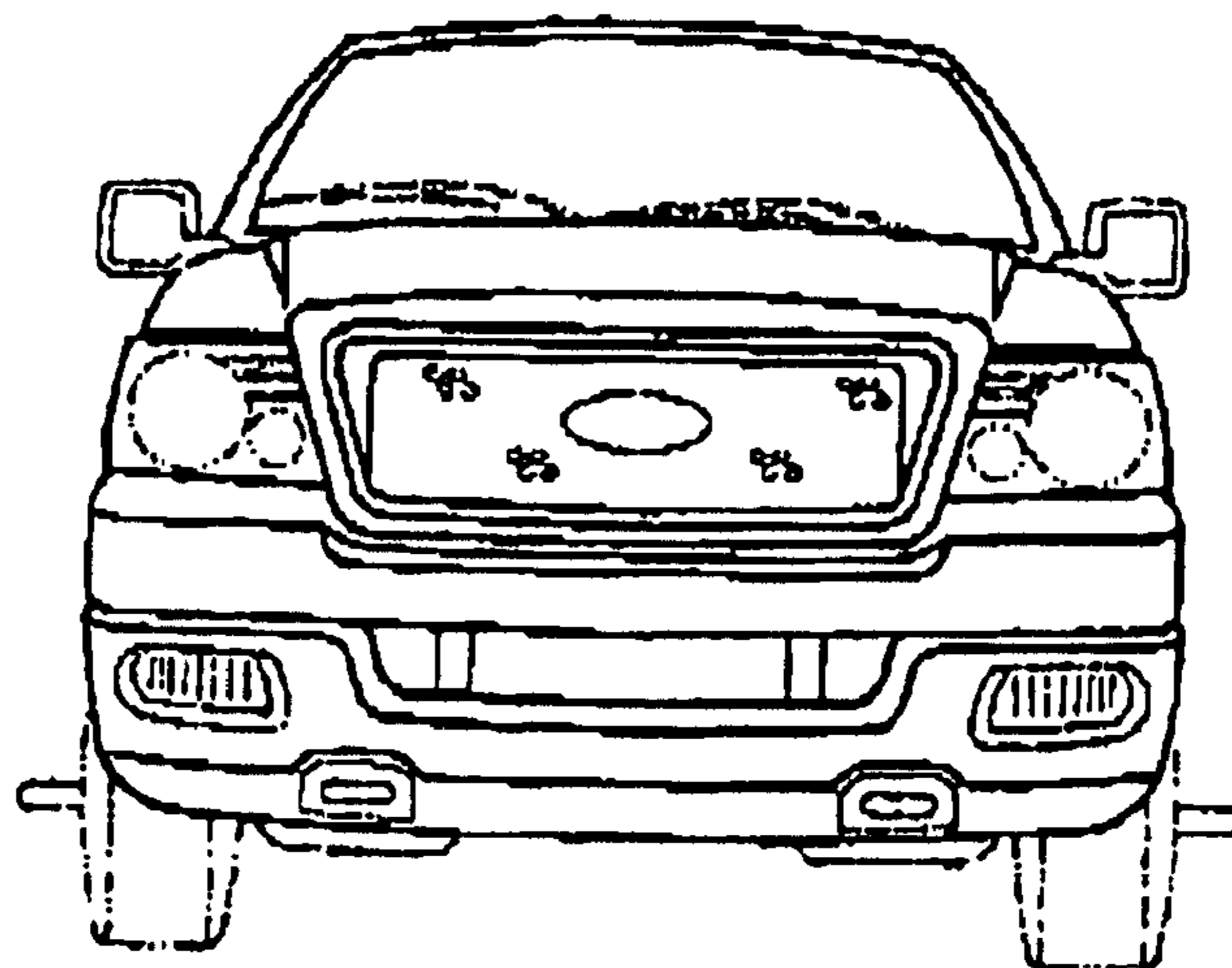

Figure 3

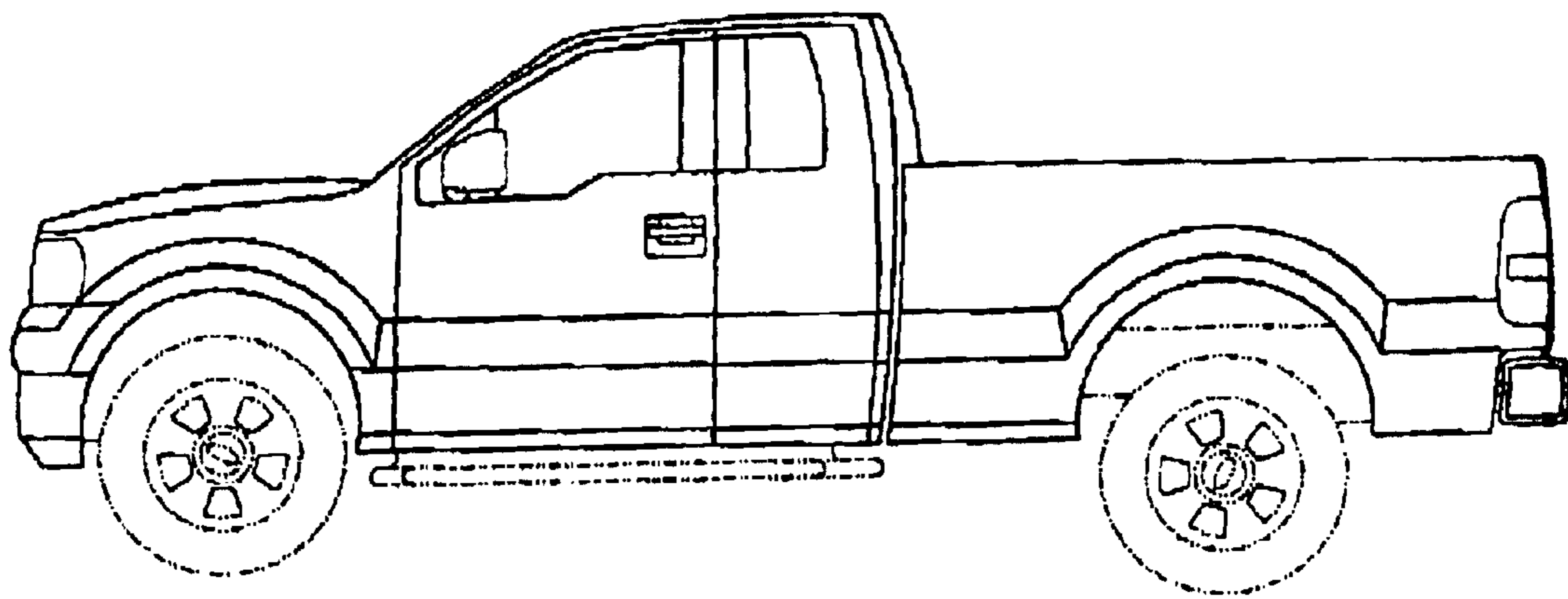

Figure 4

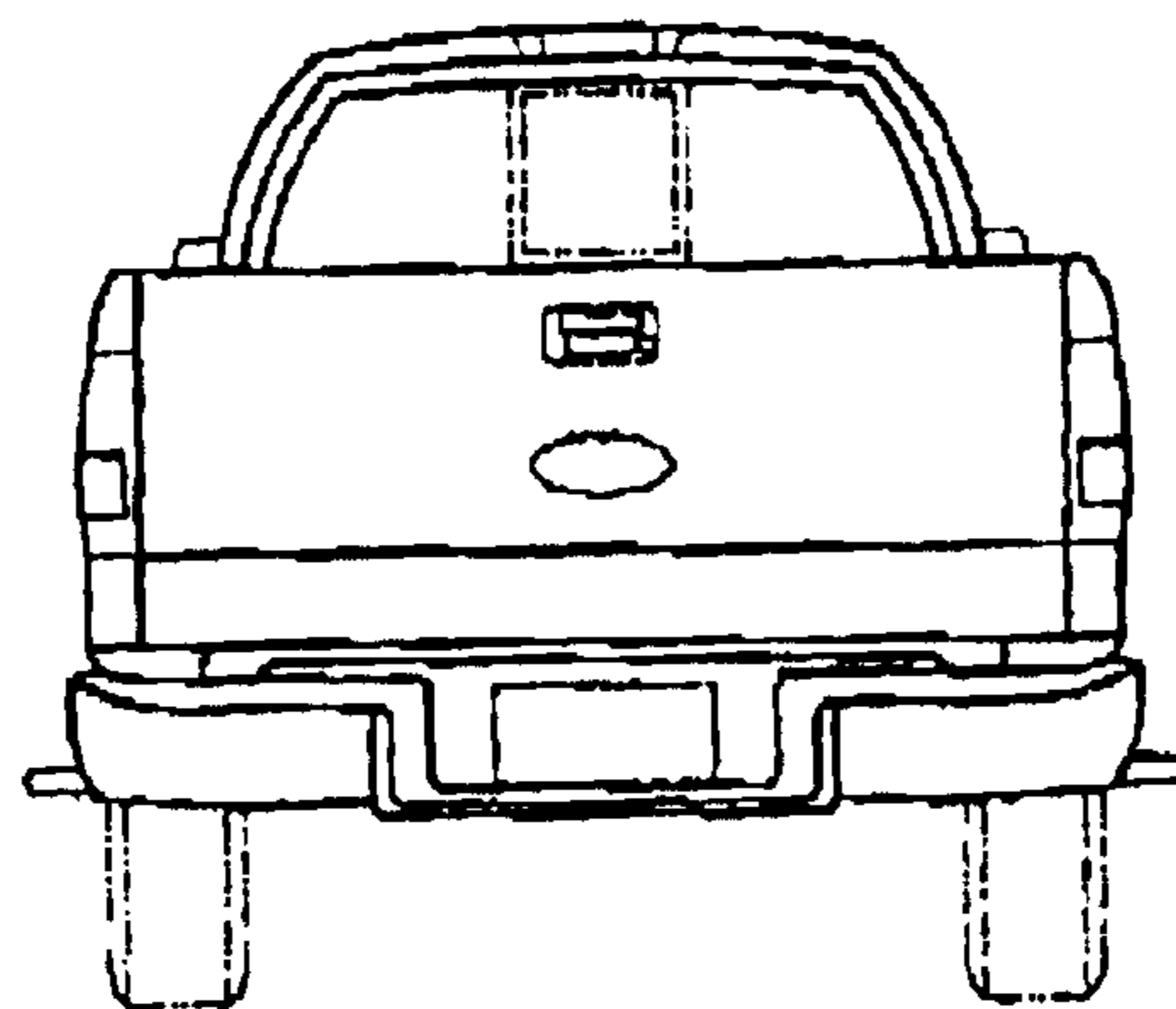

Figure 5

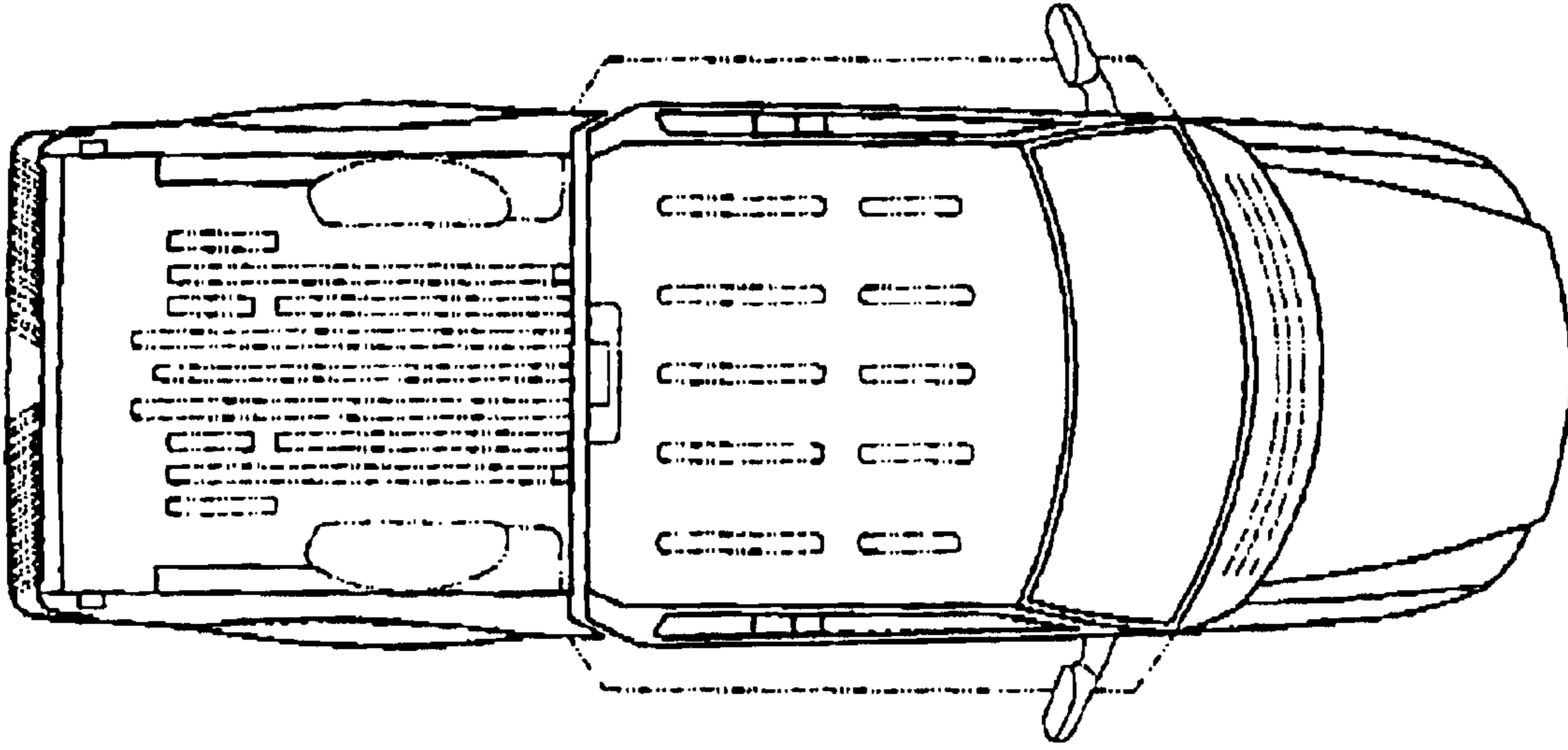

Figure 6

