

US00D500598S

(12) **United States Design Patent**
Ramos

(10) **Patent No.:** **US D500,598 S**
(45) **Date of Patent:** **** Jan. 11, 2005**

(54) **CONVERTIBLE STRAP FOR USE IN CONNECTION WITH SUPPORTING CONTAINERS**

6,390,345 B1 5/2002 Brown et al. 224/578
D489,182 S * 5/2004 Tilby et al. D3/327
2003/0106914 A1 * 6/2003 Gann 224/150

(75) Inventor: **Jaime Ramos**, Northridge, CA (US)

* cited by examiner

(73) Assignee: **Pacific Tides International, Inc.**, Los Angeles, CA (US)

Primary Examiner—Catherine R. Oliver
(74) *Attorney, Agent, or Firm*—John F. Sicotte

(**) Term: **14 Years**

(57) **CLAIM**

(21) Appl. No.: **29/187,076**

The ornamental design for convertible strap for use in connection with supporting containers, as shown and described.

(22) Filed: **Jul. 28, 2003**

DESCRIPTION

(51) **LOC (7) Cl.** **03-01**

FIG. 1 is a side elevational view of the convertible strap showing my new design.

(52) **U.S. Cl.** **D3/327**

FIG. 2 is a top plan view of the convertible strap of FIG. 1. FIG. 3 is a bottom plan view of the convertible strap of FIG. 1.

(58) **Field of Search** D3/327, 215, 221–222, D3/318–320, 232–234; 224/149–150, 250, 257–259, 264, 578–579, 910–913; 294/154, 149, 150, 151

FIG. 4 is a top plan view of the left hand fastener of the convertible strap of FIG. 1.

(56) **References Cited**

U.S. PATENT DOCUMENTS

| | | | | |
|--------------|-----------|-----------|-------|---------|
| 2,394,782 A | 2/1946 | Kalske | | 294/141 |
| D158,897 S | 6/1950 | Ruml, Jr. | | 190/115 |
| 3,259,285 A | 7/1966 | Bush | | 294/154 |
| 3,790,049 A | 2/1974 | Bohanec | | 224/139 |
| 4,153,092 A | 5/1979 | Haslam | | 150/108 |
| 4,763,763 A | 8/1988 | Sadow | | 190/115 |
| D304,882 S | * 12/1989 | Kawaguchi | | D3/327 |
| 5,119,910 A | 6/1992 | Heggeland | | 190/116 |
| 5,388,743 A | * 2/1995 | Silagy | | 224/910 |
| D367,761 S | * 3/1996 | Knutson | | D3/327 |
| D386,310 S | * 11/1997 | Smith | | D3/327 |
| 5,950,893 A | 9/1999 | Heggeland | | 224/578 |
| 6,296,165 B1 | 10/2001 | Mears | | D3/233 |
| D457,725 S | * 5/2002 | Parsons | | D3/327 |

FIG. 5 is a top plan view of the right hand fastener of the convertible strap of FIG. 1.

FIG. 6 is a top, front left side perspective view of the convertible strap of FIG. 1 shown in the shoulder strap mode.

FIG. 7 is a top, front left side perspective view of the convertible strap of FIG. 1 shown being collapsed into the handle mode; and,

FIG. 8 is a top, front left side perspective view of the convertible strap of FIG. 1 shown completely collapsed into the handle mode.

The broken line showing of environment in the drawings is for illustrative purposes only and forms no part of the claimed design.

1 Claim, 2 Drawing Sheets





FIG. 1

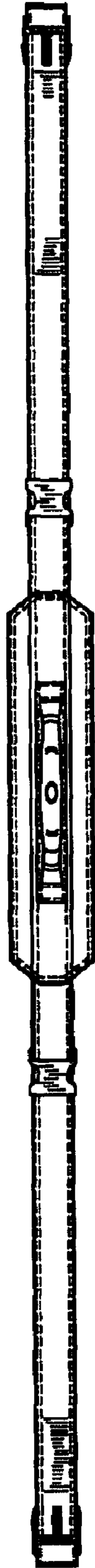

FIG. 2



FIG. 3



FIG. 4



FIG. 5

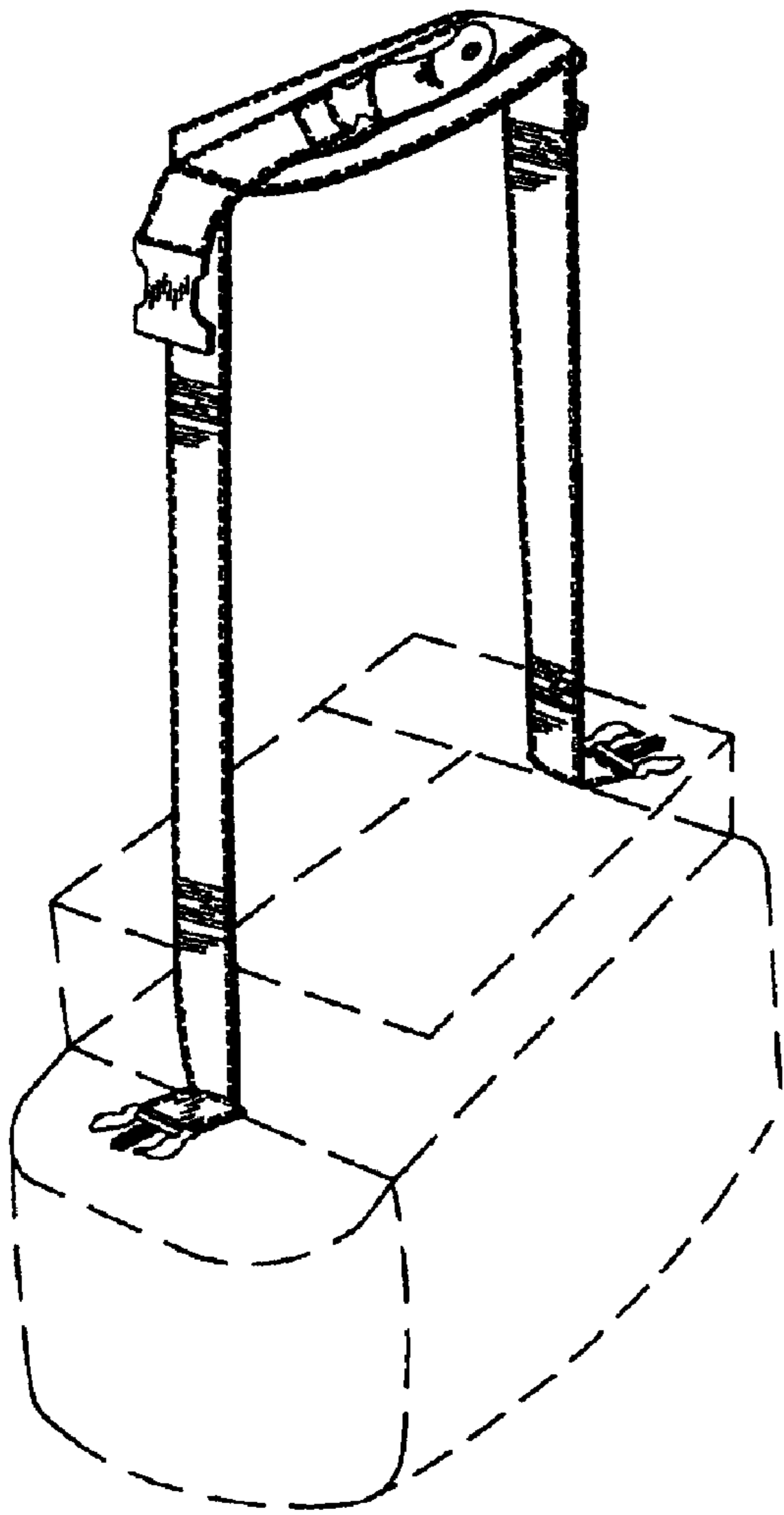

FIG. 6

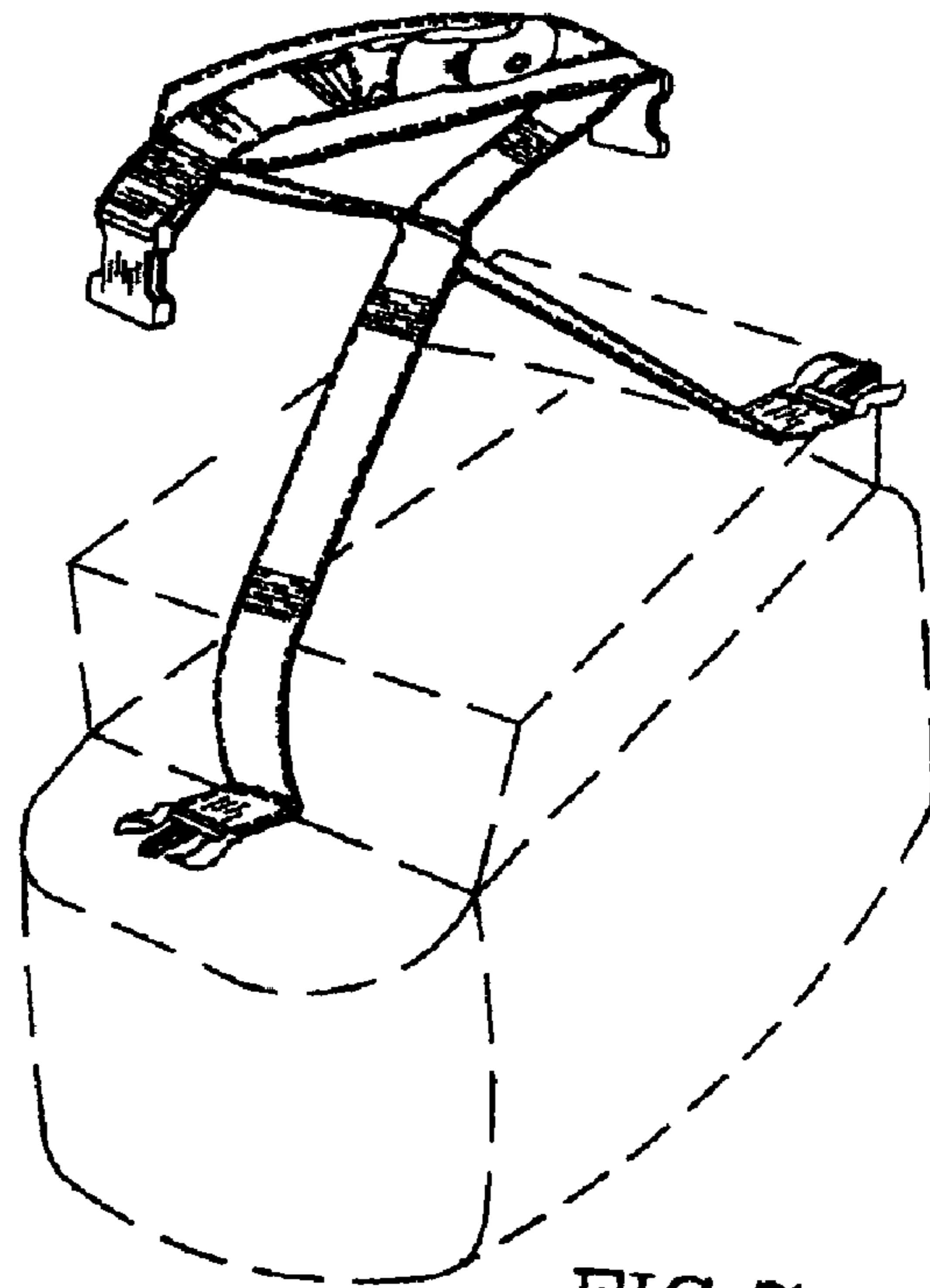

FIG. 7

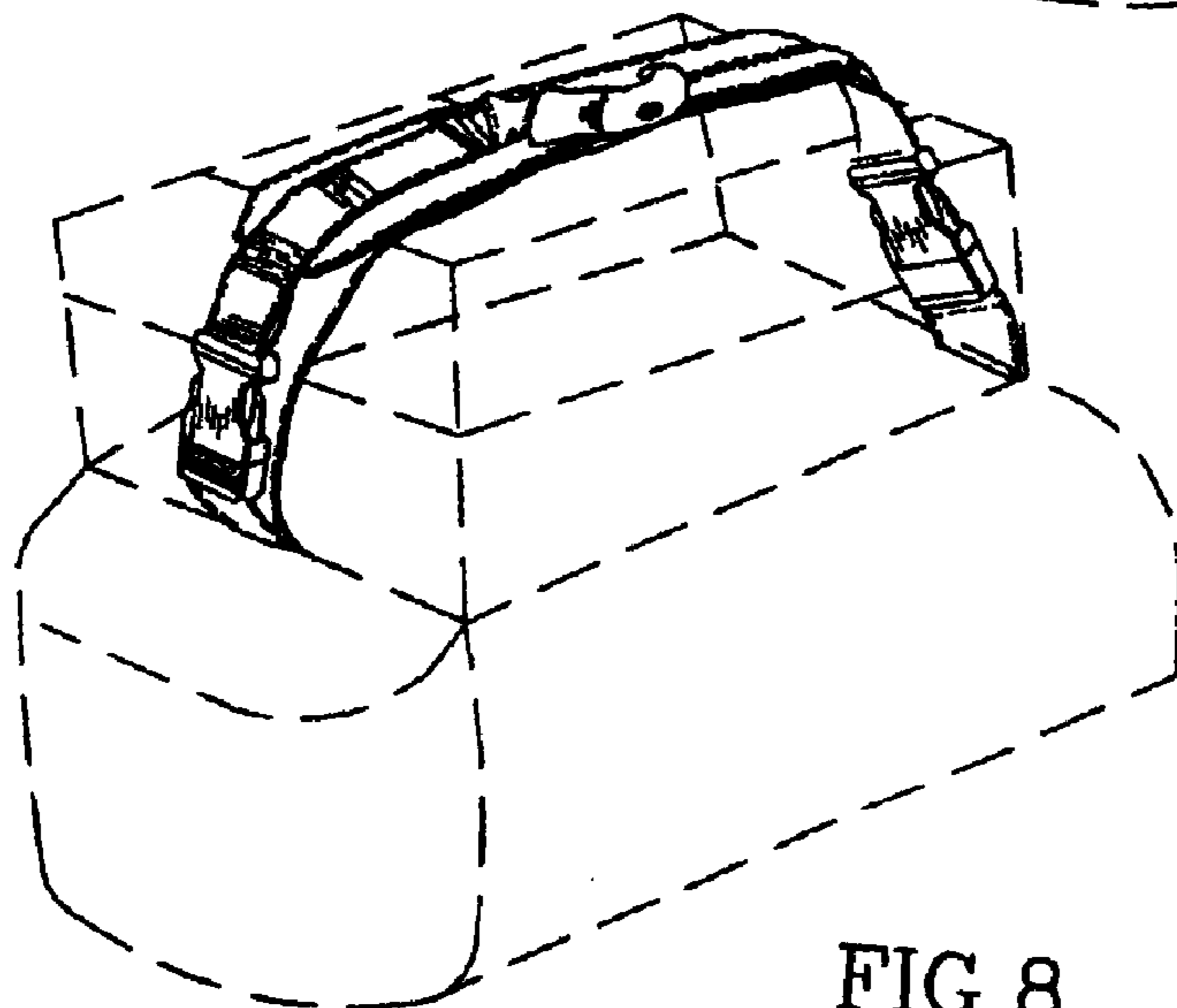

FIG. 8