

US00D500282S

(12) **United States Design Patent**  
**Aruga et al.**

(10) **Patent No.:** **US D500,282 S**  
(45) **Date of Patent:** **\*\* Dec. 28, 2004**

(54) **AIRCRAFT**

(75) **Inventors:** **Hiroyasu Aruga**, Nagoya (JP); **Hisao Arai**, Nagoya (JP); **Kei Kitadate**, Nagoya (JP); **Takafumi Nakatani**, Nagoya (JP); **Kengo Hayashi**, Nagoya (JP); **Yukihiko Nakata**, Nagoya (JP); **Yasushi Ando**, Nagoya (JP); **Naoki Futatsudera**, Nagoya (JP); **Shinichiro Taura**, Nagoya (JP); **Yuugo Fukuhara**, Nagoya (JP); **Kenji Inaba**, Nagoya (JP); **Kazuhide Shinoda**, Nagoya (JP); **Yuichi Shimbo**, Nagoya (JP)

(73) **Assignee:** **Mitsubishi Heavy Industries, Ltd.**, Tokyo (JP)

(\*\*) **Term:** **14 Years**

(21) **Appl. No.:** **29/204,221**

(22) **Filed:** **Apr. 27, 2004**

(30) **Foreign Application Priority Data**

Oct. 27, 2003 (JP) ..... 2003-031658

(51) **LOC (7) Cl.** ..... **12-99**

(52) **U.S. Cl.** ..... **D12/319**

(58) **Field of Search** ..... D12/319-345;  
244/12.5, 13, 15, 55, 65

(56) **References Cited**

**U.S. PATENT DOCUMENTS**

D418,105 S \* 12/1999 Margaritoff ..... D12/319  
D421,955 S \* 3/2000 Birrenbach ..... D12/319  
D491,875 S \* 6/2004 Eatkins et al. .... D12/319

\* cited by examiner

*Primary Examiner*—Marcus A. Jackson  
(74) *Attorney, Agent, or Firm*—Wenderoth, Lind & Ponack, L.L.P.

(57) **CLAIM**

The ornamental design for aircraft, as shown and described.

**DESCRIPTION**

FIG. 1 is a front view of an aircraft according to the present design;  
FIG. 2 is a rear view of the aircraft;  
FIG. 3 is a right side view of the aircraft;  
FIG. 4 is a left side view of the aircraft;  
FIG. 5 is a plan view of the aircraft;  
FIG. 6 is a bottom view of the aircraft;  
FIG. 7 is a front perspective view of the aircraft; and,  
FIG. 8 is a rear perspective view of the aircraft.  
Features shown by dashed lines are not considered part of the claimed design.

**1 Claim, 4 Drawing Sheets**

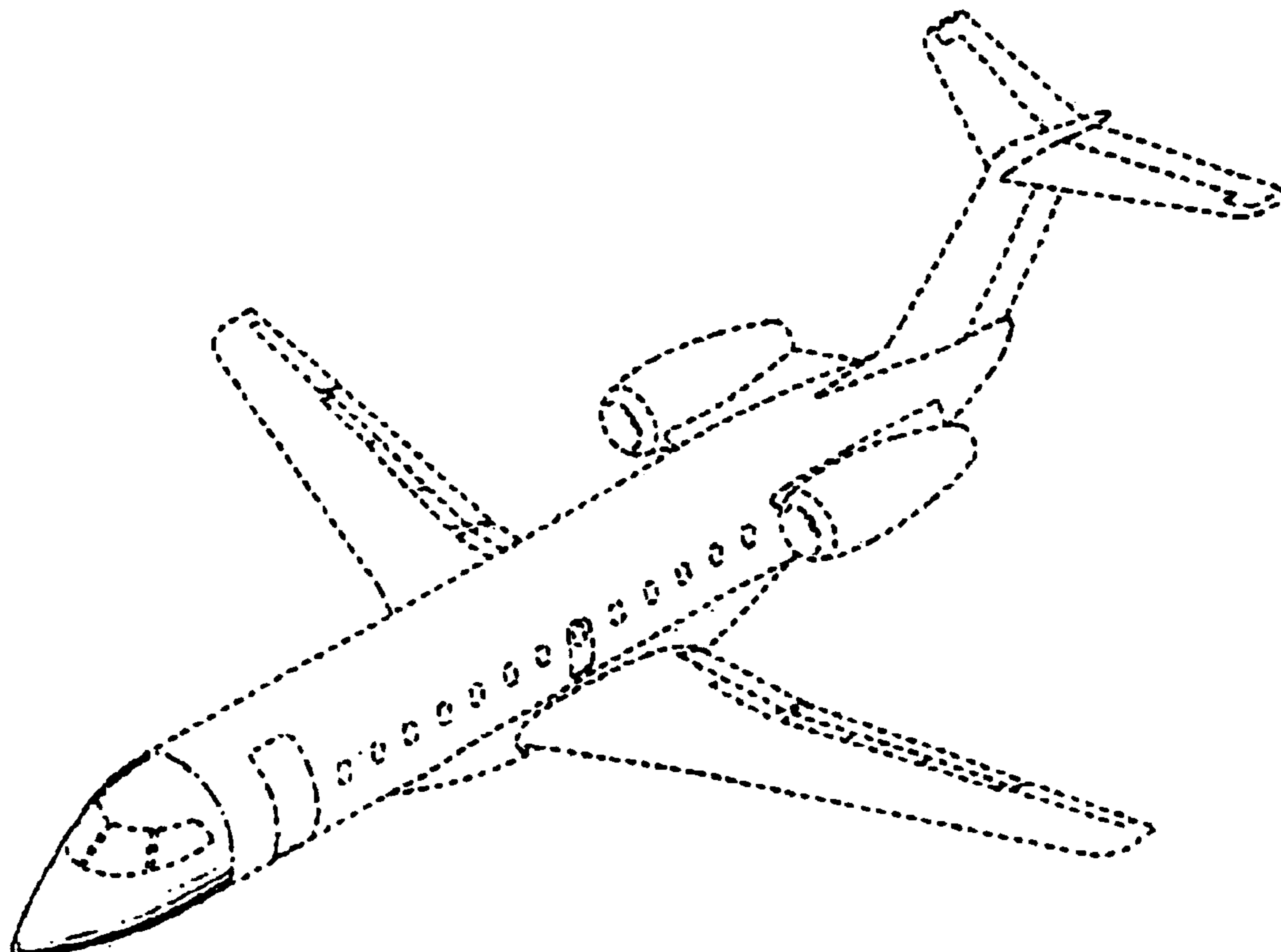

FIGURE 1

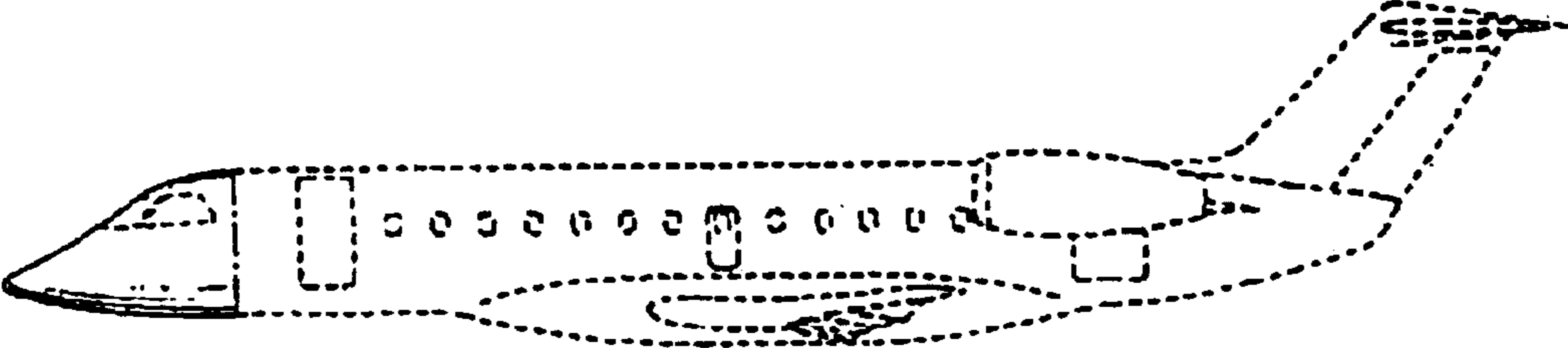

FIGURE 2

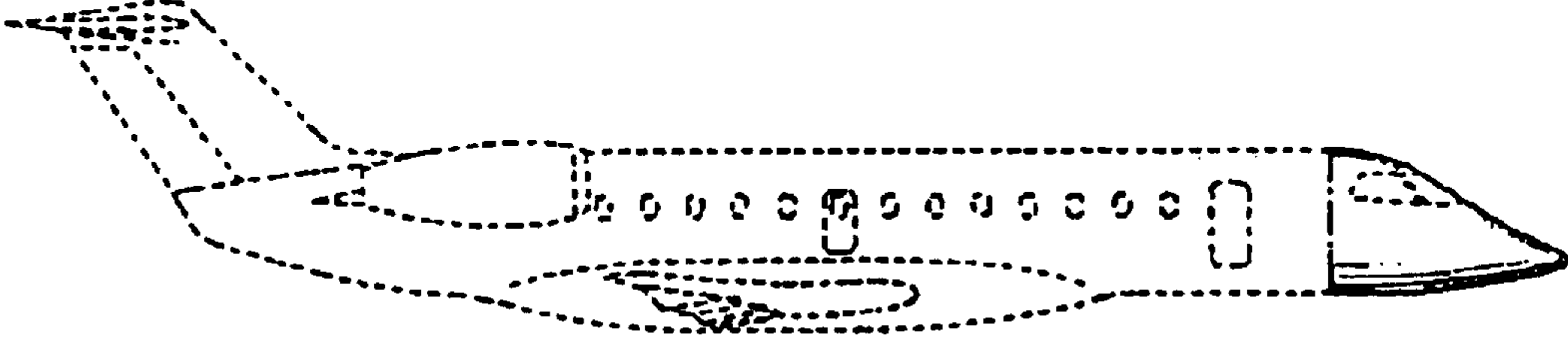

FIGURE 3

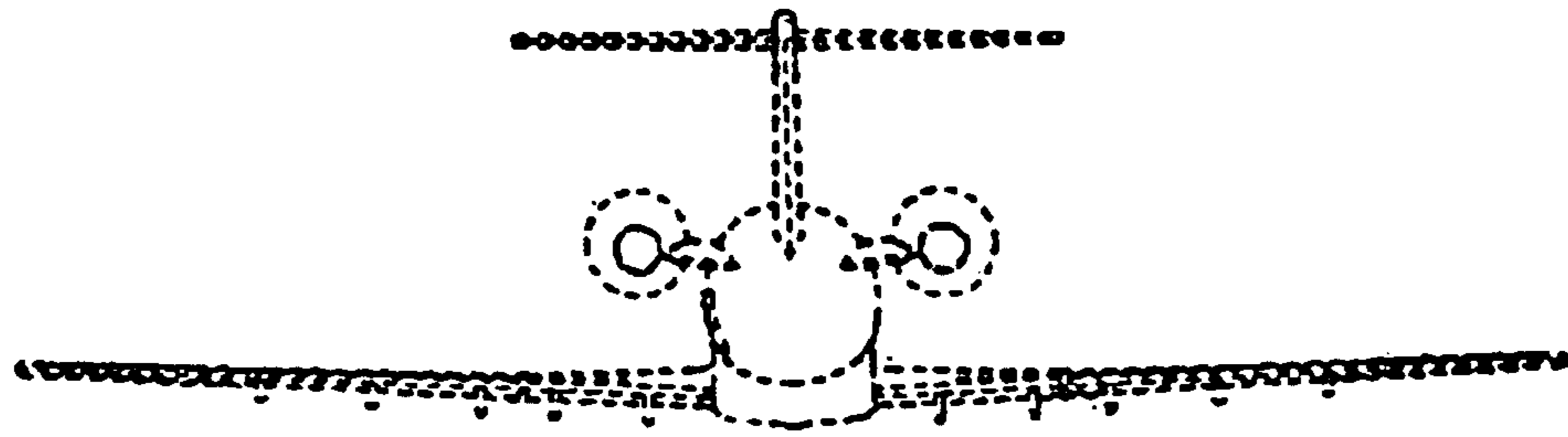

FIGURE 4

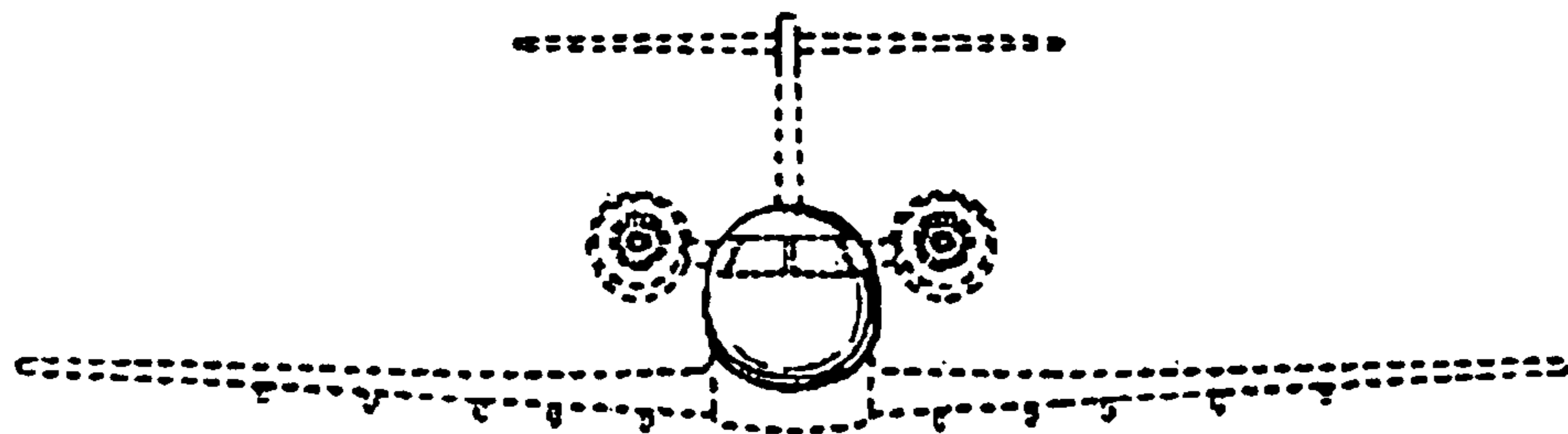

FIGURE 5

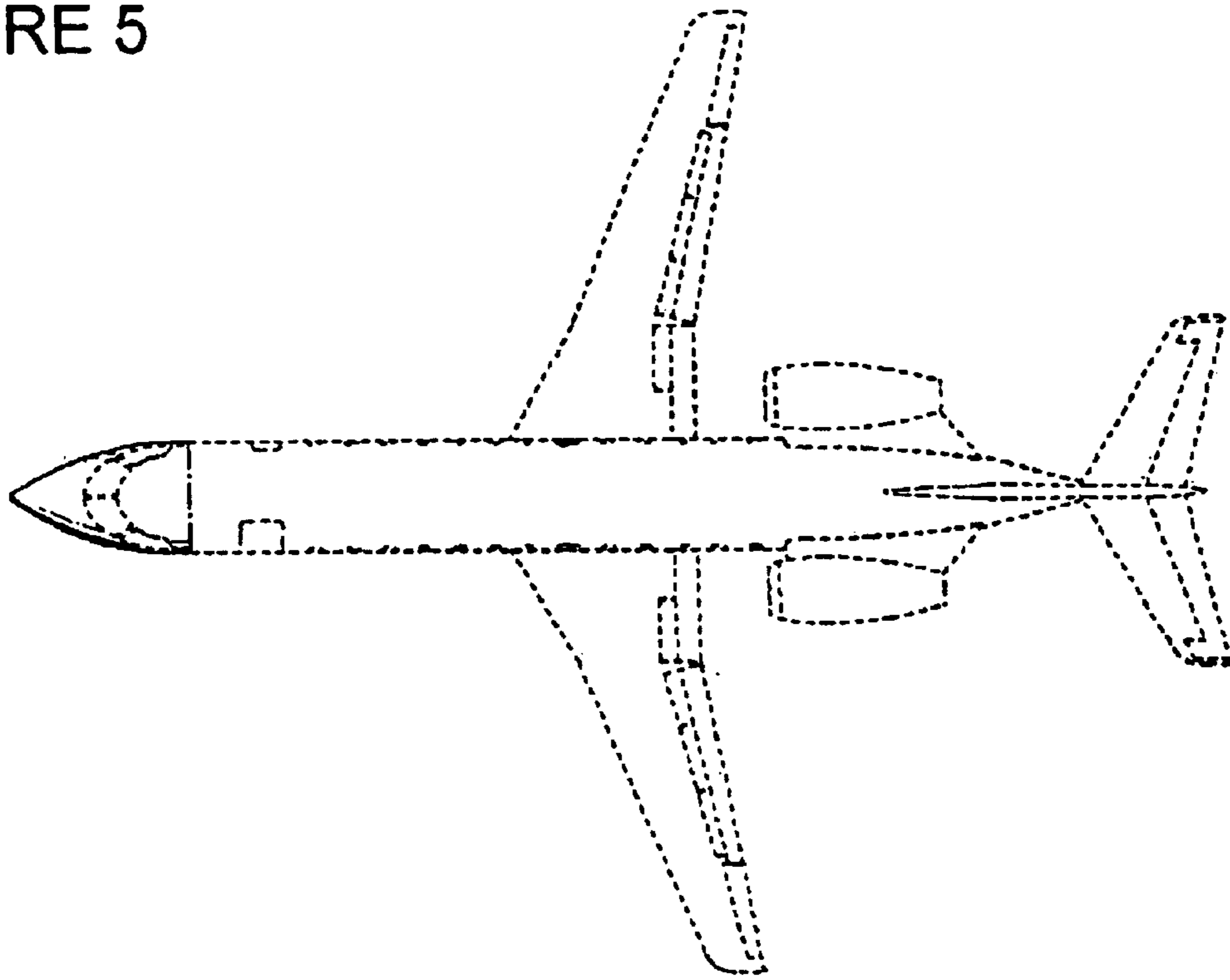

FIGURE 6

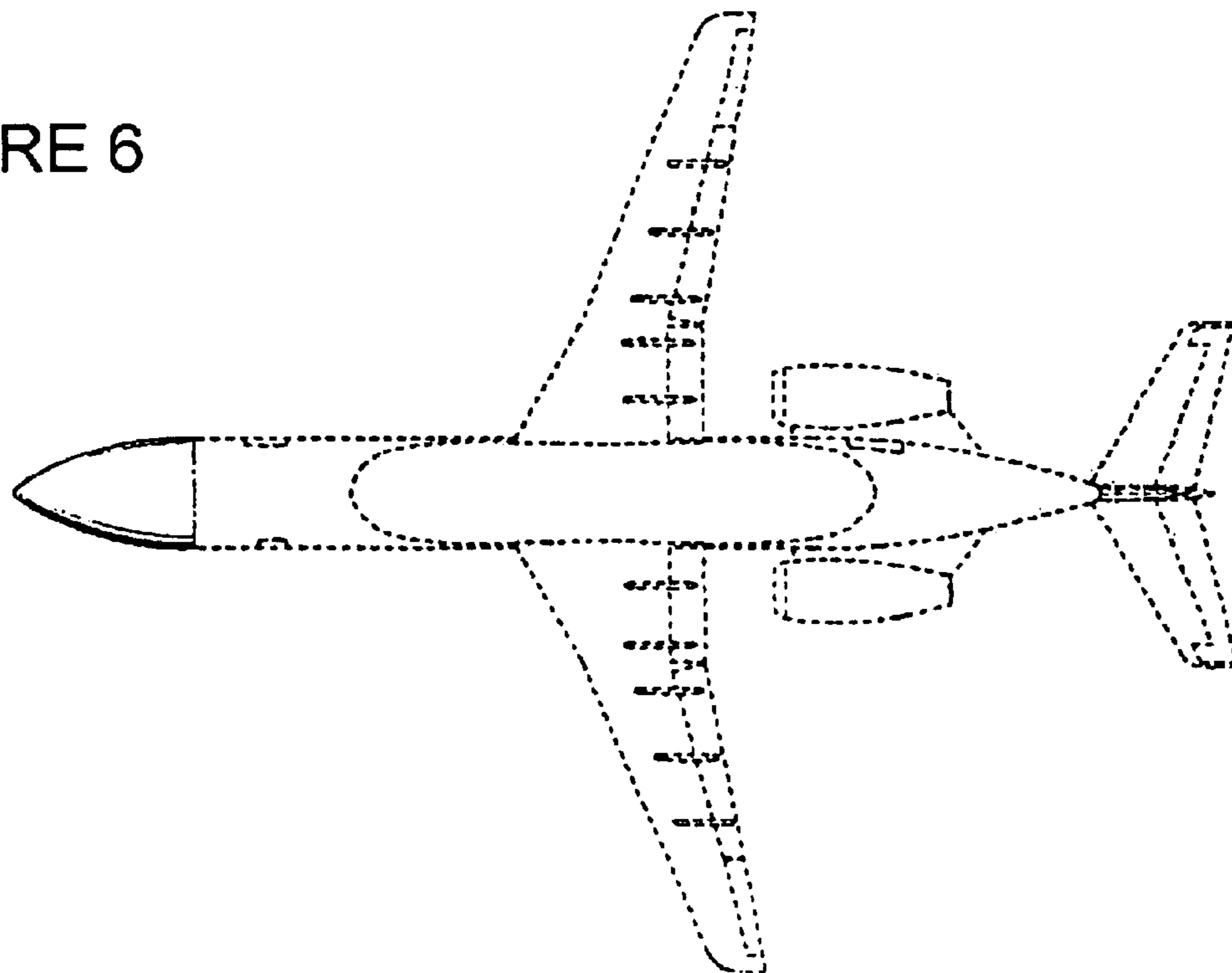

FIGURE 7

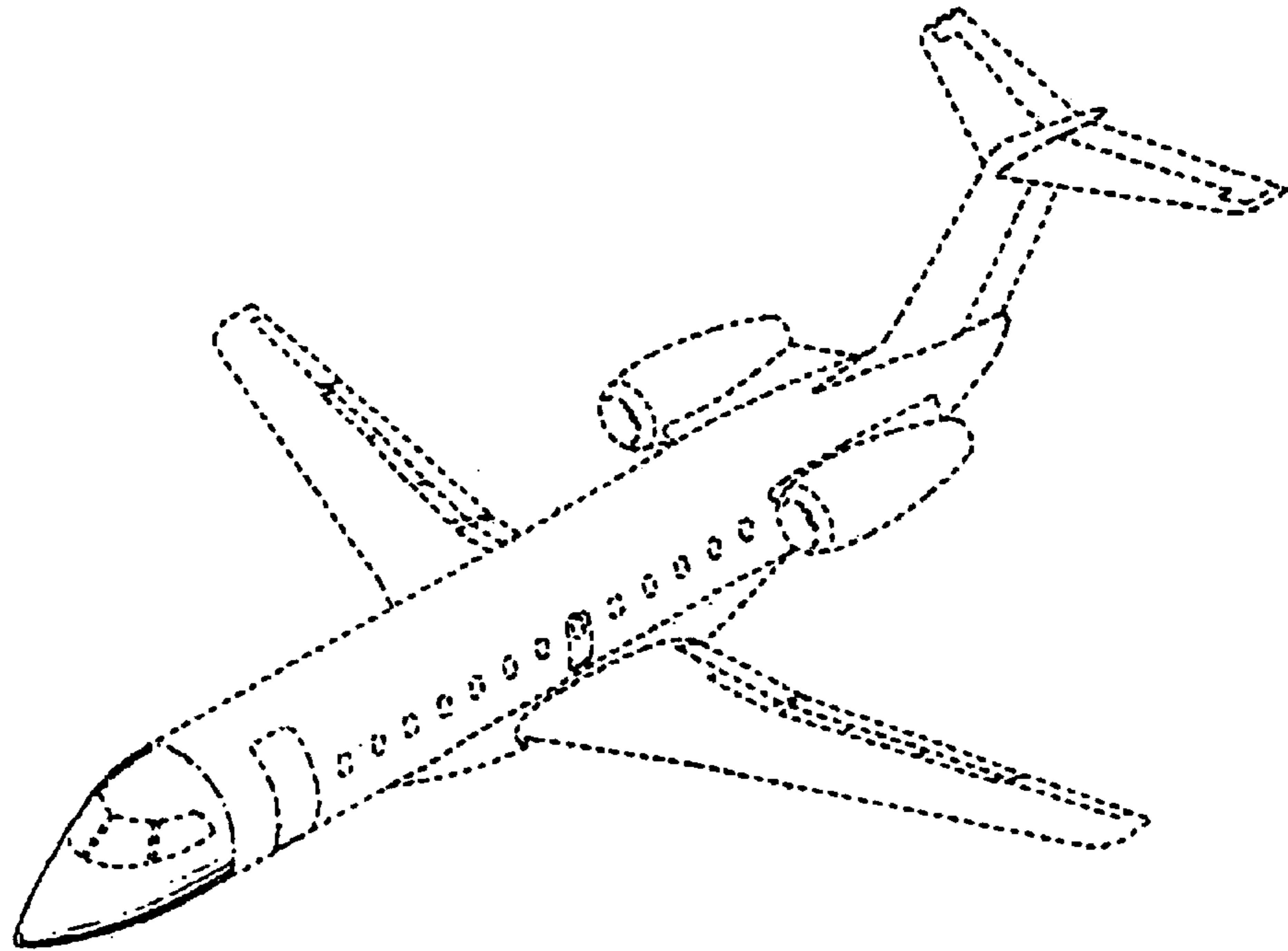

FIGURE 8

