

US00D500281S

(12) **United States Design Patent**
Aruga et al.

(10) **Patent No.: US D500,281 S**

(45) **Date of Patent: ** Dec. 28, 2004**

(54) **AIRCRAFT**

D469,054 S * 1/2003 Fujino D12/319
D491,875 S * 6/2004 Eatkins et al. D12/319

(75) Inventors: **Hiroyasu Aruga**, Nagoya (JP); **Hisao Arai**, Nagoya (JP); **Kei Kitadate**, Nagoya (JP); **Takafumi Nakatani**, Nagoya (JP); **Kengo Hayashi**, Nagoya (JP); **Yukihiko Nakata**, Nagoya (JP); **Yasushi Ando**, Nagoya (JP); **Naoki Futatsudera**, Nagoya (JP); **Shinichiro Taura**, Nagoya (JP); **Yuugo Fukuhara**, Nagoya (JP); **Kenji Inaba**, Nagoya (JP); **Kazuhide Shinoda**, Nagoya (JP); **Yuichi Shimbo**, Nagoya (JP)

* cited by examiner

Primary Examiner—Marcus A. Jackson
(74) *Attorney, Agent, or Firm*—Wenderoth, Lind & Ponack, L.L.P.

(73) Assignee: **Mitsubishi Heavy Industries, Ltd.**, Tokyo (JP)

(**) Term: **14 Years**

(21) Appl. No.: **29/204,220**

(22) Filed: **Apr. 27, 2004**

(30) **Foreign Application Priority Data**

Oct. 27, 2003 (JP) 2003-031660

(51) **LOC (7) Cl.** **12-99**

(52) **U.S. Cl.** **D12/319**

(58) **Field of Search** D12/319-345;
244/12.5, 13, 15, 55, 65

(56) **References Cited**

U.S. PATENT DOCUMENTS

D418,105 S * 12/1999 Margaritoff D12/319
D451,879 S * 12/2001 Fraser D12/319

(57) **CLAIM**

The ornamental design for aircraft, as shown and described.

DESCRIPTION

FIG. 1 is a front view of an aircraft according to the present design;
FIG. 2 is a rear view of the aircraft;
FIG. 3 is a right side view of the aircraft;
FIG. 4 is a left side view of the aircraft;
FIG. 5 is a plan view of the aircraft;
FIG. 6 is a bottom view of the aircraft;
FIG. 7 is a front perspective view of the aircraft;
FIG. 8 is a rear perspective view of the aircraft;
FIG. 9 is a referential front view showing transparent portions of the aircraft;
FIG. 10 is a referential rear view showing transparent portions of the aircraft;
FIG. 11 is a referential plan view showing transparent portions of the aircraft;
FIG. 12 is a referential left side view showing transparent portions of the aircraft;
FIG. 13 is a referential front perspective view showing transparent portions of the aircraft; and,
FIG. 14 is a referential rear perspective view showing transparent portions of the aircraft.

1 Claim, 7 Drawing Sheets

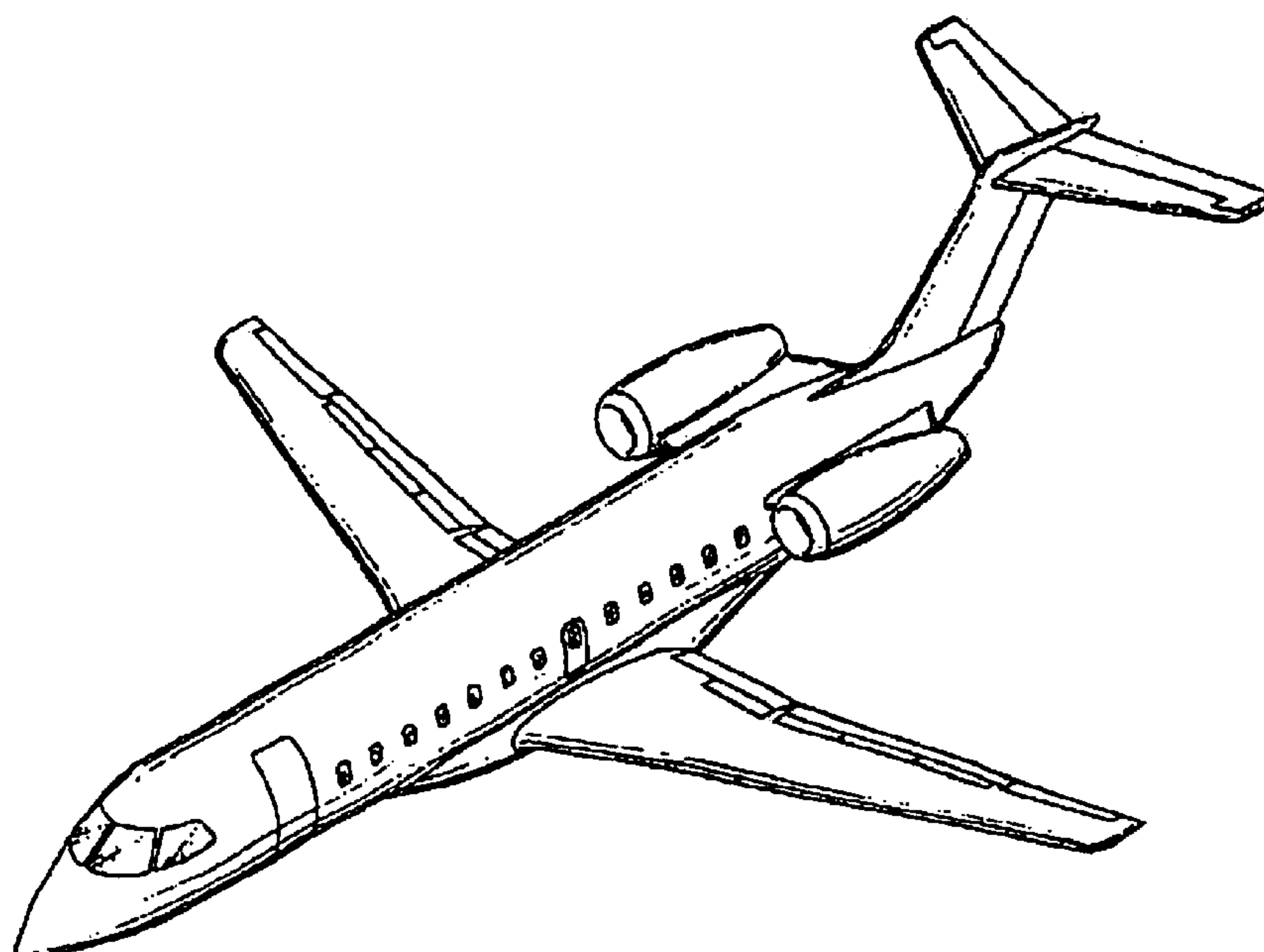

FIGURE 1

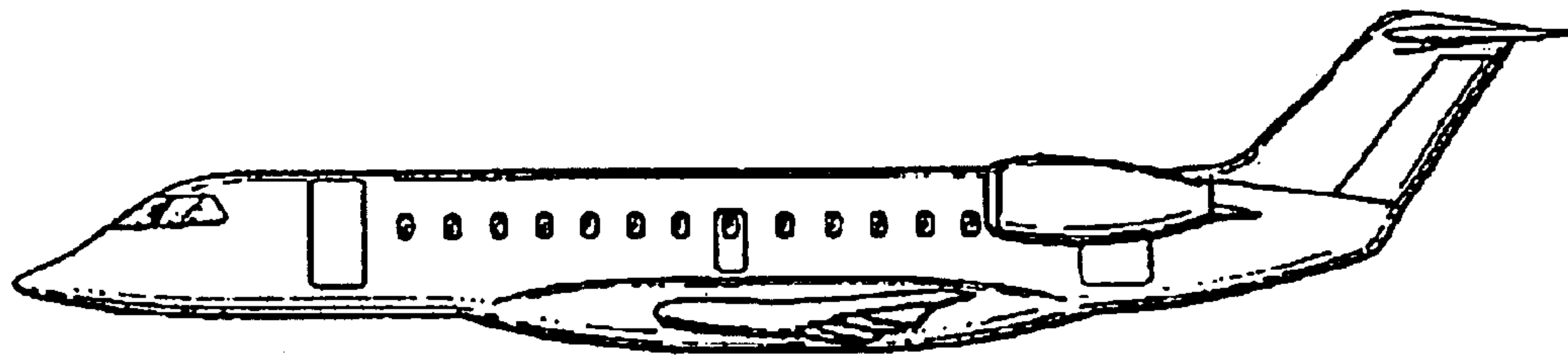

FIGURE 2

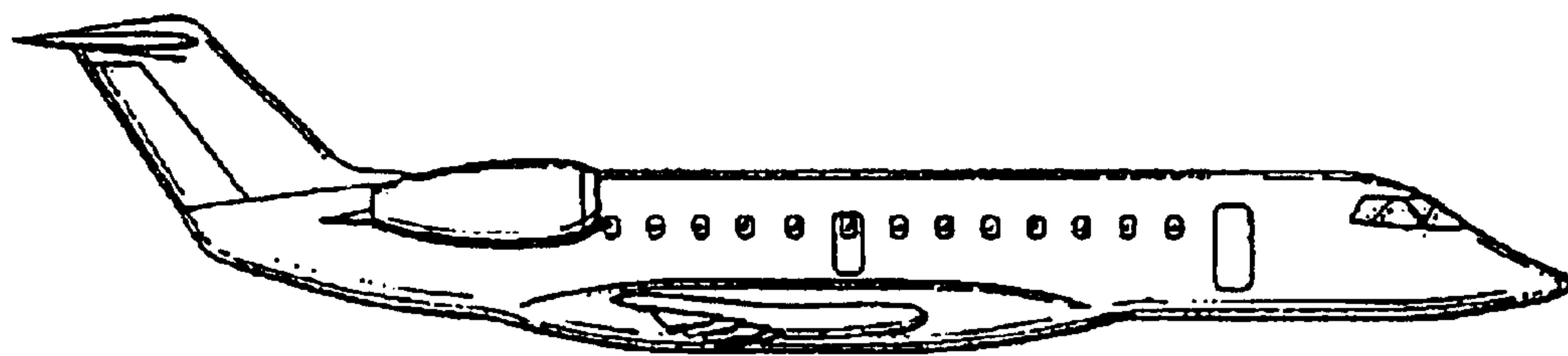

FIGURE 3

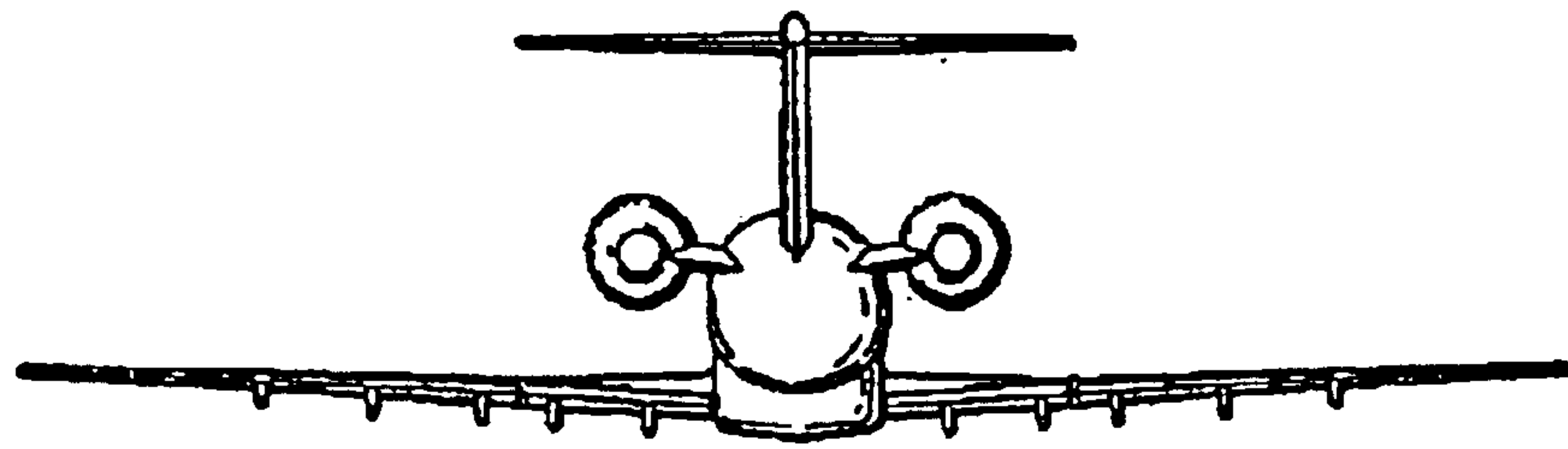

FIGURE 4

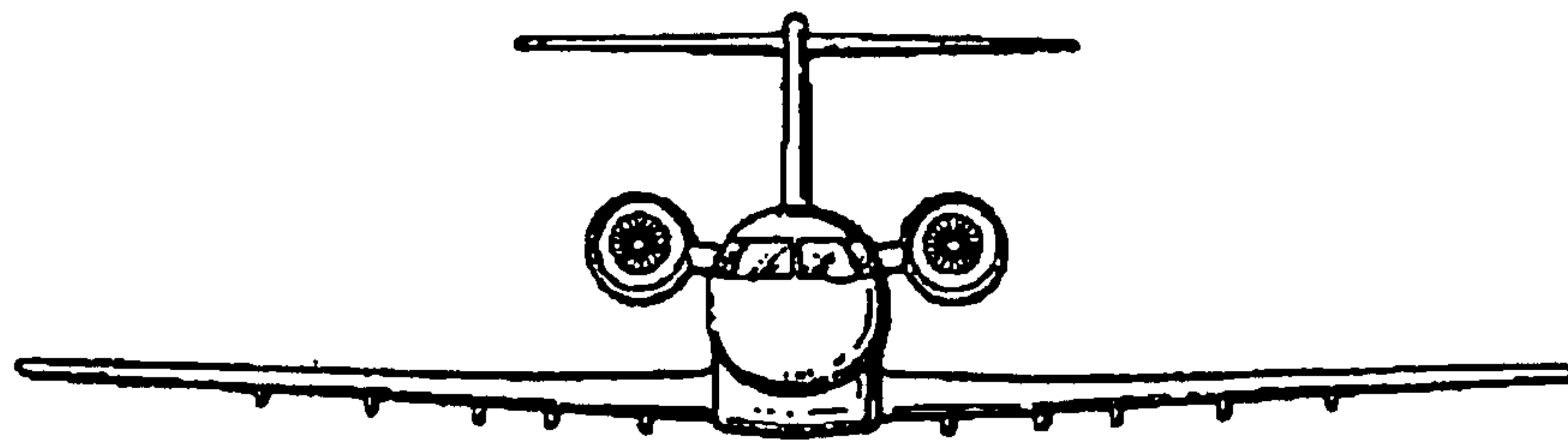

FIGURE 5

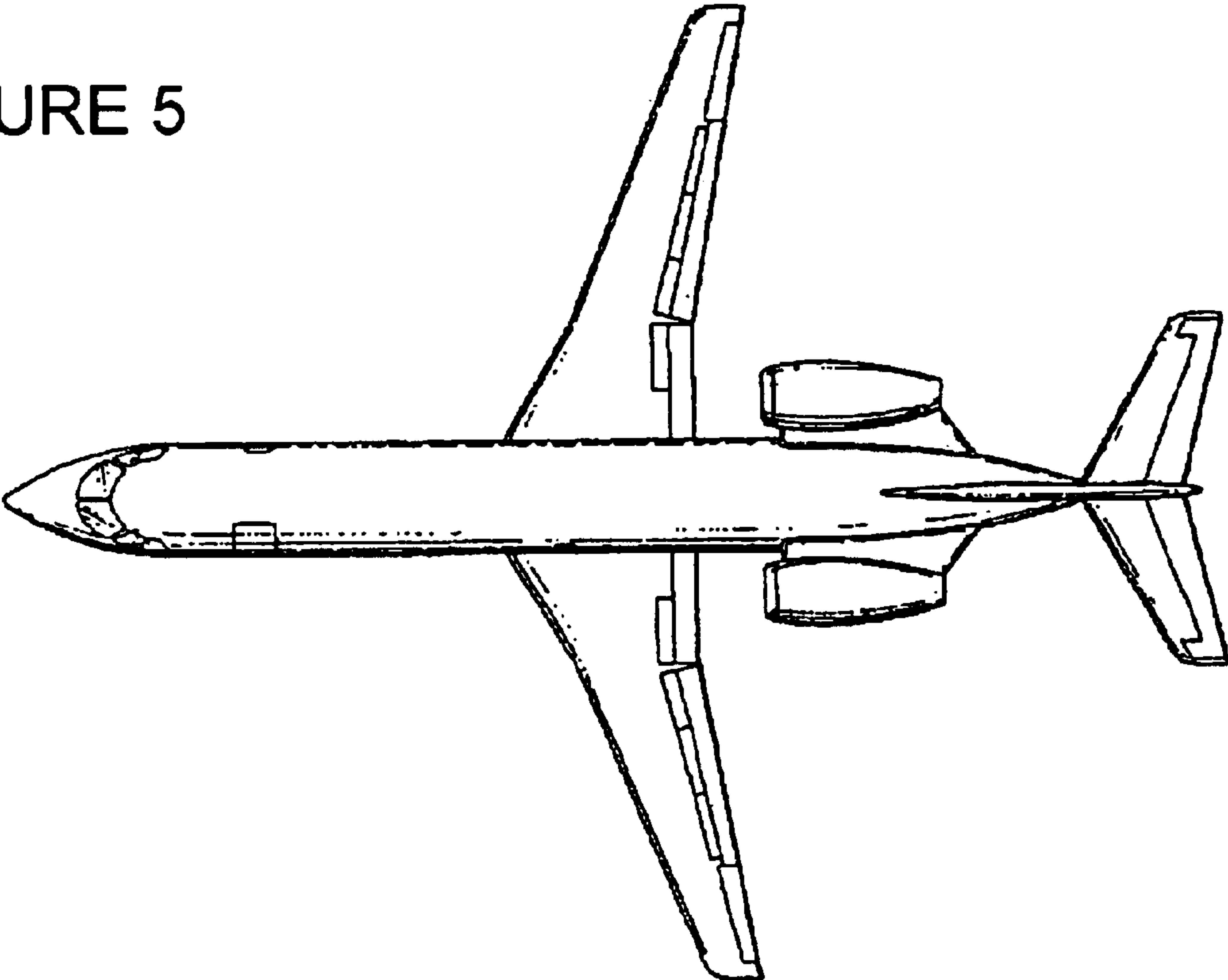

FIGURE 6

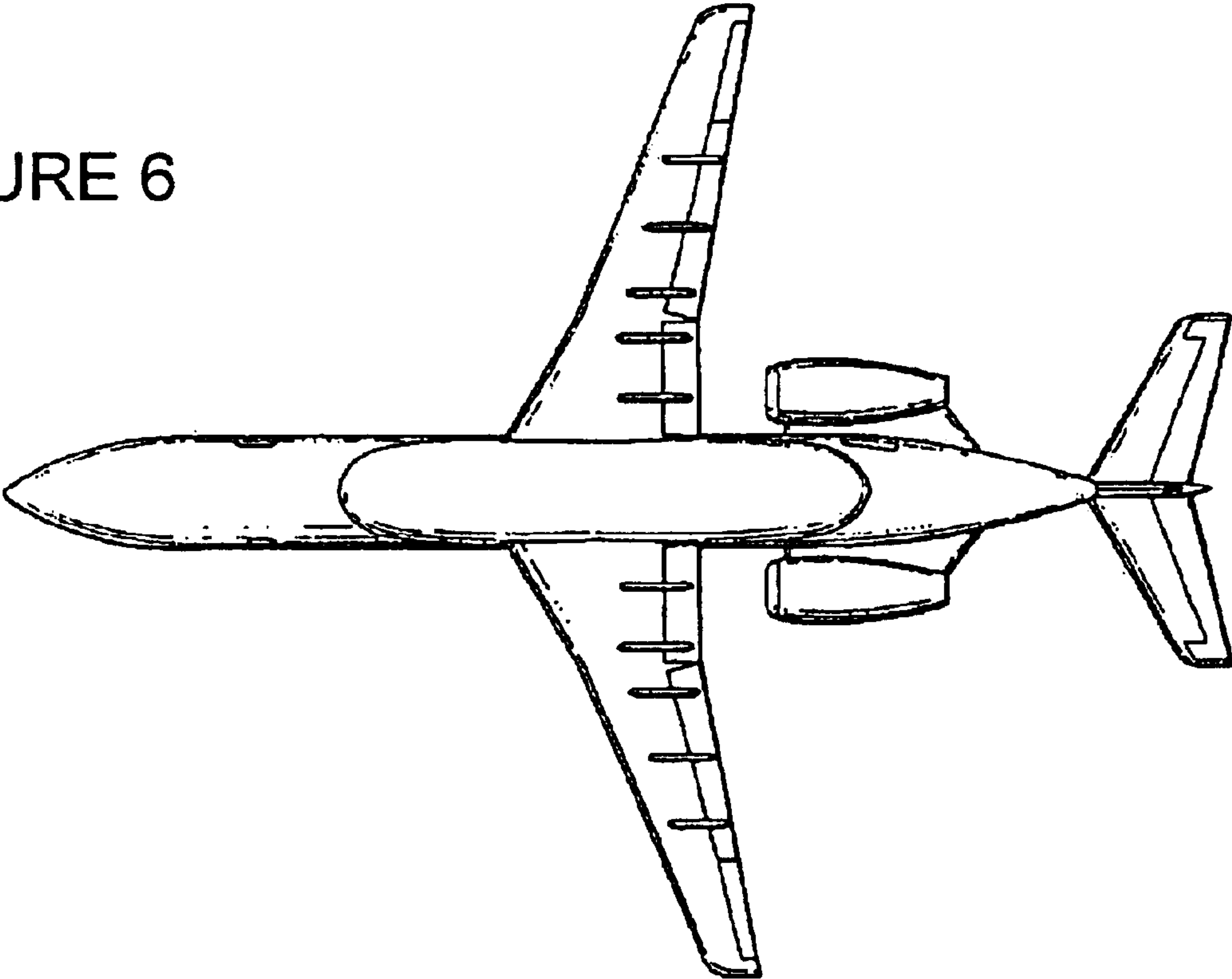

FIGURE 7

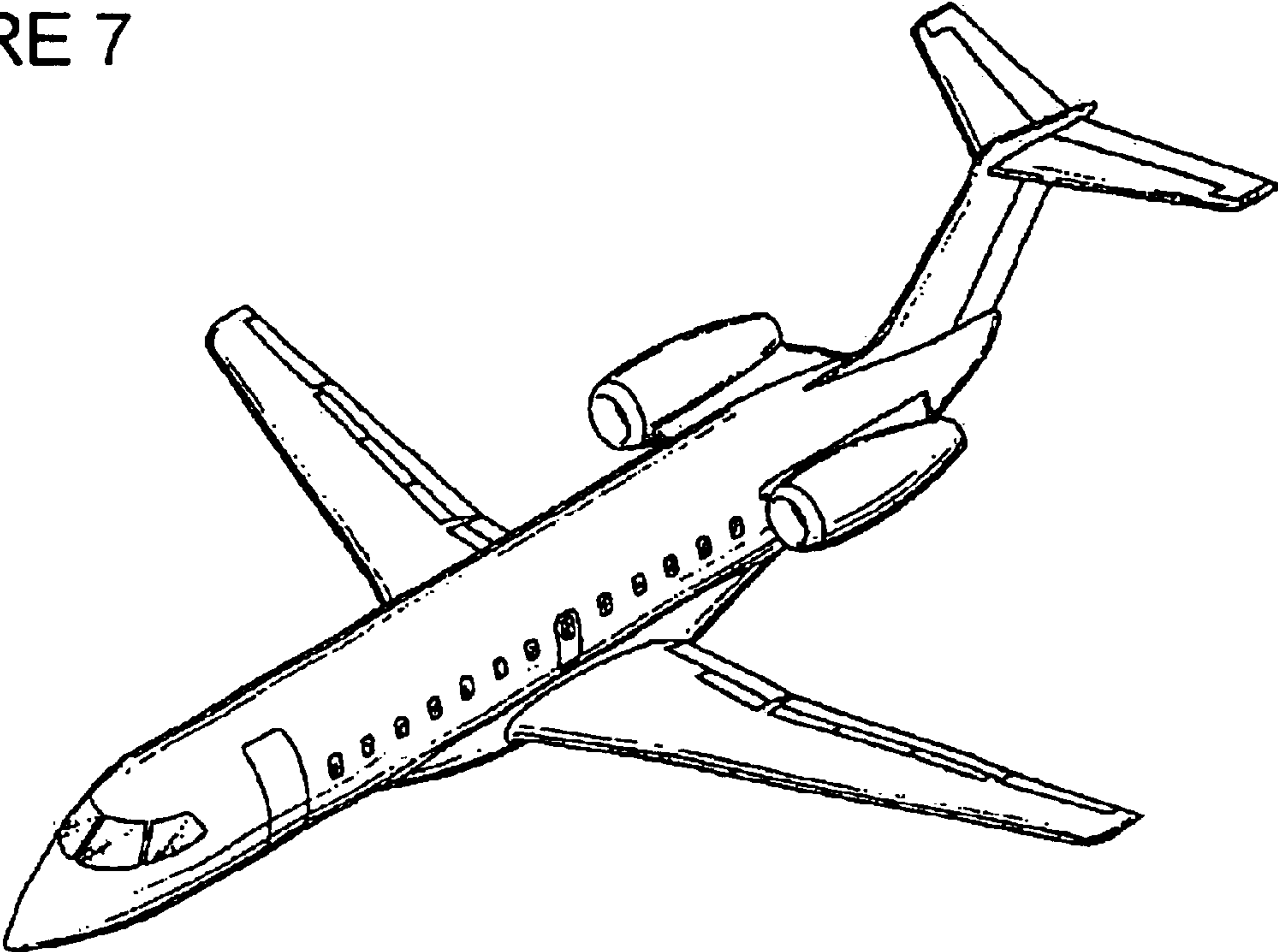

FIGURE 8

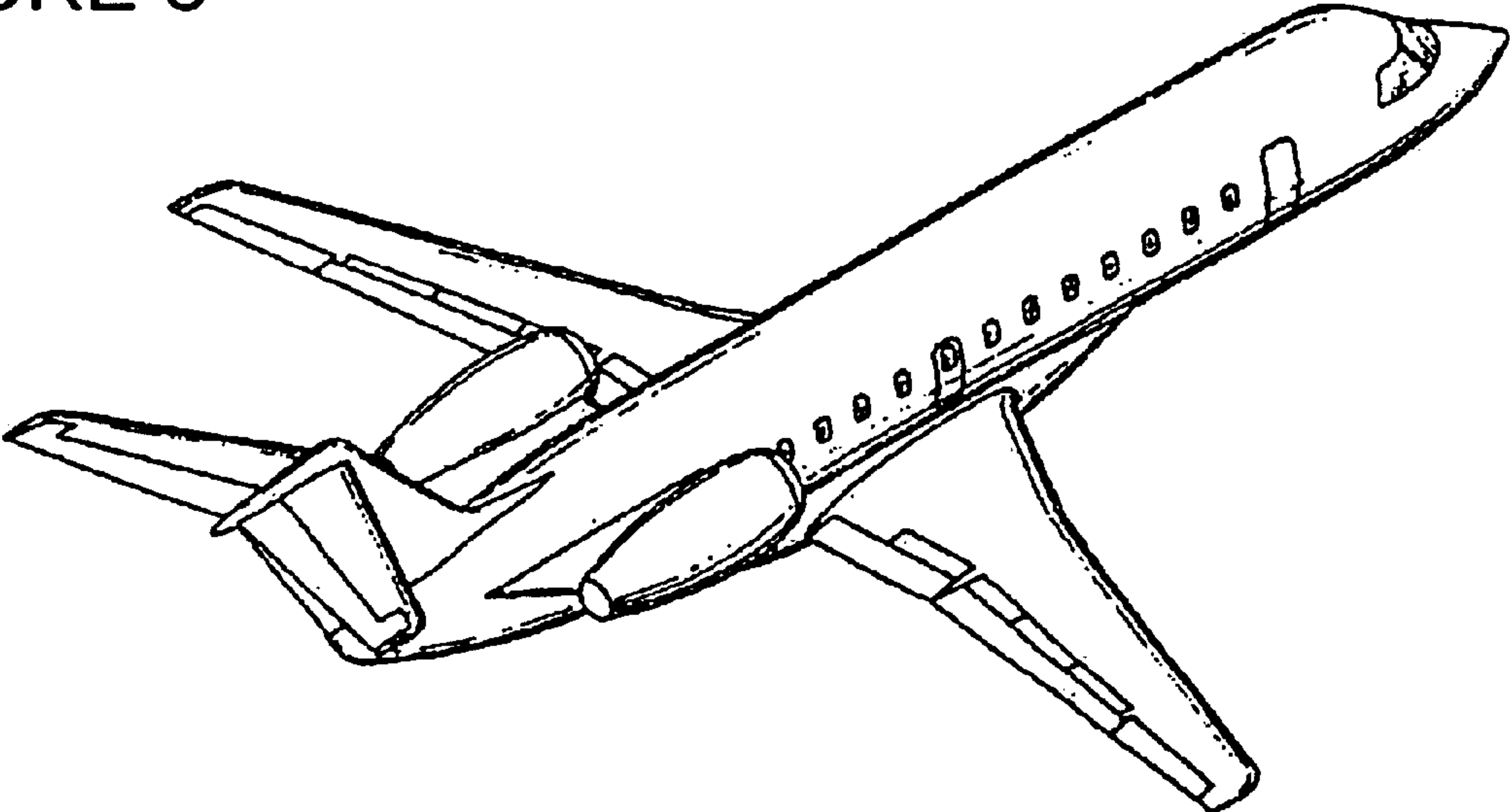

FIGURE 9

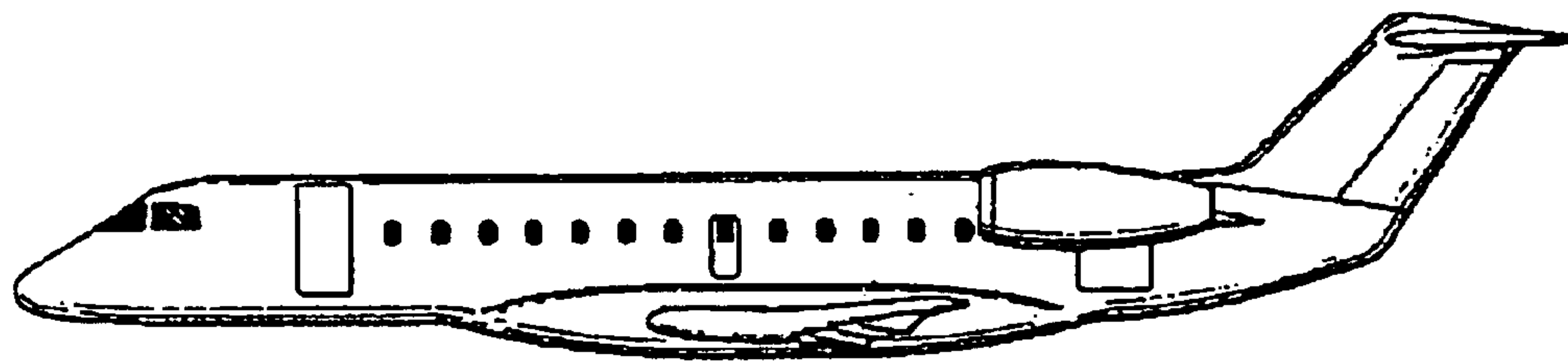

FIGURE 10

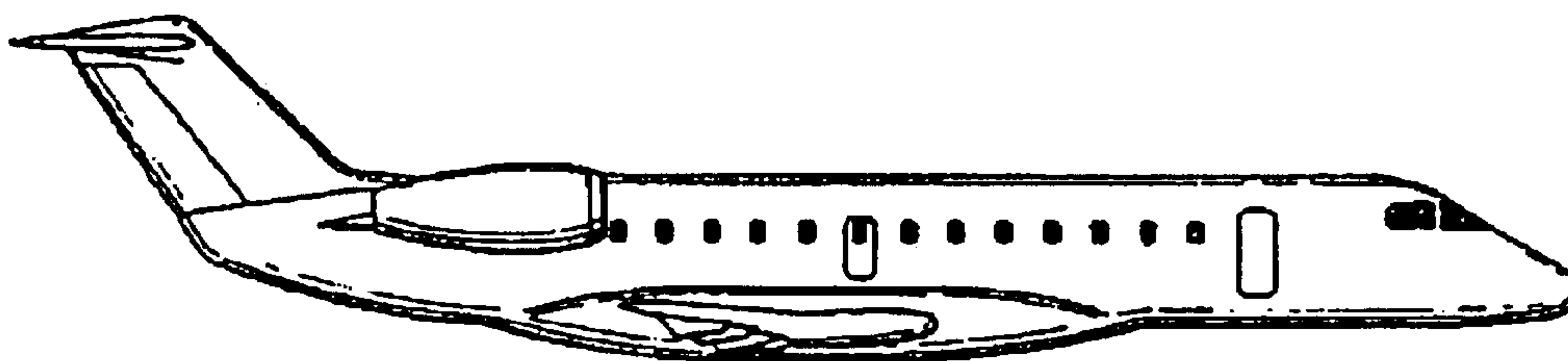

FIGURE 11

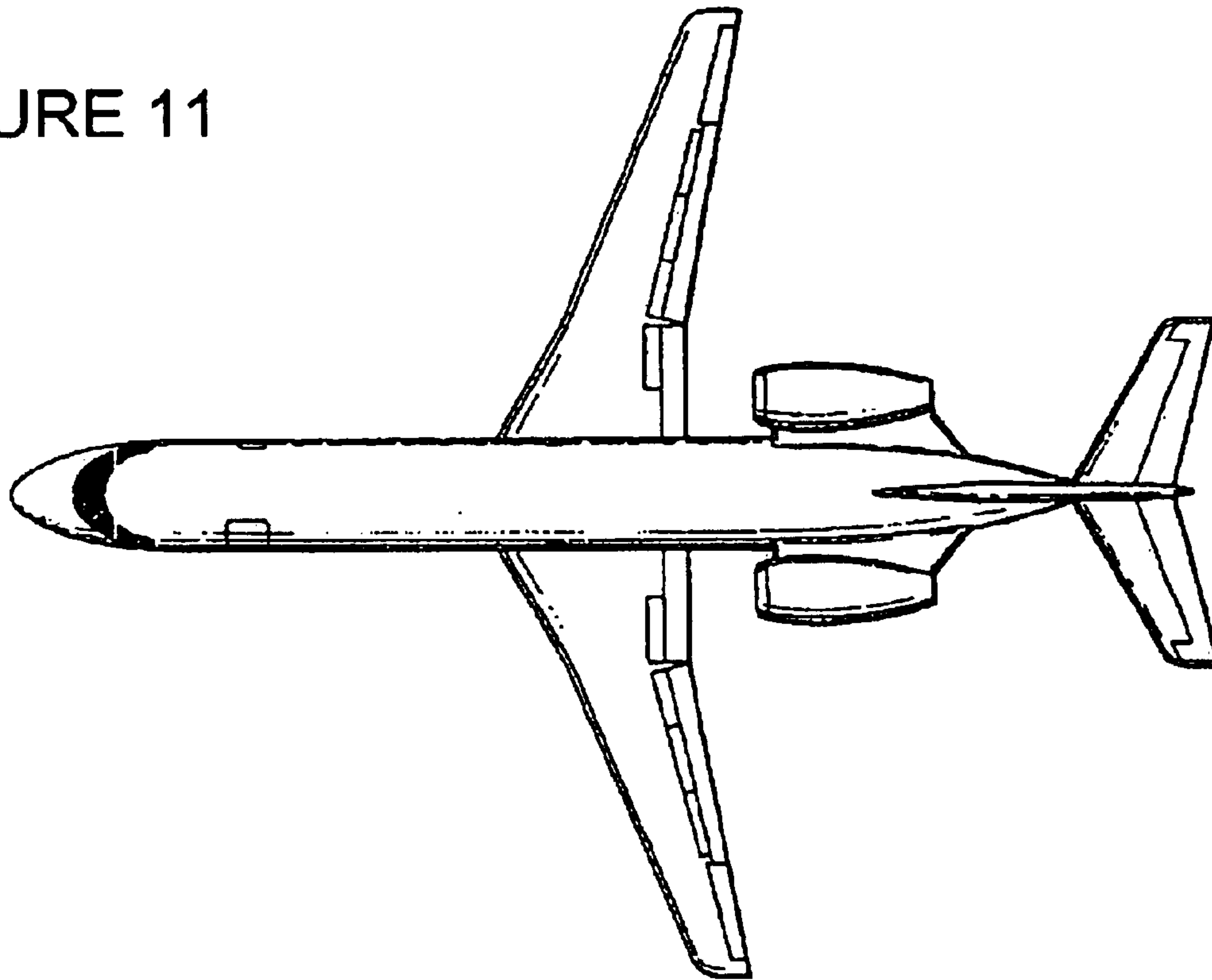

FIGURE 12

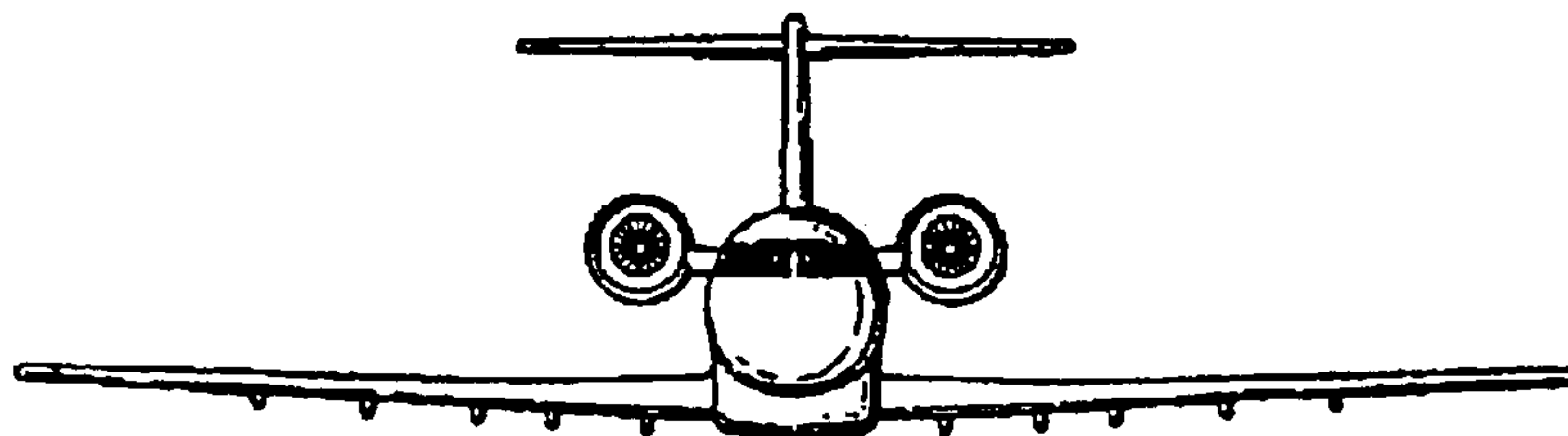

FIGURE 13

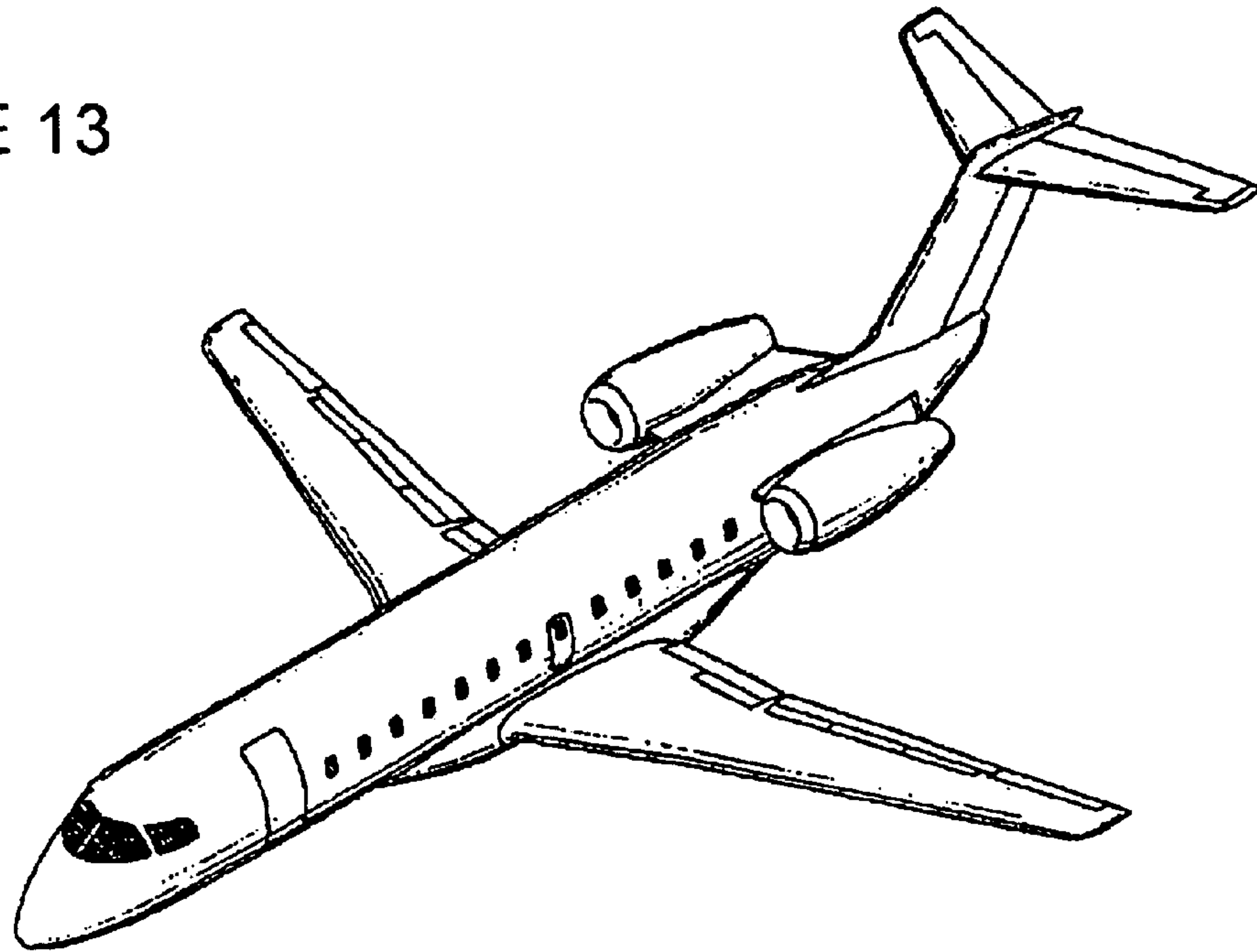

FIGURE 14

