

US00D500056S

(12) **United States Design Patent**  
**DeYoung et al.**

(10) **Patent No.: US D500,056 S**  
(45) **Date of Patent: \*\* Dec. 21, 2004**

(54) **REAR BODY PORTION OF A WORK VEHICLE**

(75) Inventors: **James Thomas DeYoung**, Dubuque, IA (US); **Gregory Keith Werner**, Durango, IA (US); **Kathryn Elizabeth Ehrke**, Davenport, IA (US); **Douglas Gerard Meyer**, Dubuque, IA (US); **Thomas Howard Ward**, Ventura, CA (US); **Stephen Henry Kaminski**, Newbury Park, CA (US)

(73) Assignee: **Deere & Company**, Moline, IL (US)

(\*\*) Term: **14 Years**

(21) Appl. No.: **29/197,002**

(22) Filed: **Jan. 8, 2004**

(51) **LOC (7) Cl. .... 15-03**

(52) **U.S. Cl. .... D15/33; D15/31**

(58) **Field of Search .... D15/22-26, 28, D15/31, 33; 37/455, 442, 443; 414/685, 694, 722, 724; 180/89.1, 89.12, 298, 900, 68.5**

(56) **References Cited**

**U.S. PATENT DOCUMENTS**

D192,091 S	*	1/1962	Lathe	.....	D15/31
D226,707 S	*	4/1973	Skyer et al.	.....	D15/25
D235,113 S	*	5/1975	Hendrickson et al.	.....	D15/25
D245,503 S	*	8/1977	Adams et al.	.....	D15/25
D246,370 S	*	11/1977	Lorenz	.....	D15/31
4,074,786 A	*	2/1978	Joubert	.....	180/68.5
D264,472 S	*	5/1982	Carlson et al.	.....	D15/23

D345,741 S	*	4/1994	Mullett et al.	.....	D15/23
D410,930 S	*	6/1999	Kim et al.	.....	D15/25
D412,506 S	*	8/1999	Boyer et al.	.....	D15/25
D460,085 S	*	7/2002	Crookes et al.	.....	D15/25
D461,831 S	*	8/2002	Laberheim et al.	.....	D15/25

\* cited by examiner

*Primary Examiner*—Mitchell Siegel

(57) **CLAIM**

The ornamental design for a rear body portion of a work vehicle, as shown and described.

**DESCRIPTION**

FIG. 1 is a side view of an embodiment of a rear body portion of a work vehicle. Also illustrated are an exemplary front body portion, exemplary front and rear wheels, an exemplary exhaust pipe, an exemplary pre-cleaner, exemplary access doors and handles, an exemplary operator's cab and exemplary vertical pivots for which the design details are hereby disclaimed and form no part of the claimed design;

FIG. 2 is an oblique and elevated view of a left side and a top of the rear body portion;

FIG. 3 is a front and elevated view of a top and a front side of the rear body portion;

FIG. 4 is an oblique and elevated view of a right side and a top of the rear body portion;

FIG. 5 is a side view of a left side of the rear body portion;

FIG. 6 is a side view of a right side of the rear body portion;

FIG. 7 is a rearward and elevated view of a rear and top of the rear body portion; and,

FIG. 8 is a top and planar view of the rear body portion.

**1 Claim, 8 Drawing Sheets**

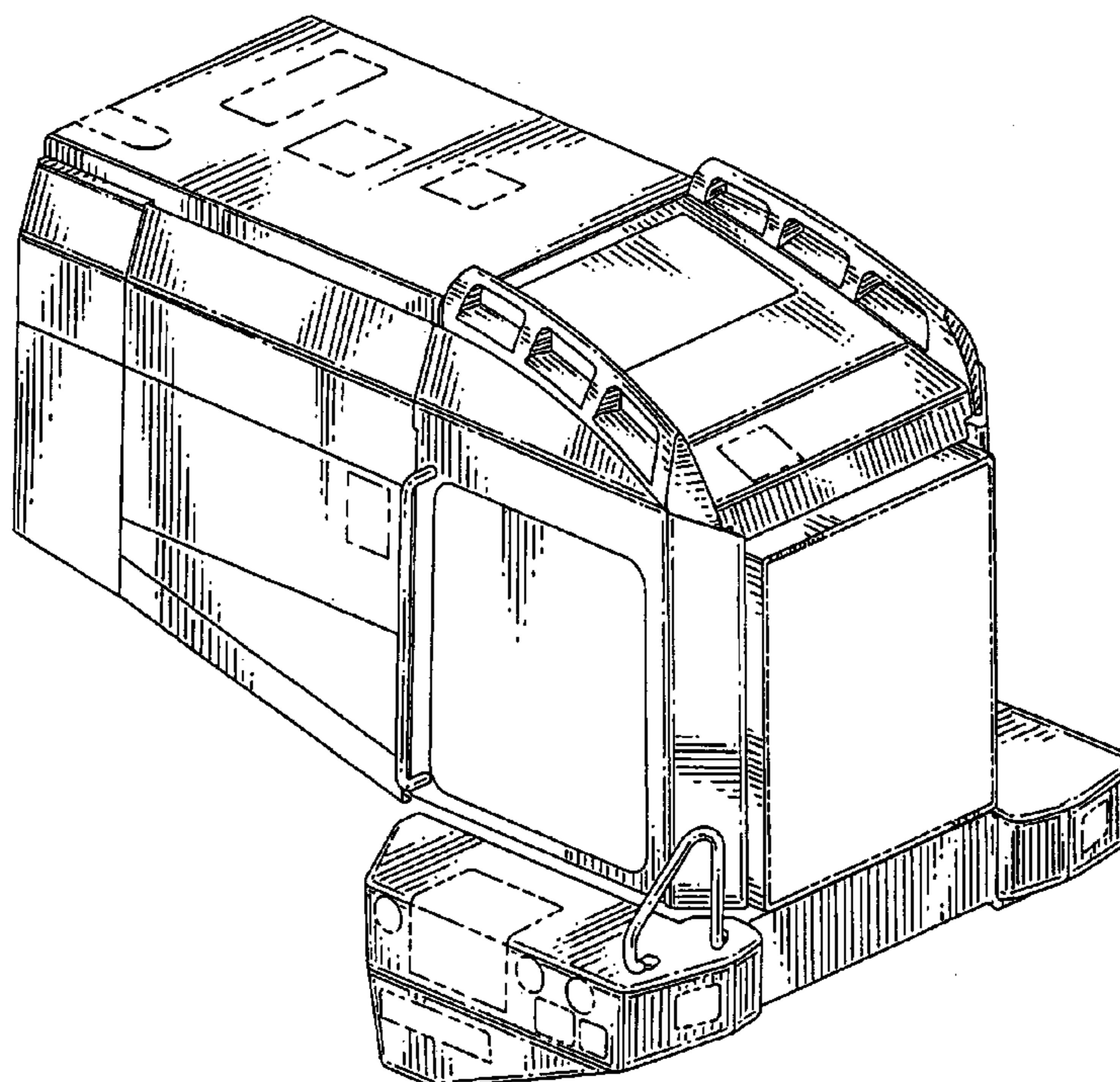

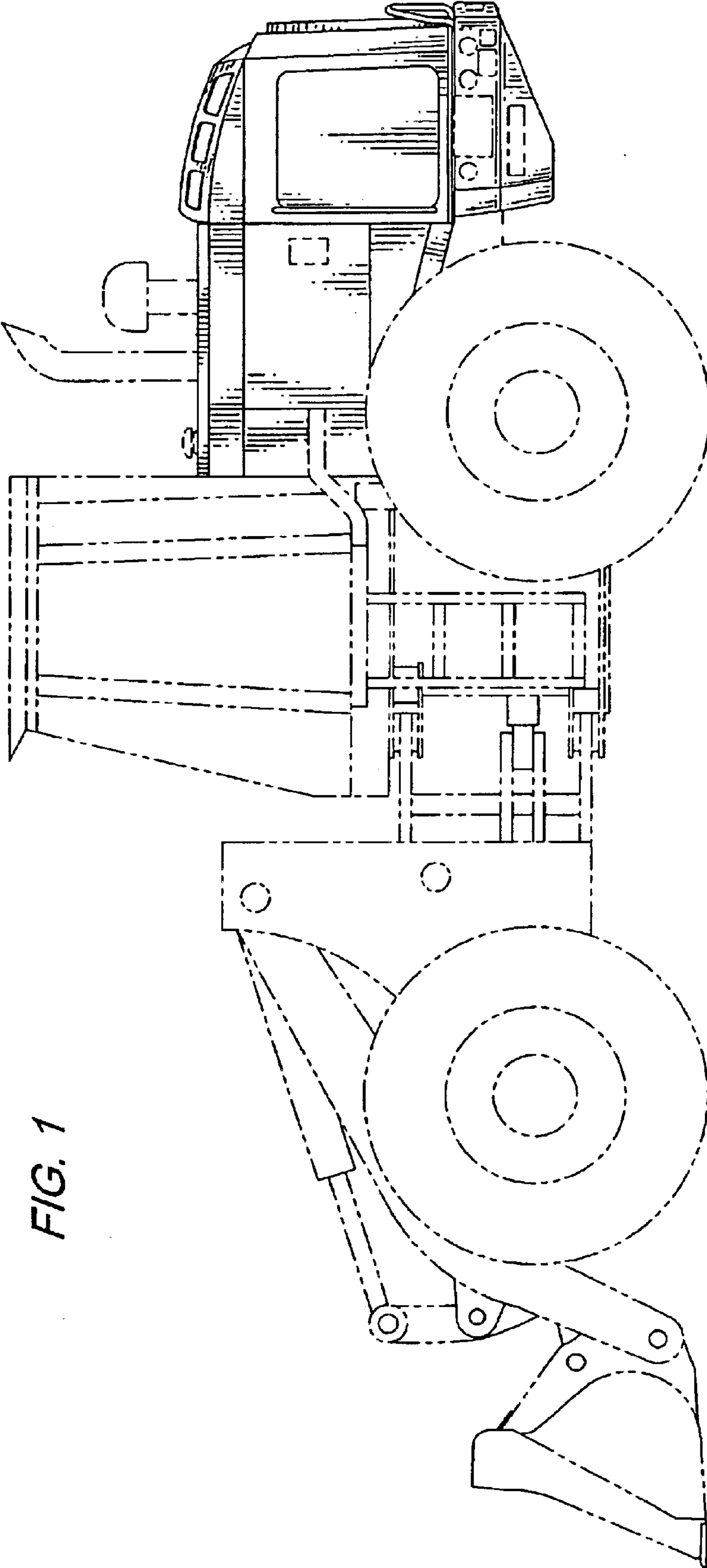

FIG. 1

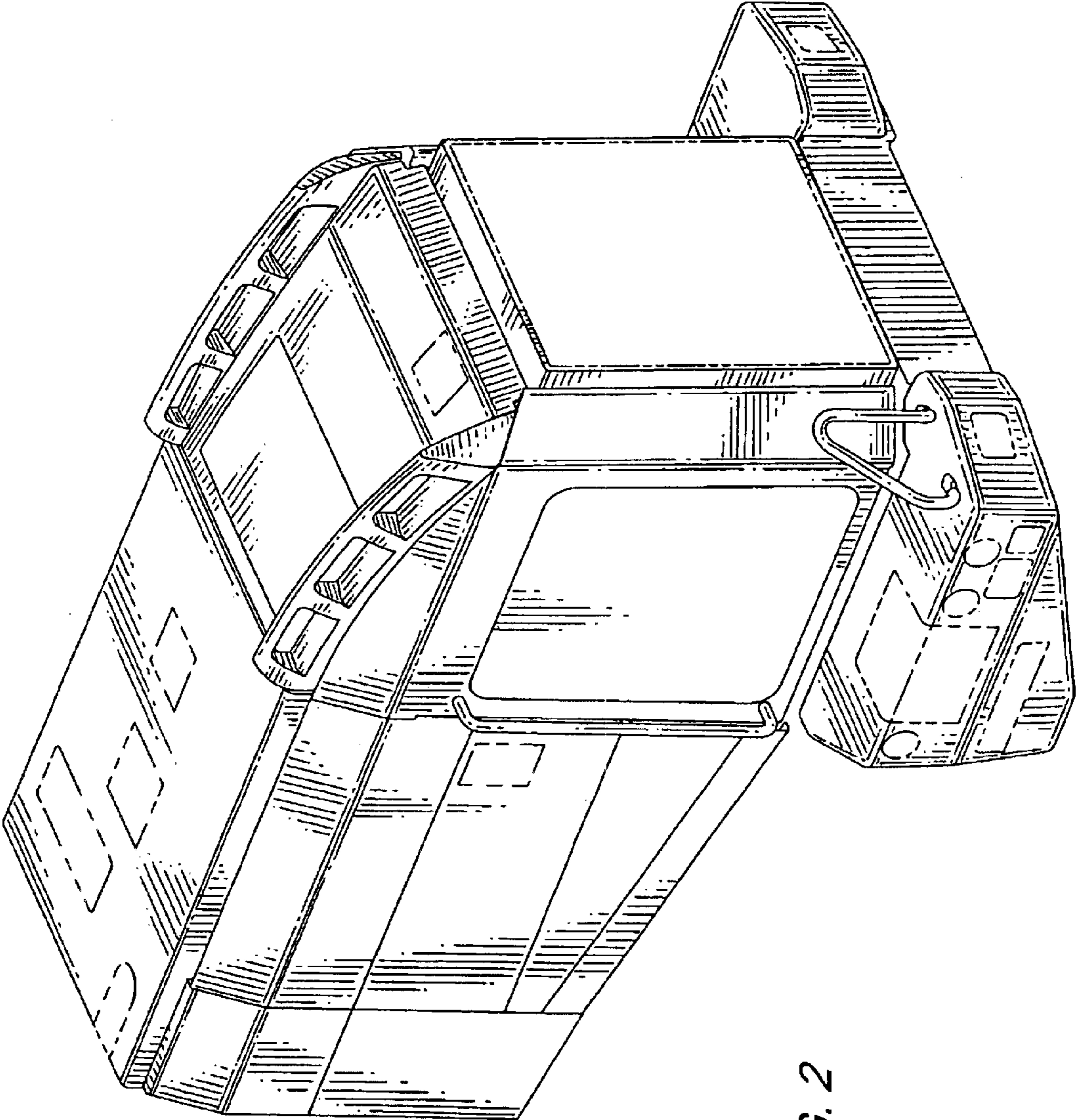
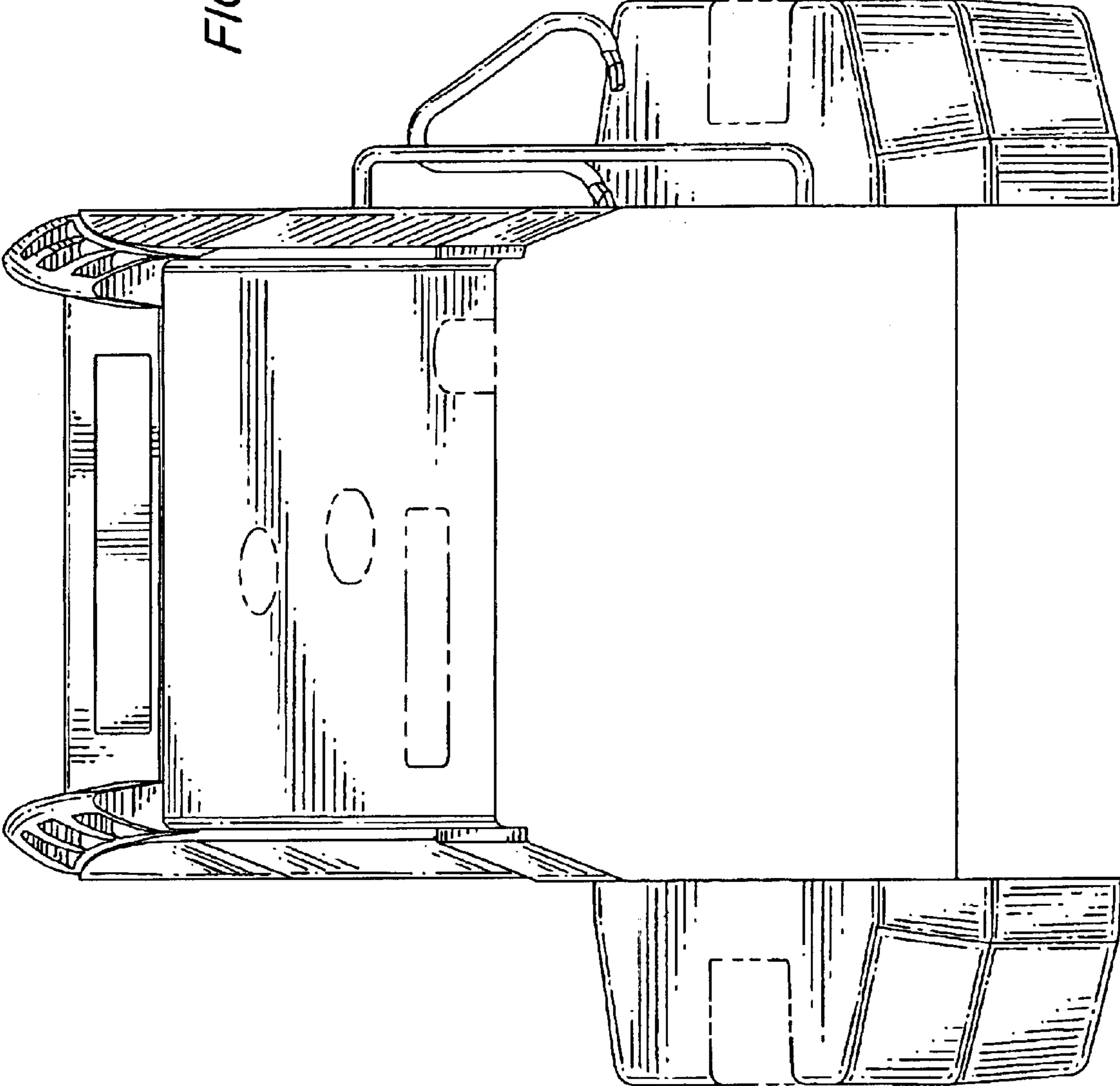

FIG. 2

FIG. 3



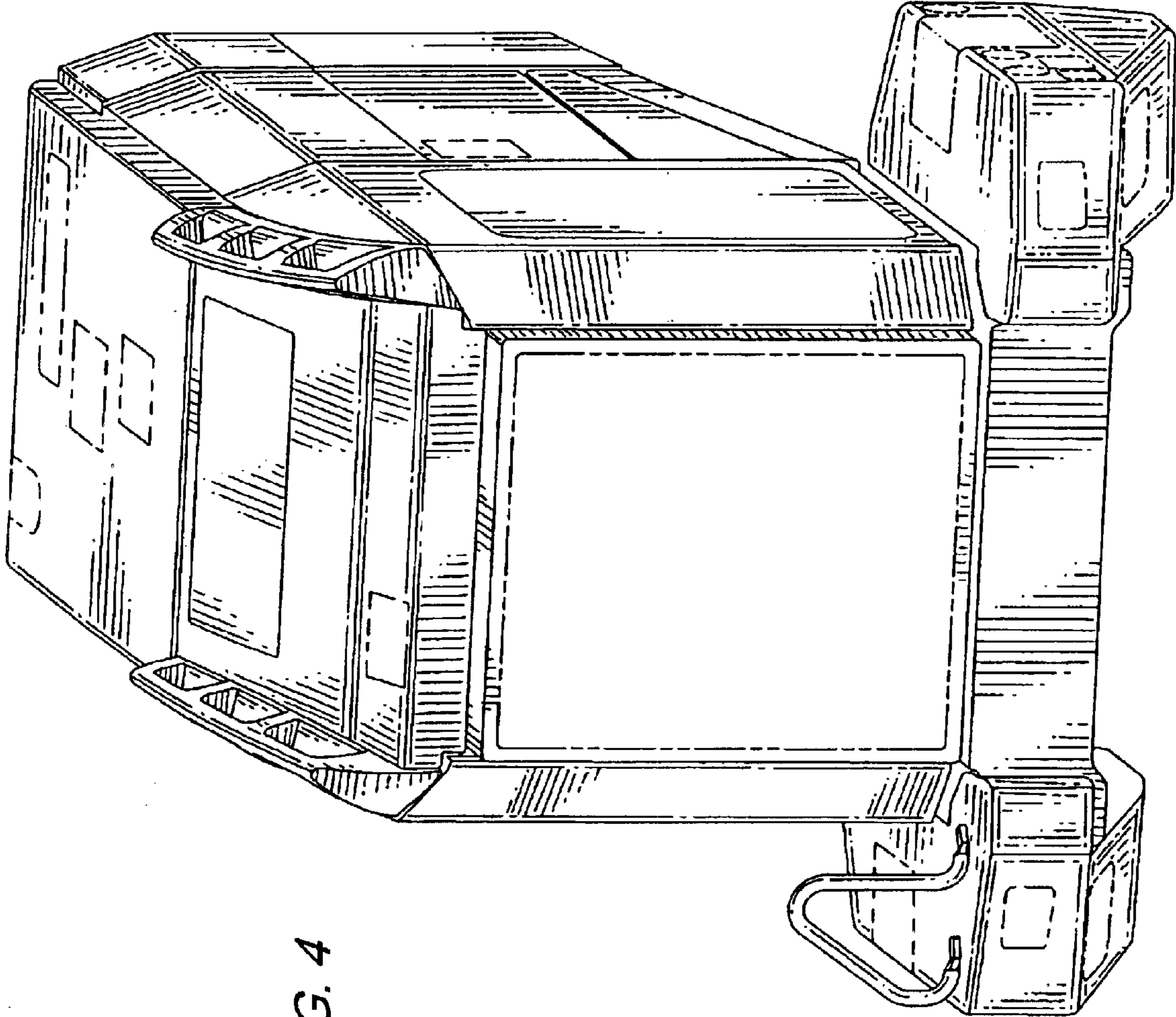

FIG. 4

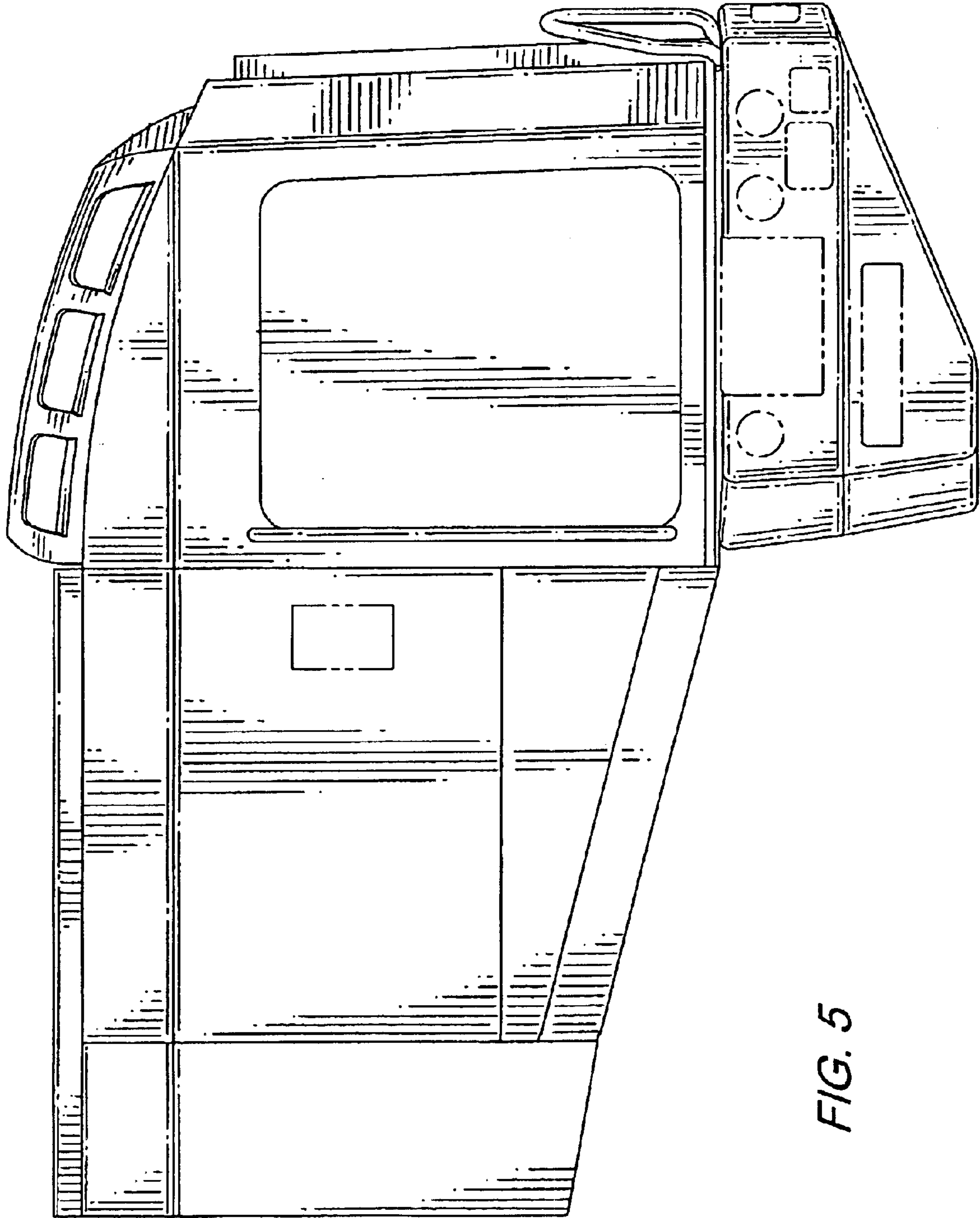

FIG. 5

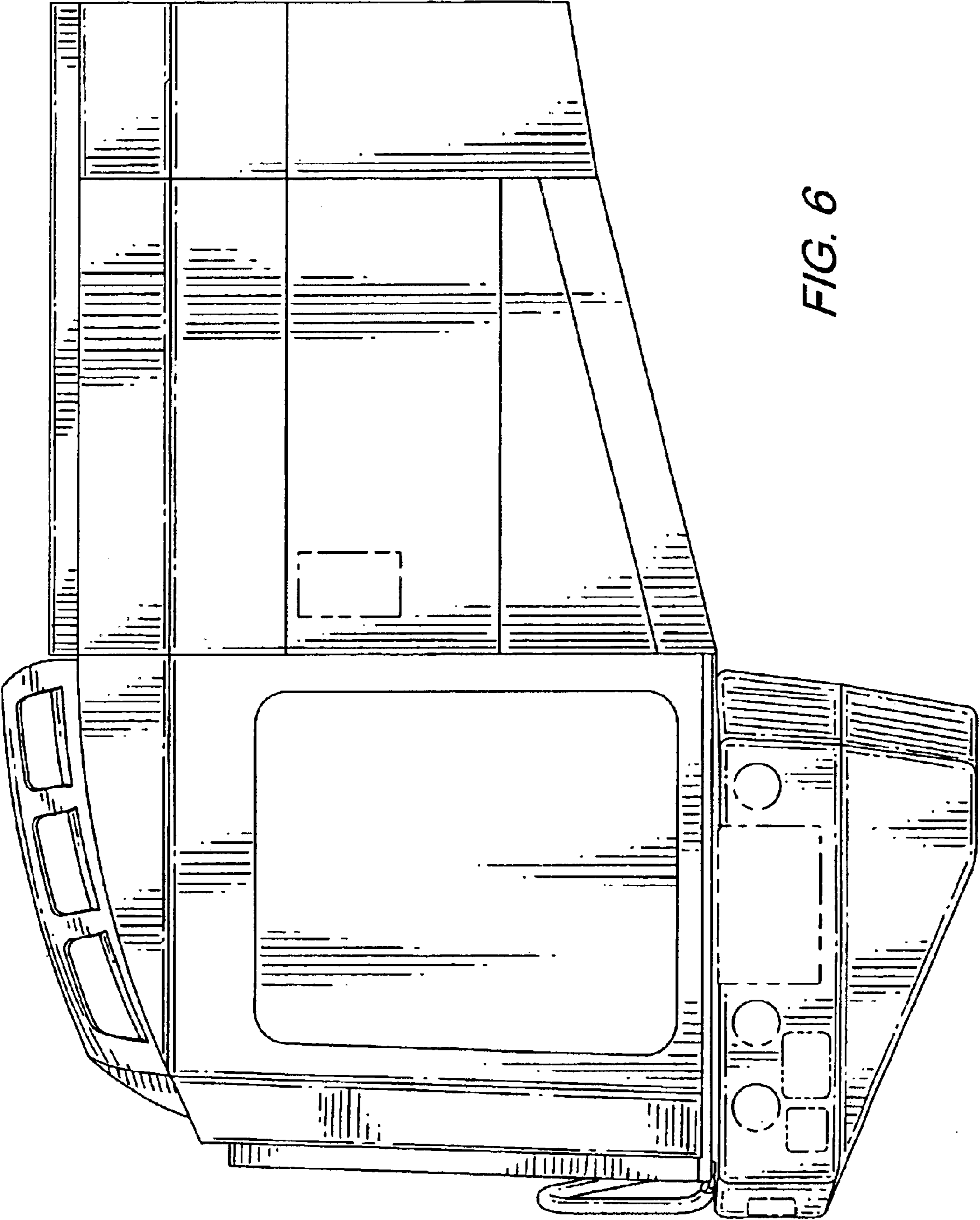
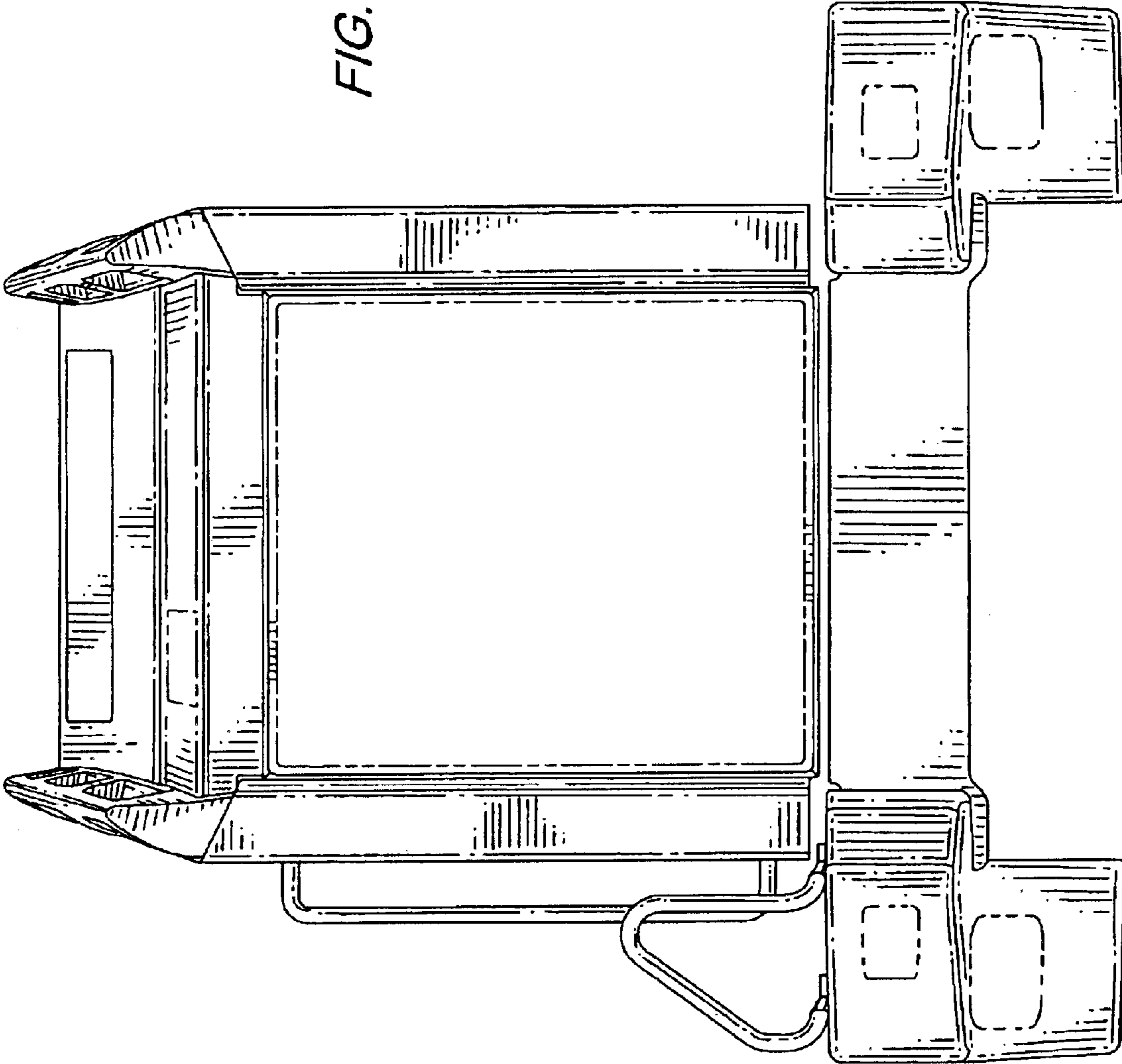

FIG. 6

FIG. 7





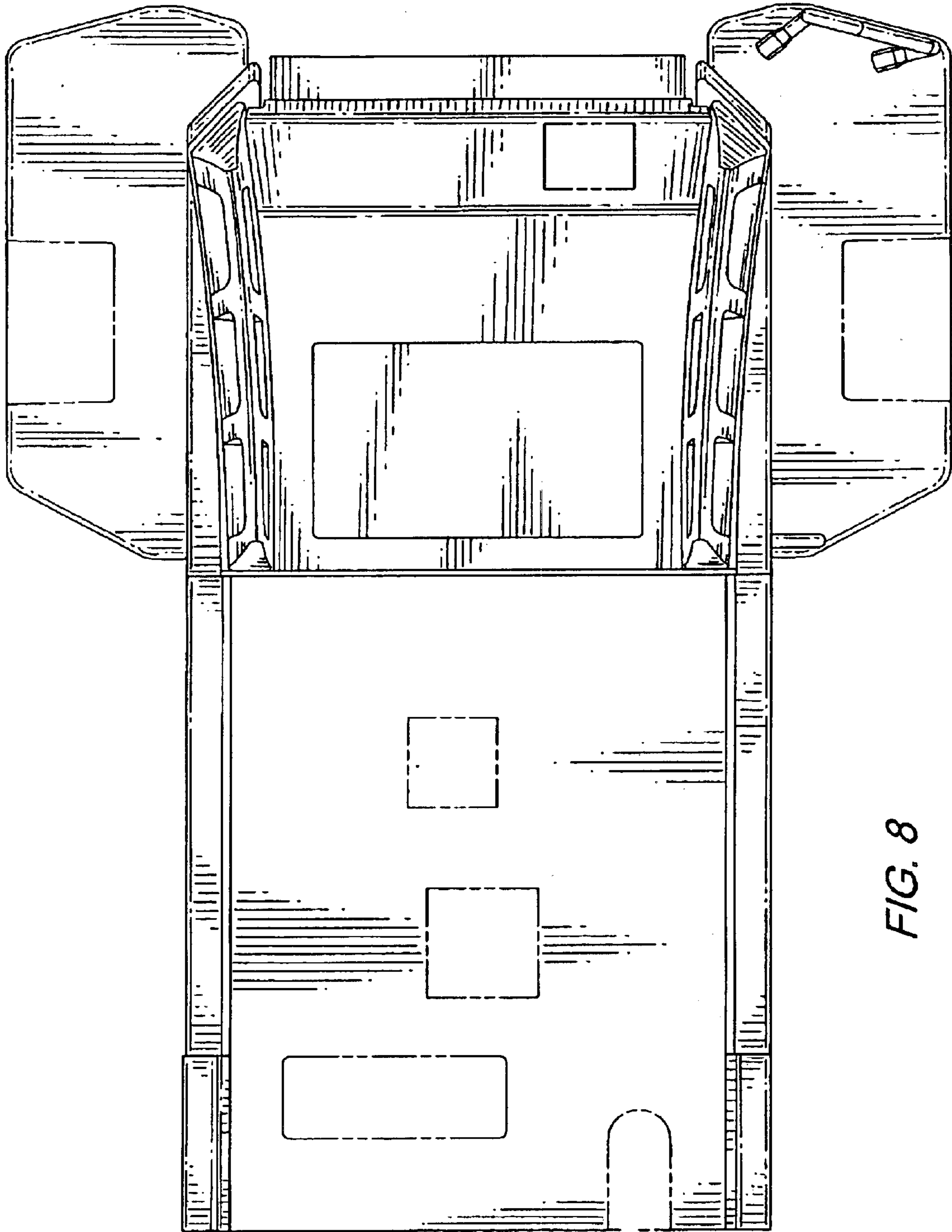

FIG. 8