

US00D500000S

(12) **United States Design Patent**  
**Dyson et al.**

(10) **Patent No.:** **US D500,000 S**  
(45) **Date of Patent:** **\*\* Dec. 21, 2004**

(54) **AUTOMOBILE BODY**

(75) Inventors: **Andrew P Dyson**, West Bloomfield, MI (US); **Joseph S Dehner**, Bloomfield, MI (US); **David C McKinnon**, Bloomfield, MI (US); **Glenn W Abbott**, West Bloomfield, MI (US)

(73) Assignee: **DaimlerChrysler Corporation**, Auburn Hills, MI (US)

(\*\*) Term: **14 Years**

(21) Appl. No.: **29/201,094**

(22) Filed: **Mar. 10, 2004**

(51) **LOC (7) Cl.** ..... **12-08**

(52) **U.S. Cl.** ..... **D12/92**

(58) **Field of Search** ..... D12/90-92, 86;  
D21/424, 433; 296/185

(56) **References Cited**

**U.S. PATENT DOCUMENTS**

D408,328 S	*	4/1999	Ayoub et al.	.....	D12/92
D465,436 S	*	11/2002	Dehner et al.	.....	D12/92
D476,601 S		7/2003	Stoddard et al.	.....	D12/92
D477,253 S	*	7/2003	Minami et al.	.....	D12/92
D483,696 S	*	12/2003	Howell et al.	.....	D12/92

\* cited by examiner

*Primary Examiner*—Melody N. Brown

(74) *Attorney, Agent, or Firm*—Ralph E. Smith

(57) **CLAIM**

The ornamental design for an automobile body, as shown and described.

**DESCRIPTION**

FIG. 1 is a front perspective view of an automobile body showing our new design;

FIG. 2 is a side view thereof;

FIG. 3 is a rear perspective view thereof;

FIG. 4 is a front view thereof;

FIG. 5 is a rear view thereof;

FIG. 6 is a front perspective view of an automobile body showing a second embodiment of our new design;

FIG. 7 is a side view of FIG. 6;

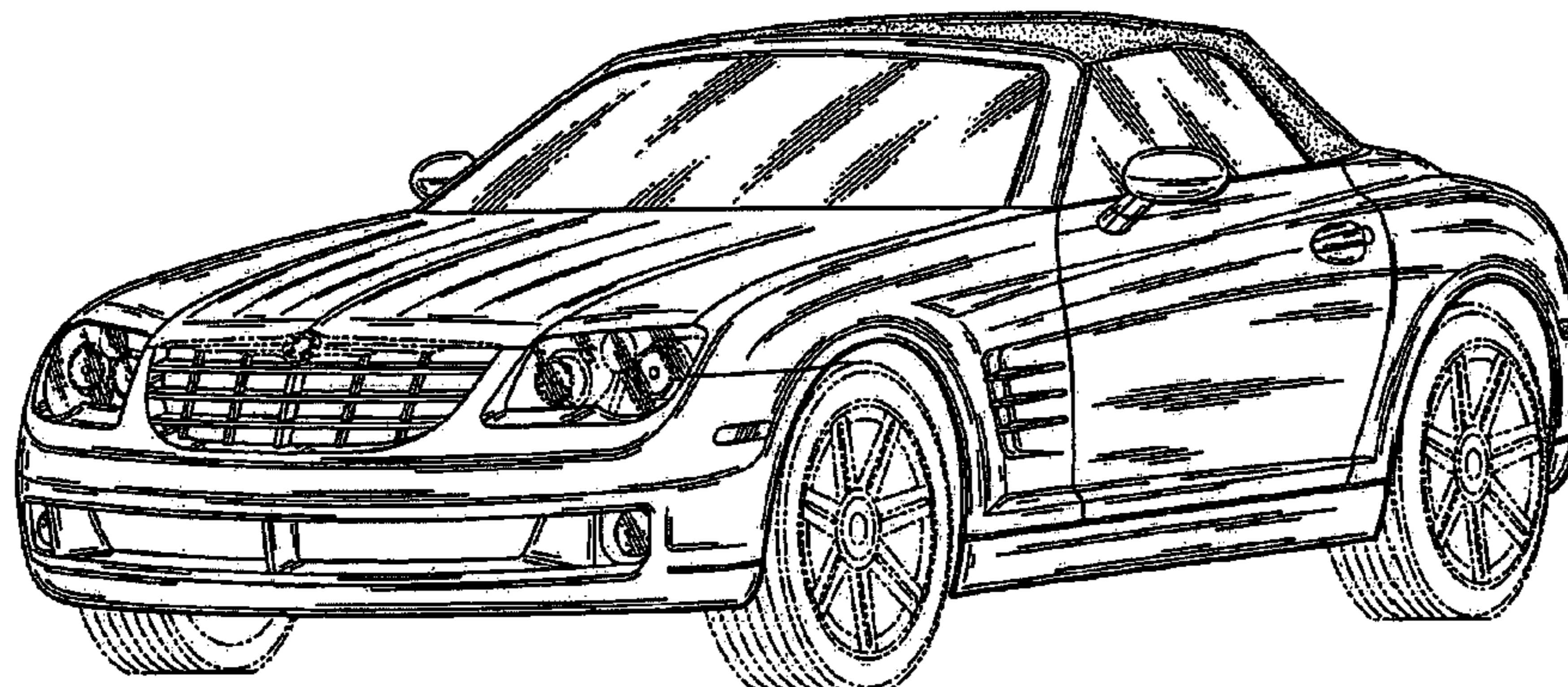
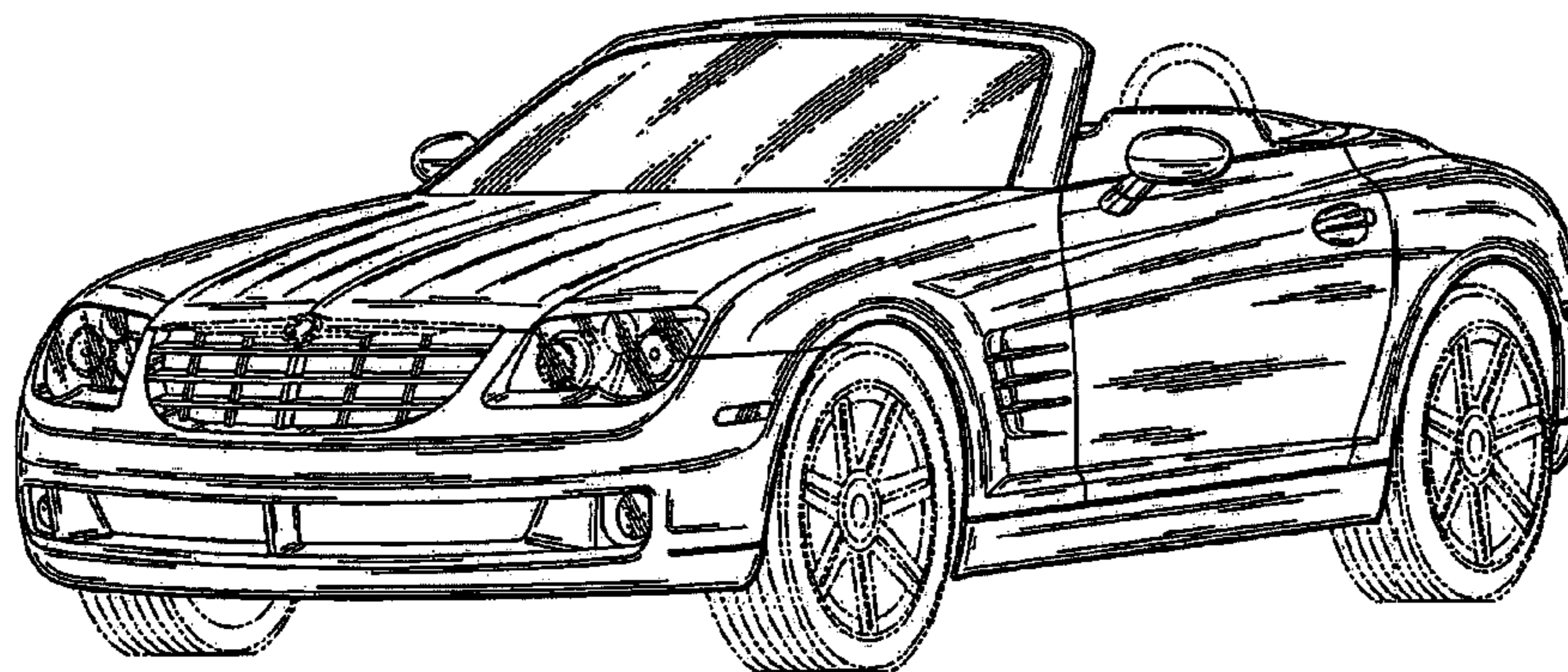
FIG. 8 is a rear perspective view of FIG. 6;

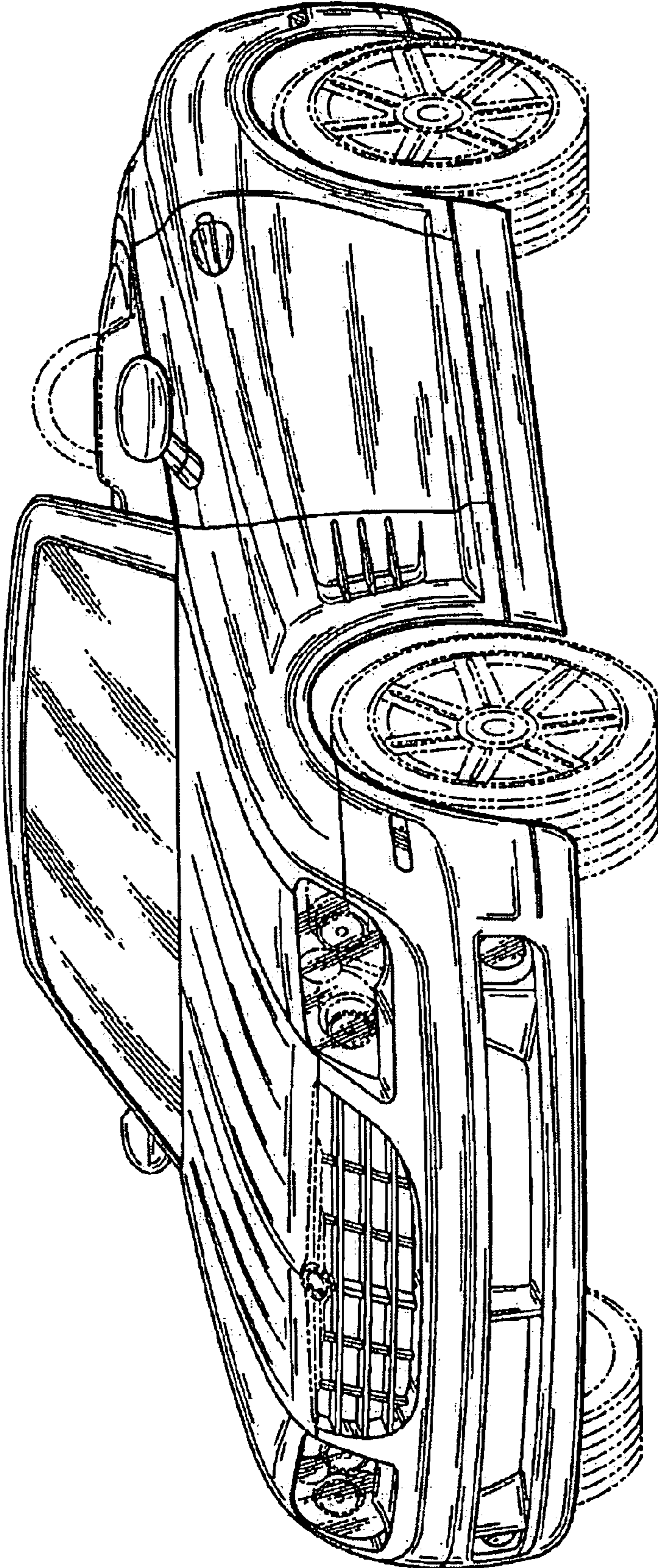
FIG. 9 is a front view of FIG. 6; and,

FIG. 10 is a rear view of FIG. 6.

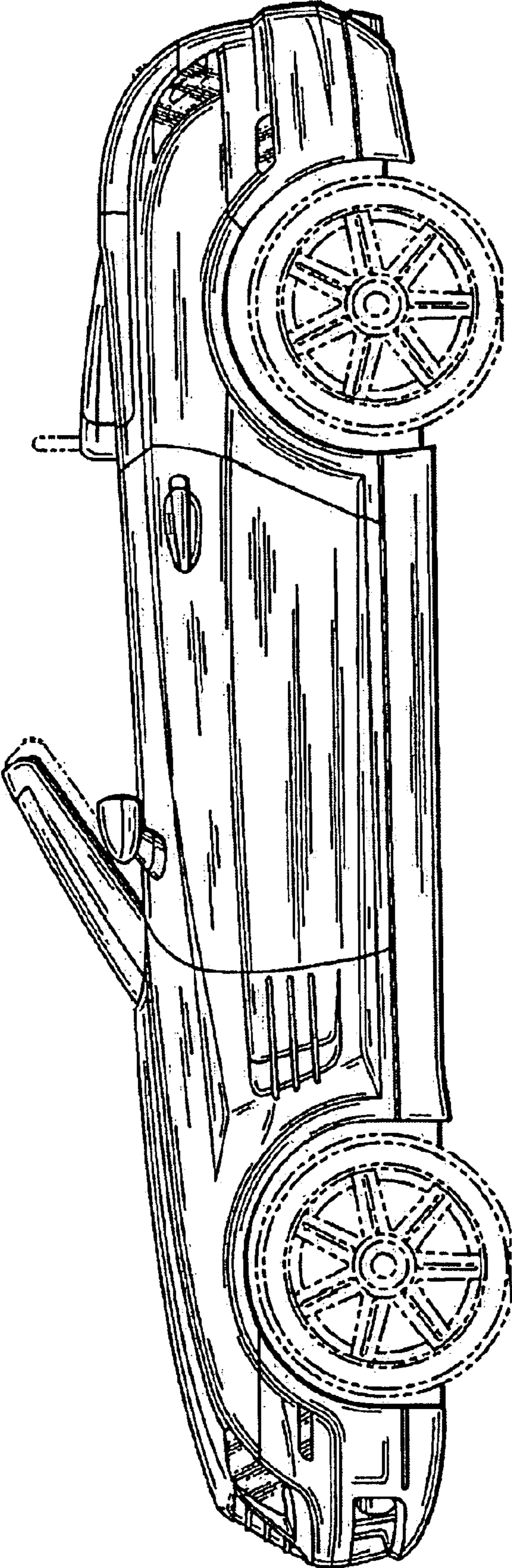
It will be understood that the dashed lines presented in the drawings are for illustration only, and do not form a part of the claimed design.

**1 Claim, 8 Drawing Sheets**

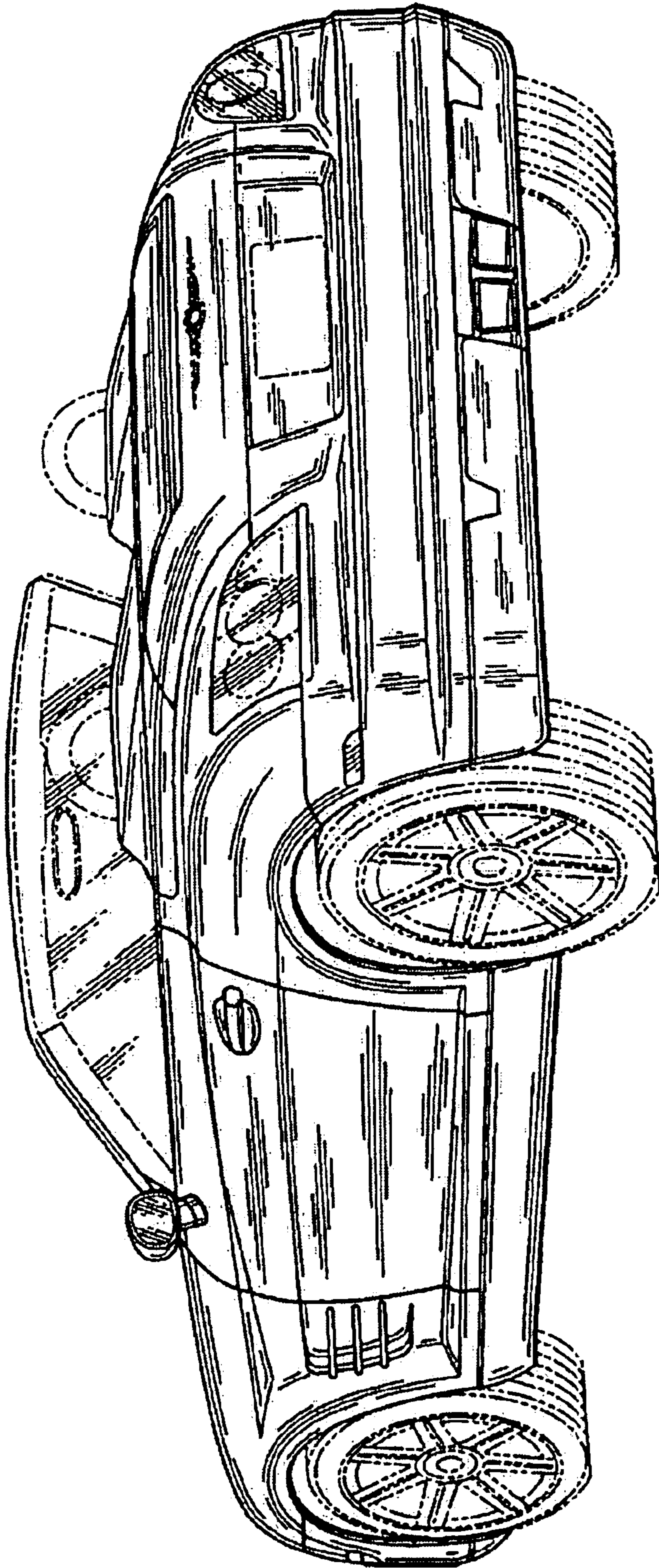




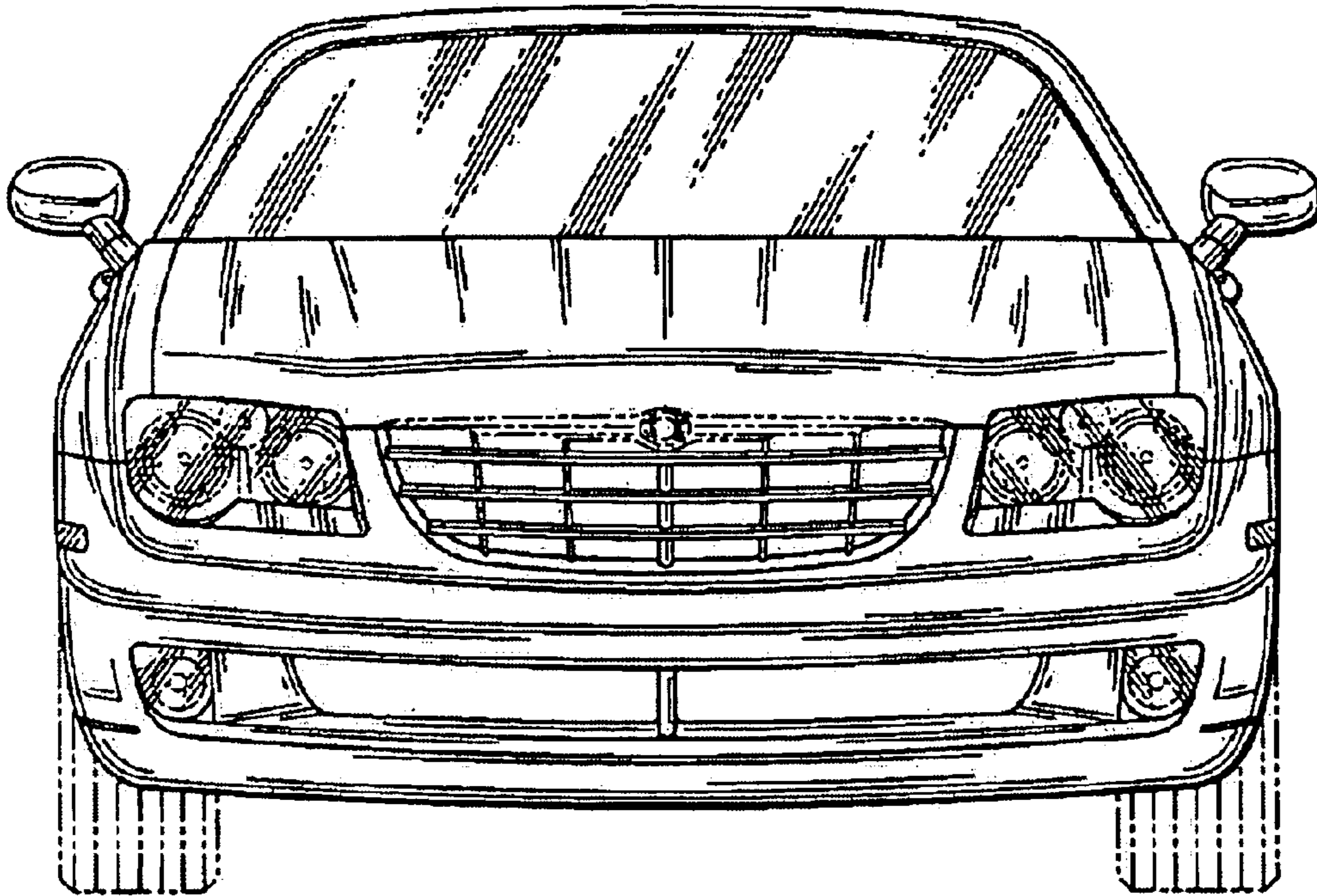
*Fig. 1*



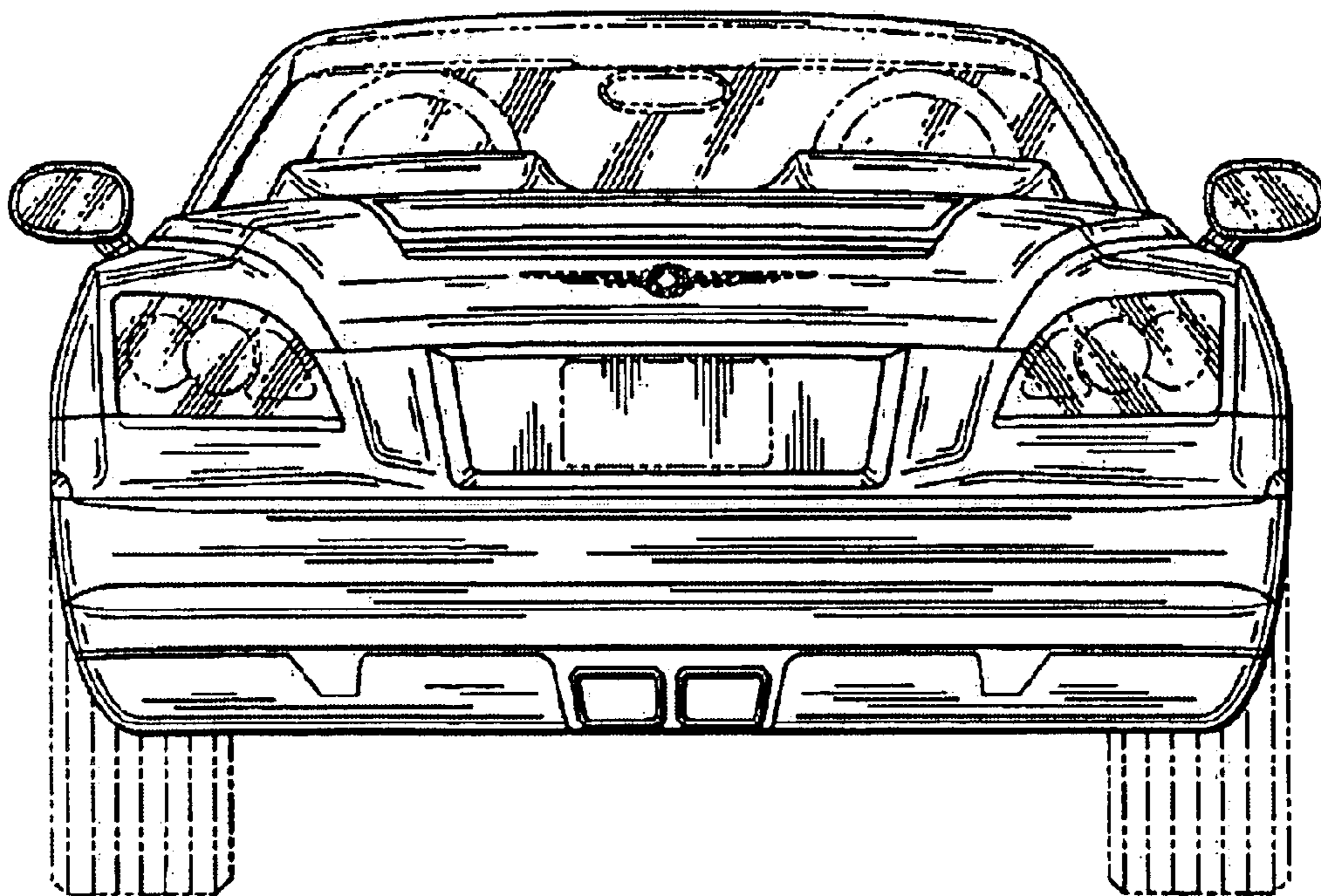
*Fig. 2*



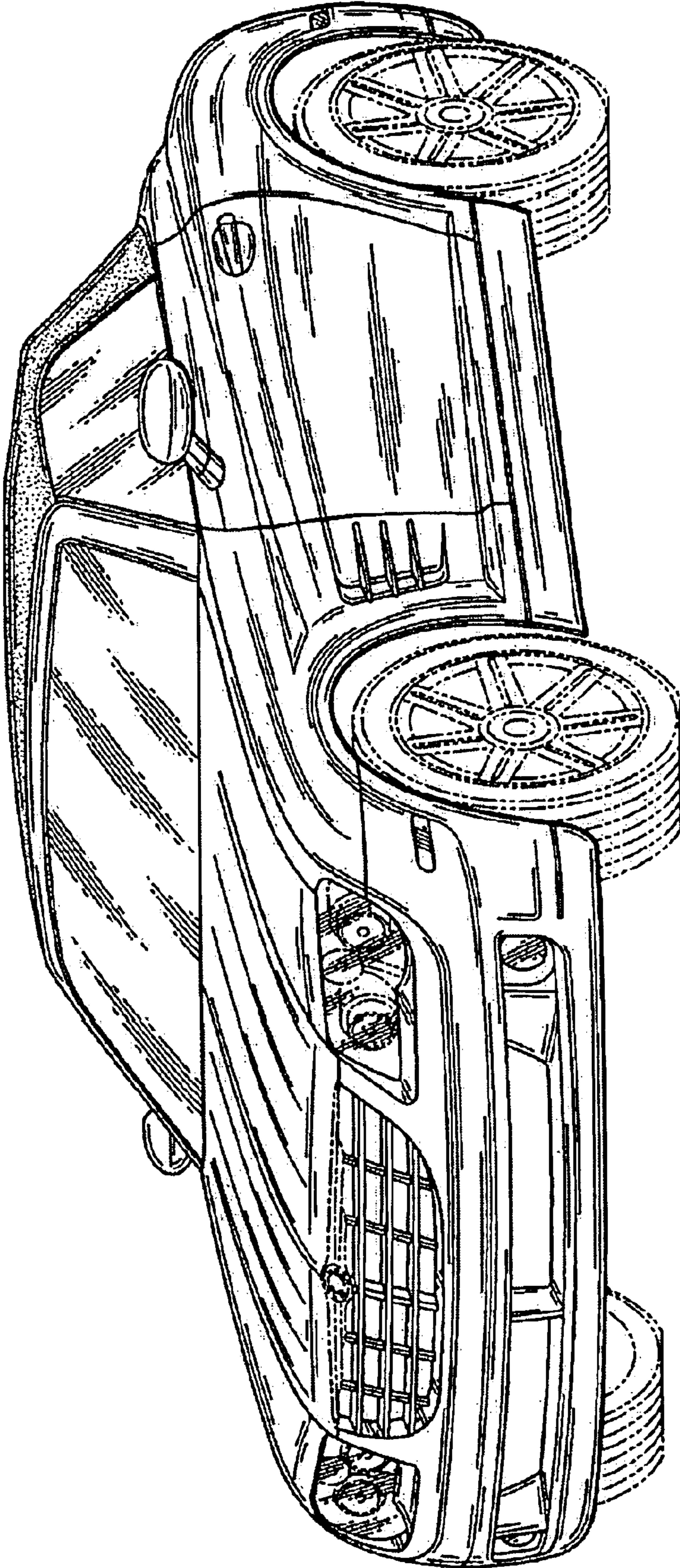
*Fig. 3*



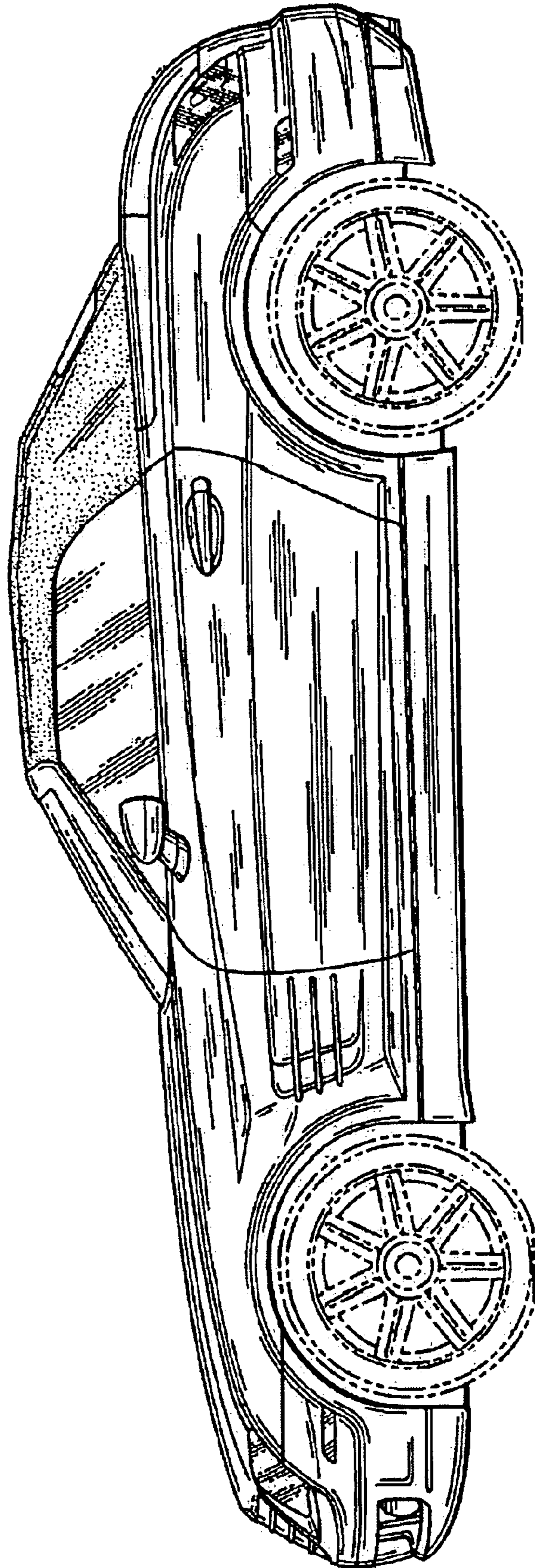
*Fig. 4*



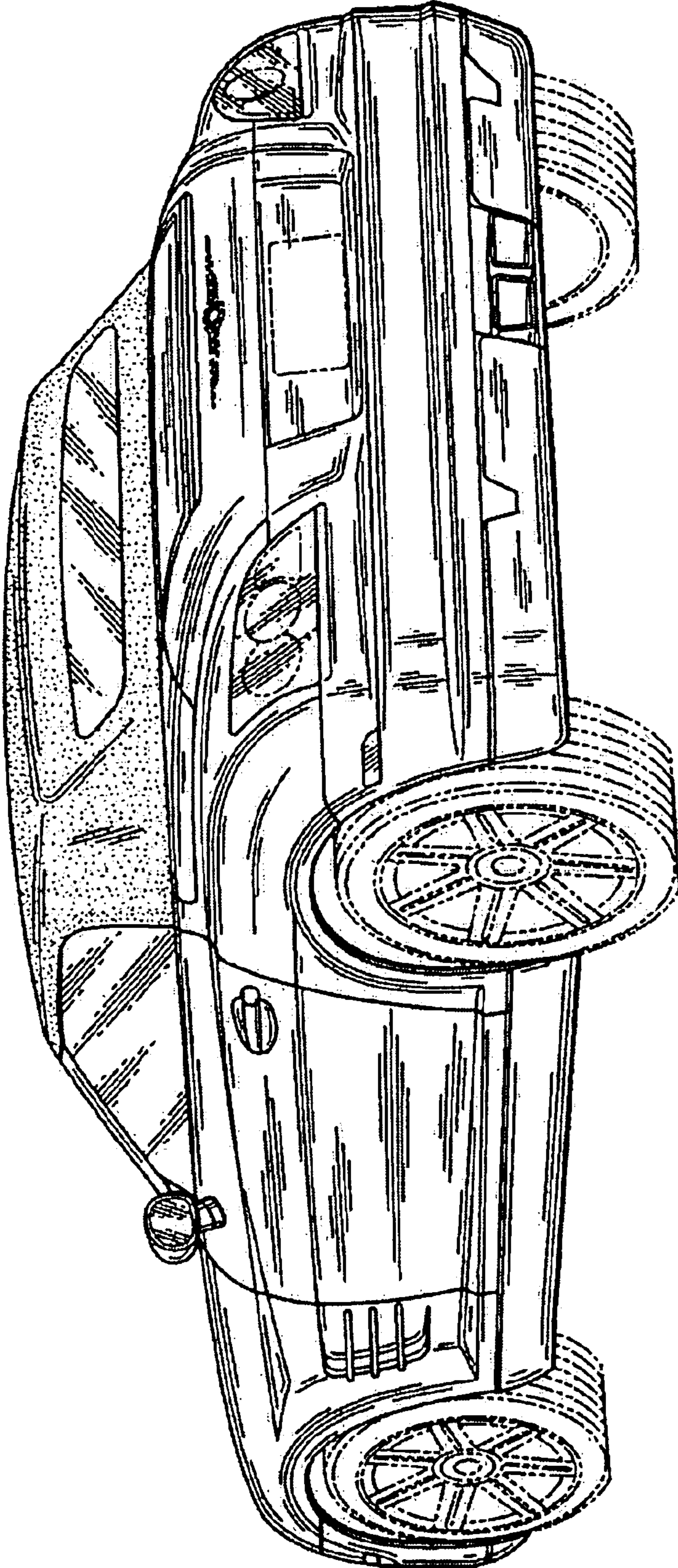
*Fig. 5*



*Fig. 6*

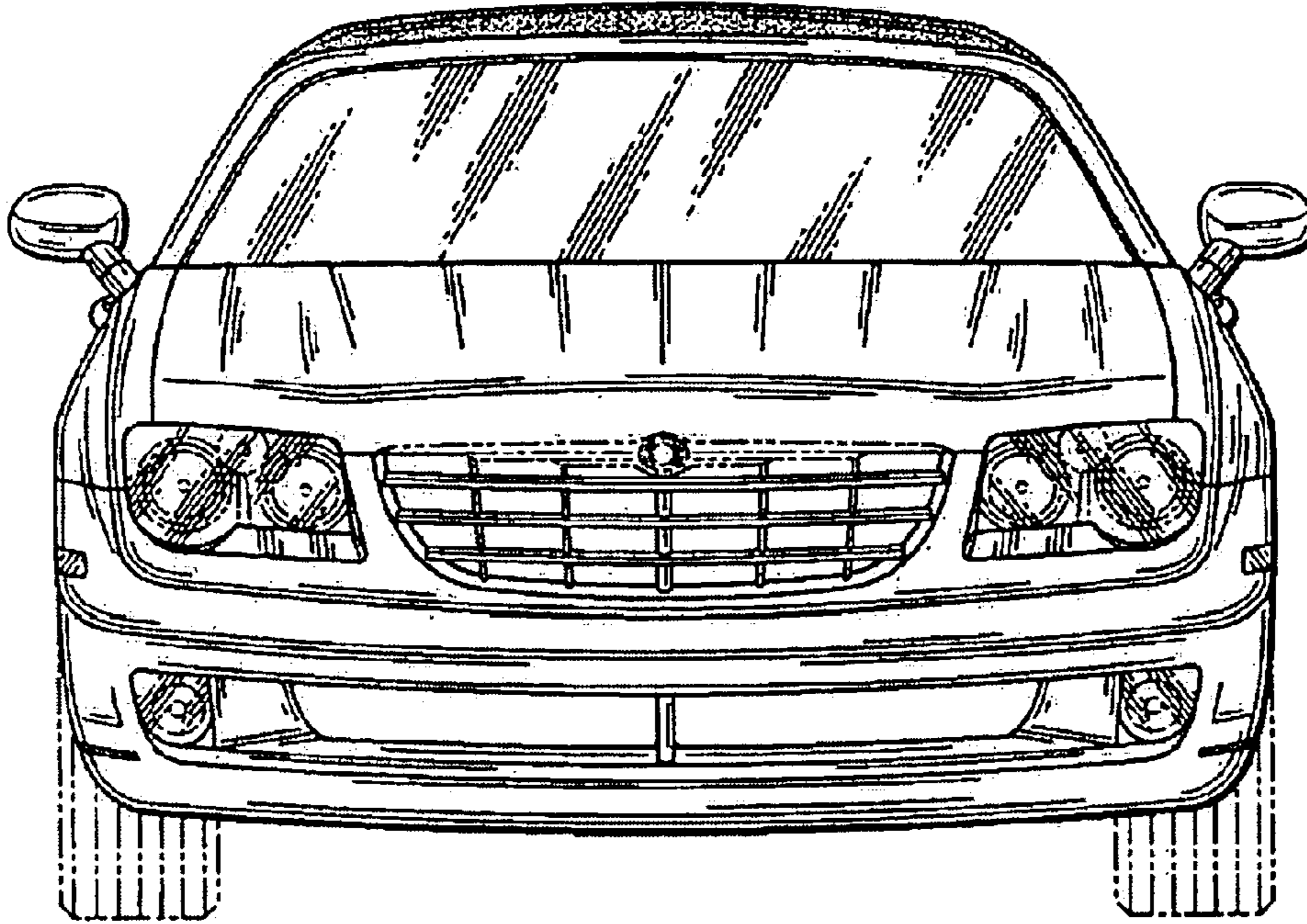


*Fig. 7*

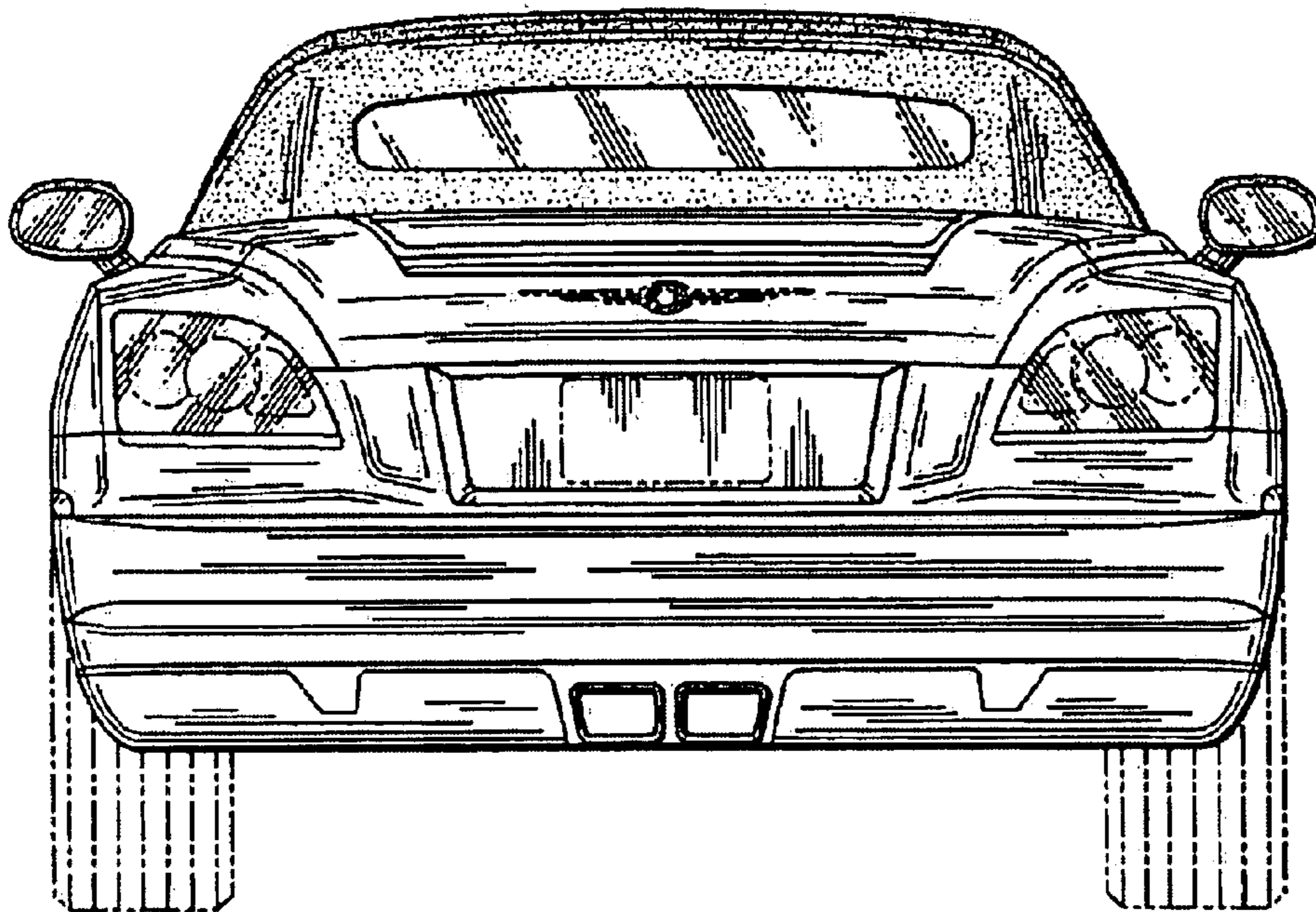


*Fig. 8*





*Fig. 9*



*Fig. 10*