



US00D499996S

(12) **United States Design Patent** (10) **Patent No.:** **US D499,996 S**
Hall et al. (45) **Date of Patent:** **** Dec. 21, 2004**

(54) **VEHICLE SIDE MIRROR**

DESCRIPTION

(75) Inventors: **Jarad W. Hall**, Manhattan Beach, CA (US); **Thomas H. Kim**, Reseda, CA (US)
(73) Assignee: **Honda Motor Co., Ltd.**, Tokyo (JP)
(**) Term: **14 Years**
(21) Appl. No.: **29/195,249**
(22) Filed: **Dec. 10, 2003**
(51) **LOC (7) Cl.** **12-16**
(52) **U.S. Cl.** **D12/187**
(58) **Field of Search** D12/187-189;
359/838-851, 855-868, 871-881

FIG. 1 is a rear perspective view of a vehicle side mirror showing our new design;
FIG. 2 is a front perspective view thereof;
FIG. 3 is a rear elevational view thereof;
FIG. 4 is a front elevational view thereof;
FIG. 5 is a side elevational view thereof;
FIG. 6 is a top elevational view thereof;
FIG. 7 is a bottom elevational view thereof;
FIG. 8 is a rear perspective view of a right-hand version thereof;
FIG. 9 is a front perspective view of a right-hand version thereof;
FIG. 10 is a rear elevational view of a right-hand version thereof;
FIG. 11 is a front elevational view of a right-hand version thereof;
FIG. 12 is a side elevational view of a right-hand version thereof;
FIG. 13 is a top elevational view of a right-hand version thereof; and,
FIG. 14 is a bottom elevational view of a right-hand version thereof.
The vehicle side mirror illustrated in FIGS. 1-7 is left-handed, and FIGS. 8-14 illustrate the right-handed version of the mirror having the same design. The broken line showing of the rectangular area in FIGS. 7 and 14 are for illustrative purposes only and forms no part of the claimed design.

(56) **References Cited**

U.S. PATENT DOCUMENTS

D330,001 S	*	10/1992	Sacco et al.	D12/187
D332,771 S	*	1/1993	Sacco et al.	D12/187
D405,745 S	*	2/1999	Stirling	D12/187
D422,955 S	*	4/2000	Gabath	D12/187
D430,839 S	*	9/2000	Goplen	D12/187
D450,643 S	*	11/2001	Terzano	D12/187
D457,114 S	*	5/2002	Lang et al.	D12/187
D462,305 S	*	9/2002	Abalos et al.	D12/187
6,598,983 B1	*	7/2003	Boddy	359/841

* cited by examiner

Primary Examiner—Melody N. Brown
(74) *Attorney, Agent, or Firm*—Plumsea Law Group, LLC

(57) **CLAIM**

The ornamental design for a vehicle side mirror, as shown and described.

1 Claim, 6 Drawing Sheets

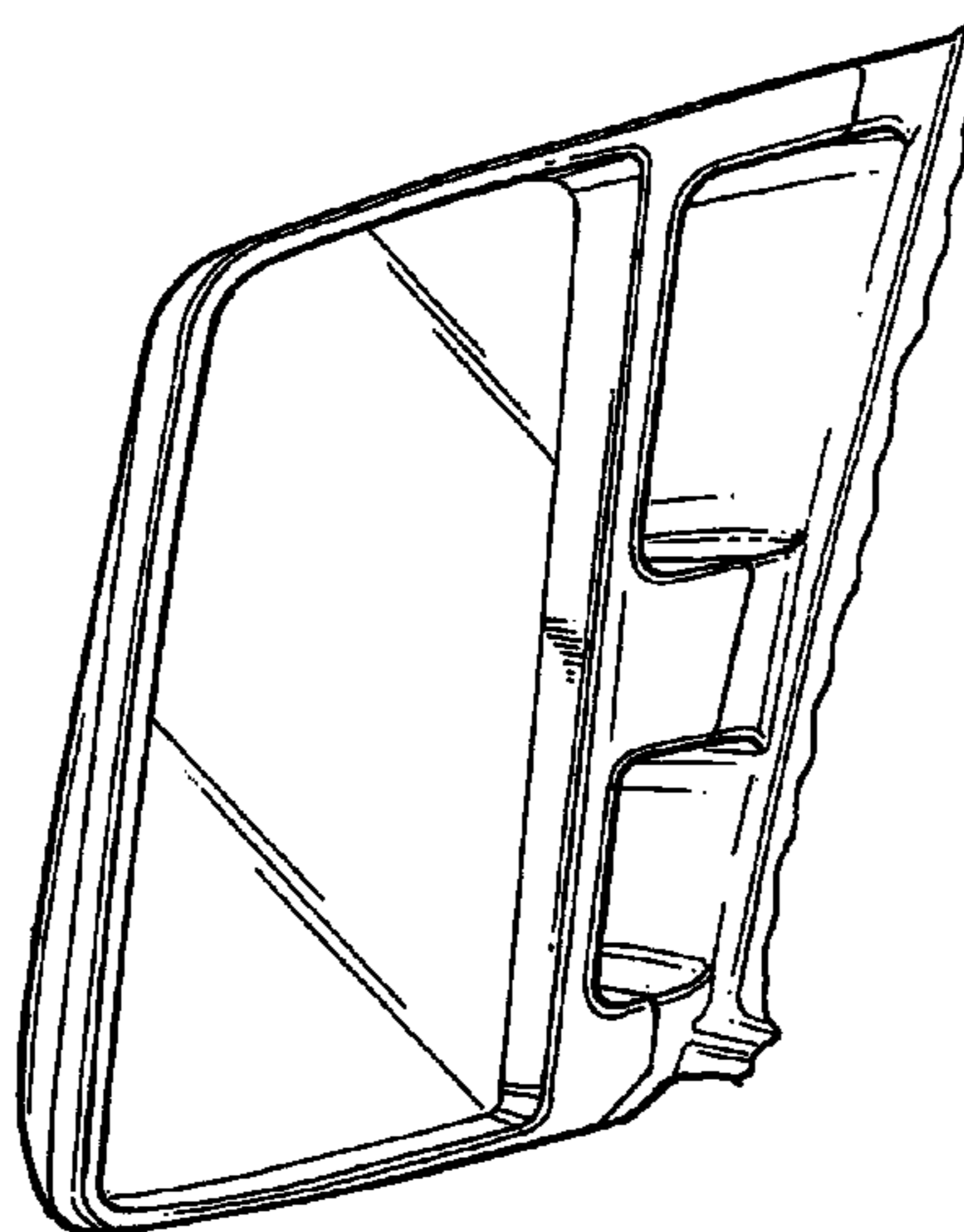

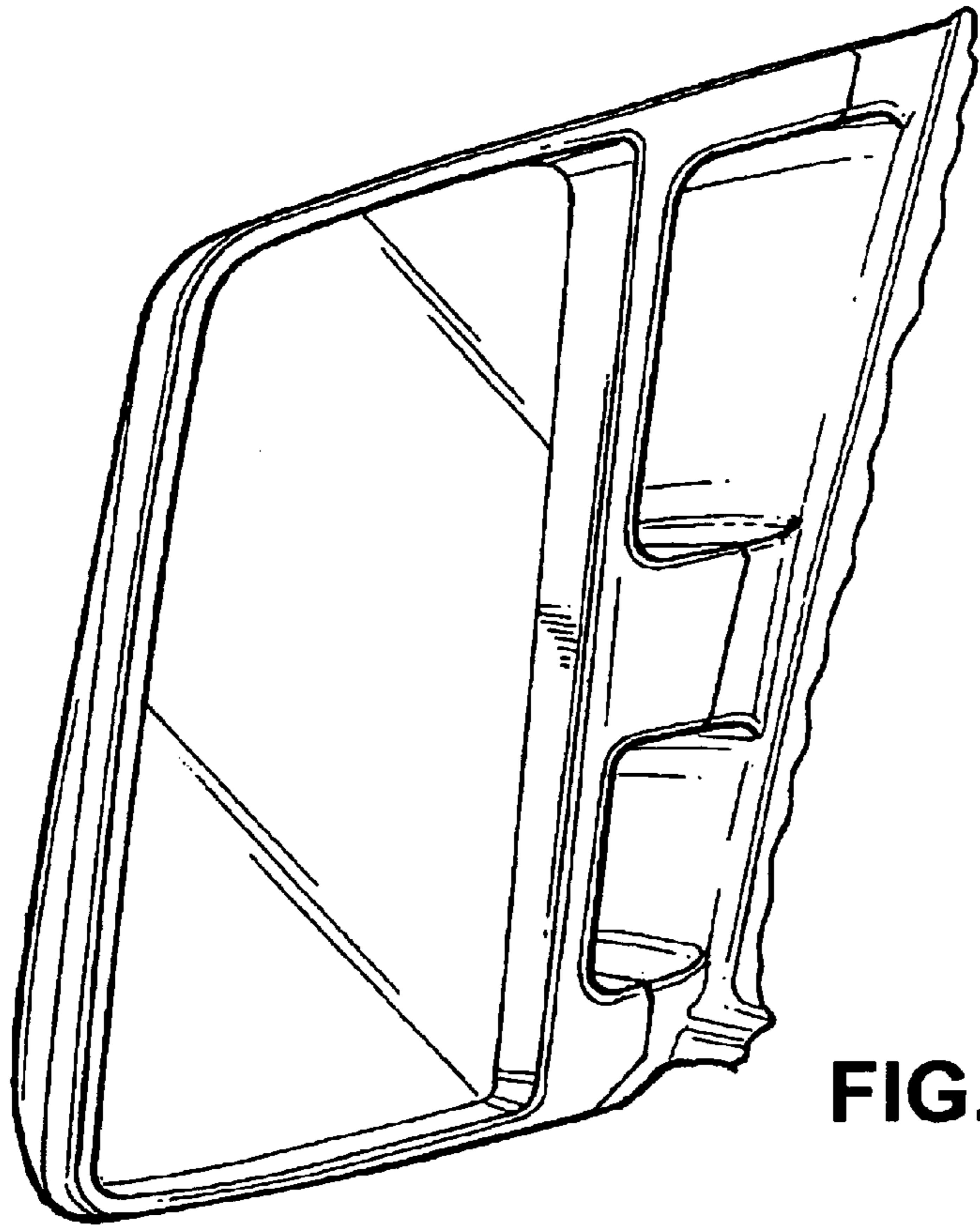

FIG. 1

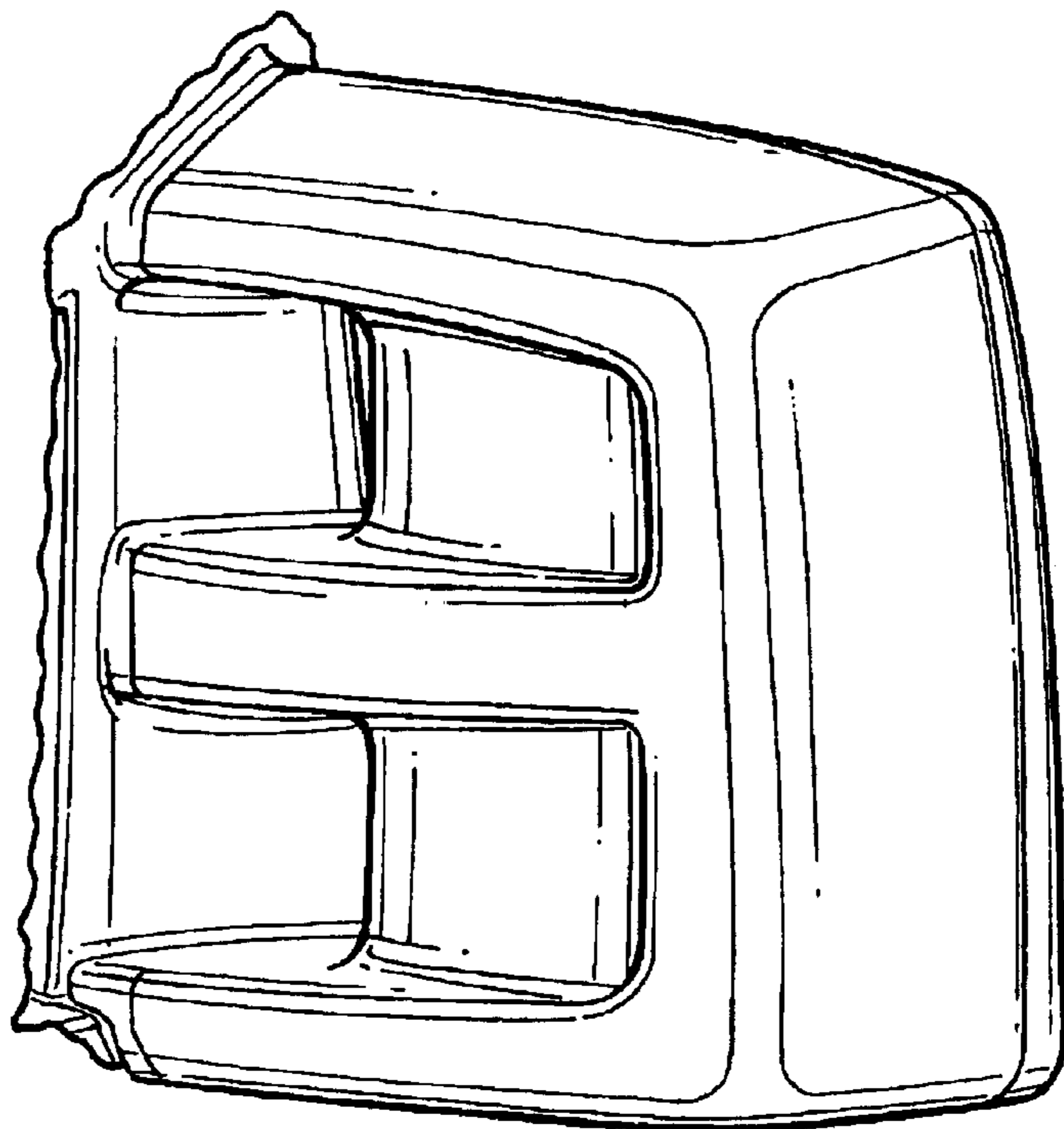

FIG. 2

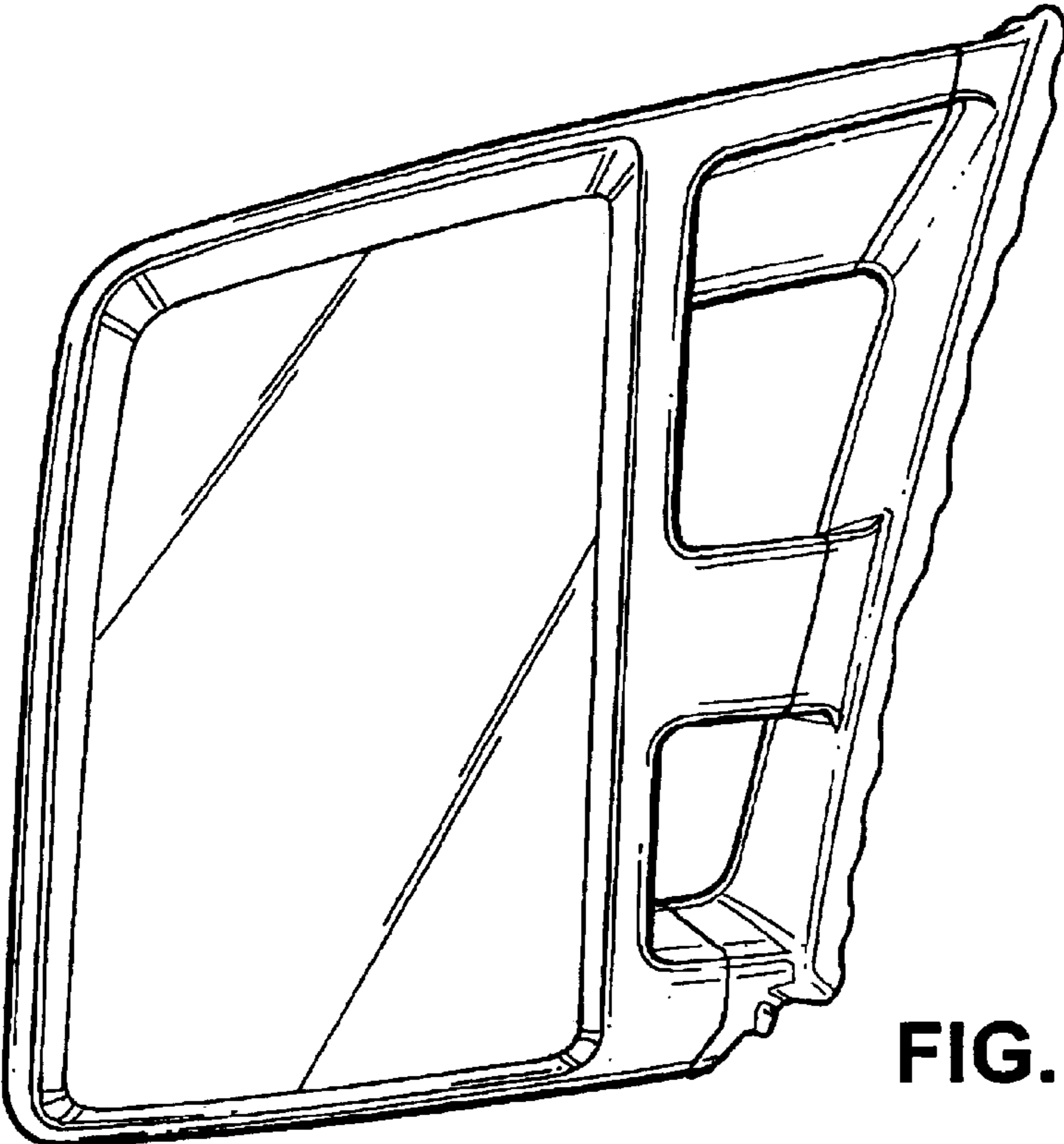

FIG. 3

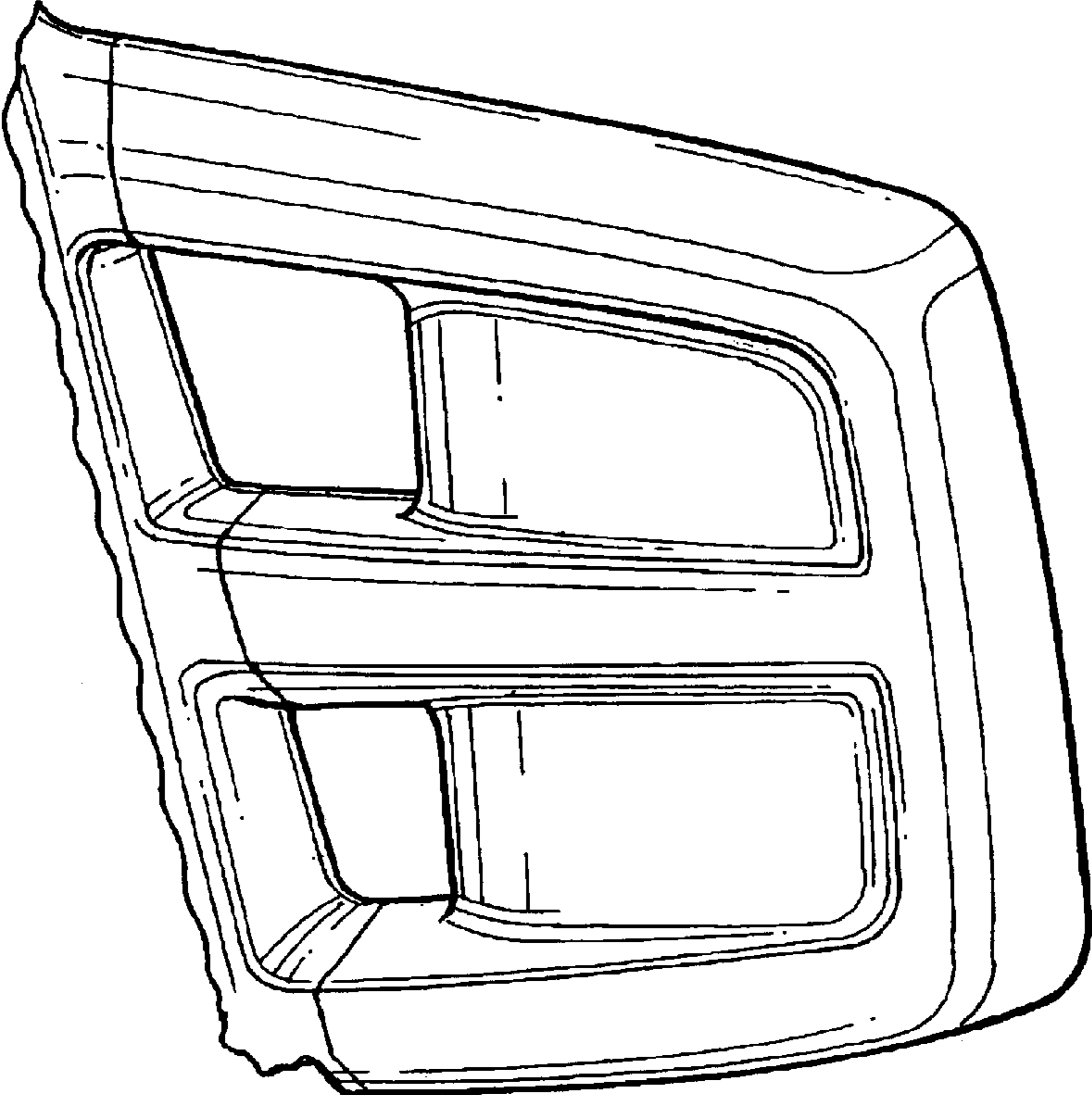

FIG. 4



FIG. 5

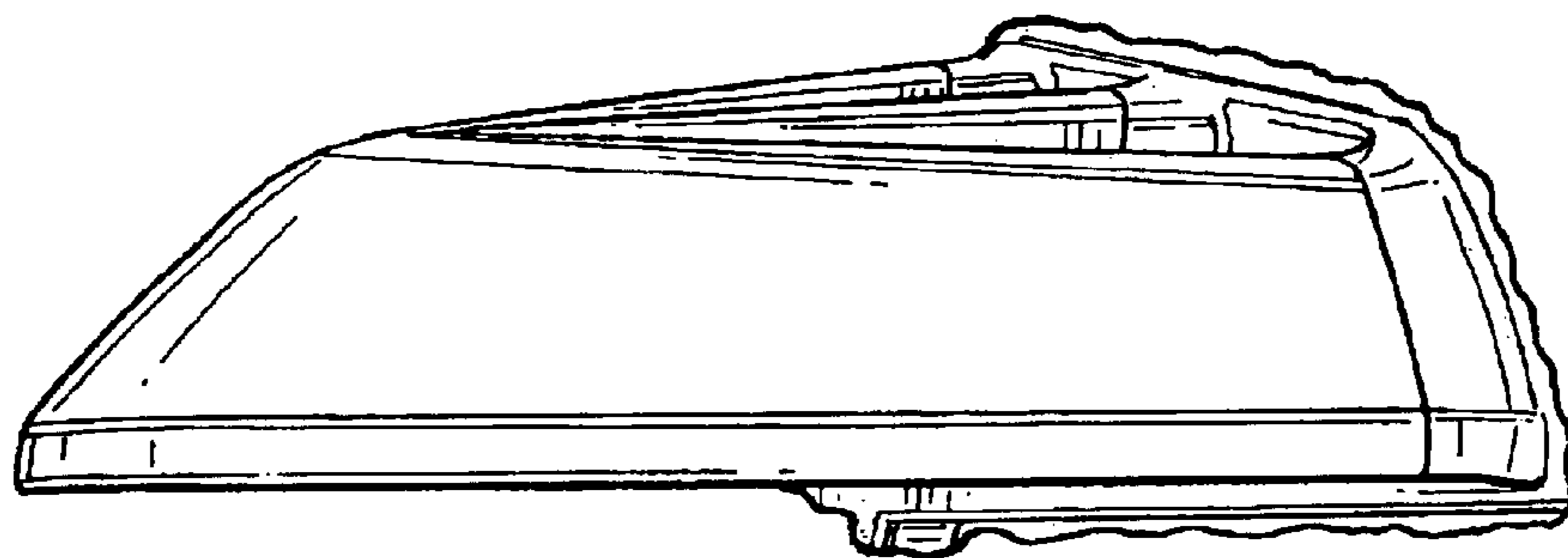

FIG. 6

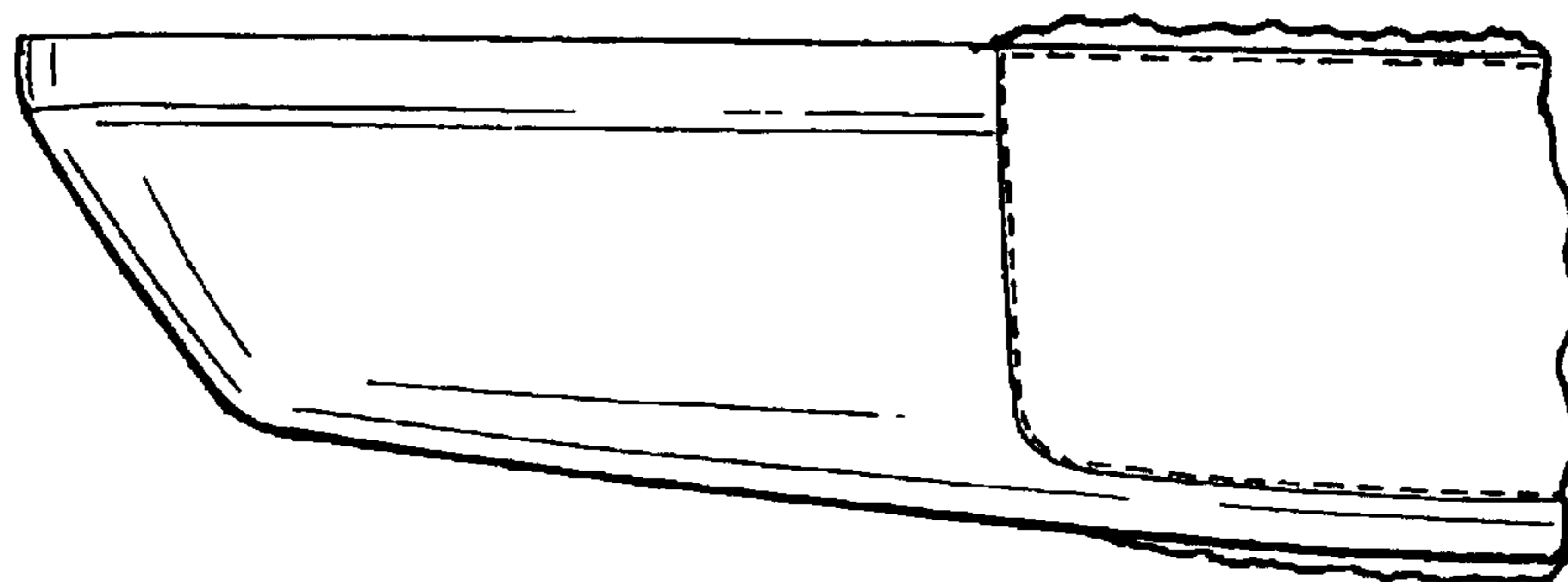

FIG. 7

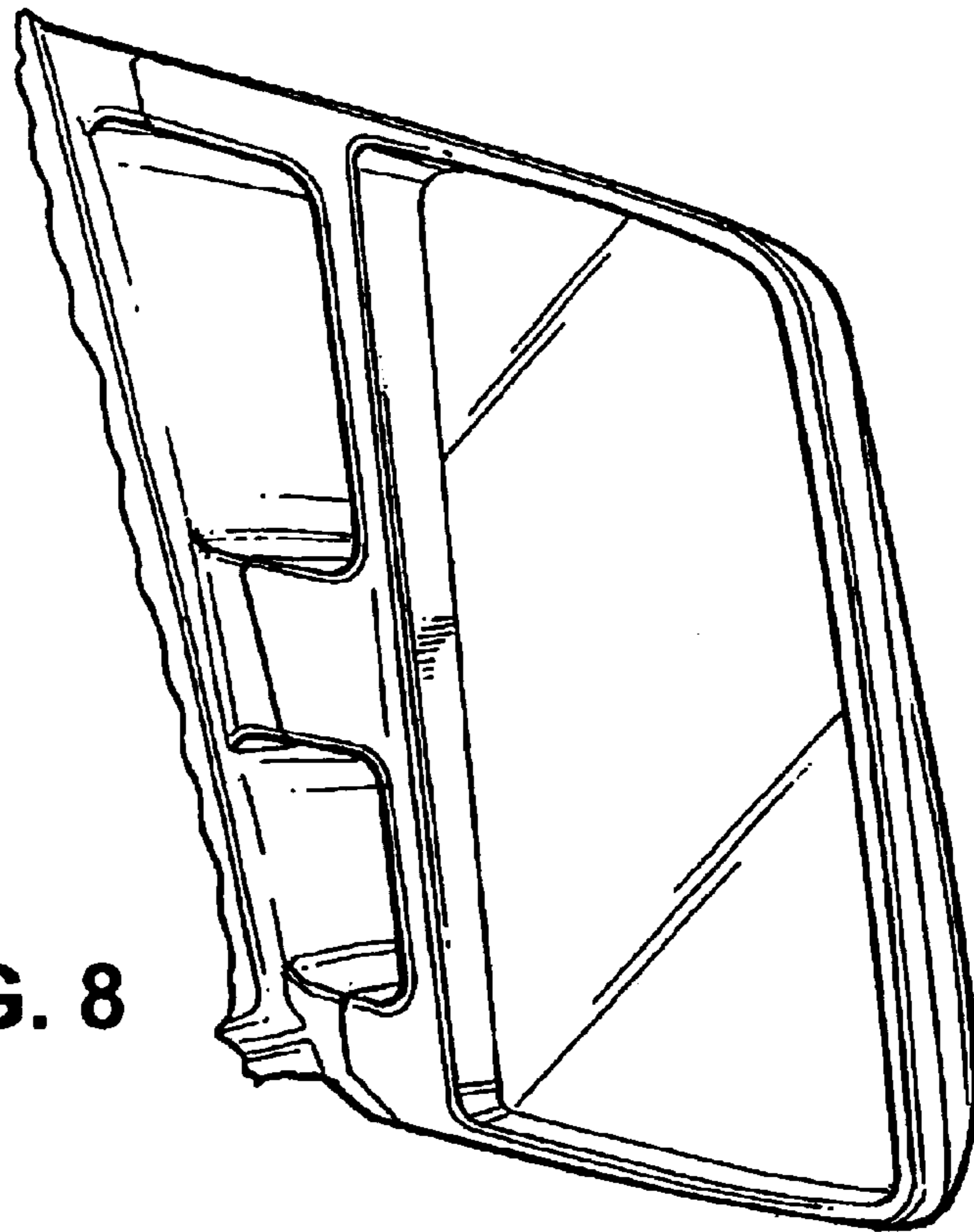

FIG. 8

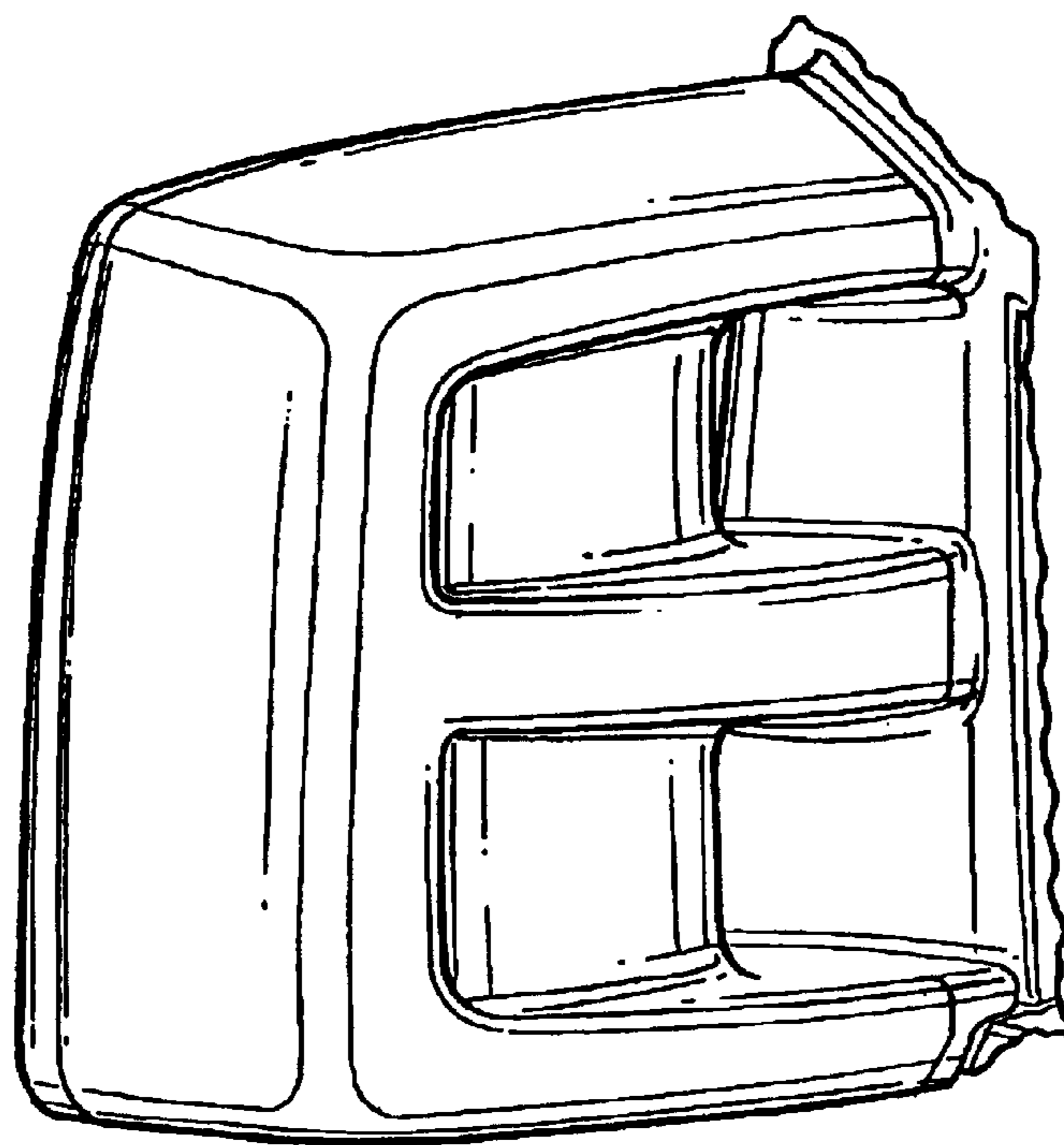

FIG. 9

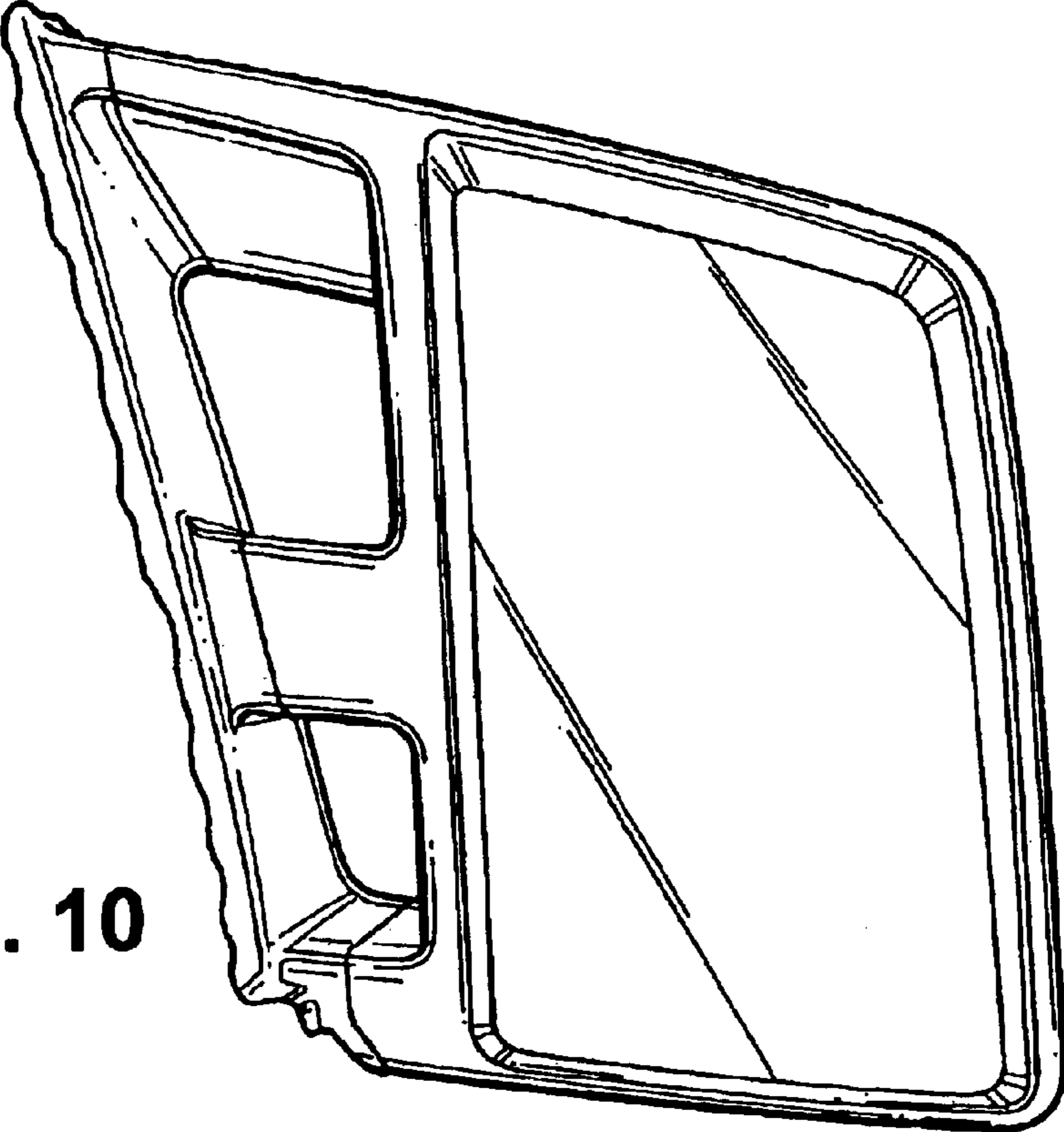

FIG. 10

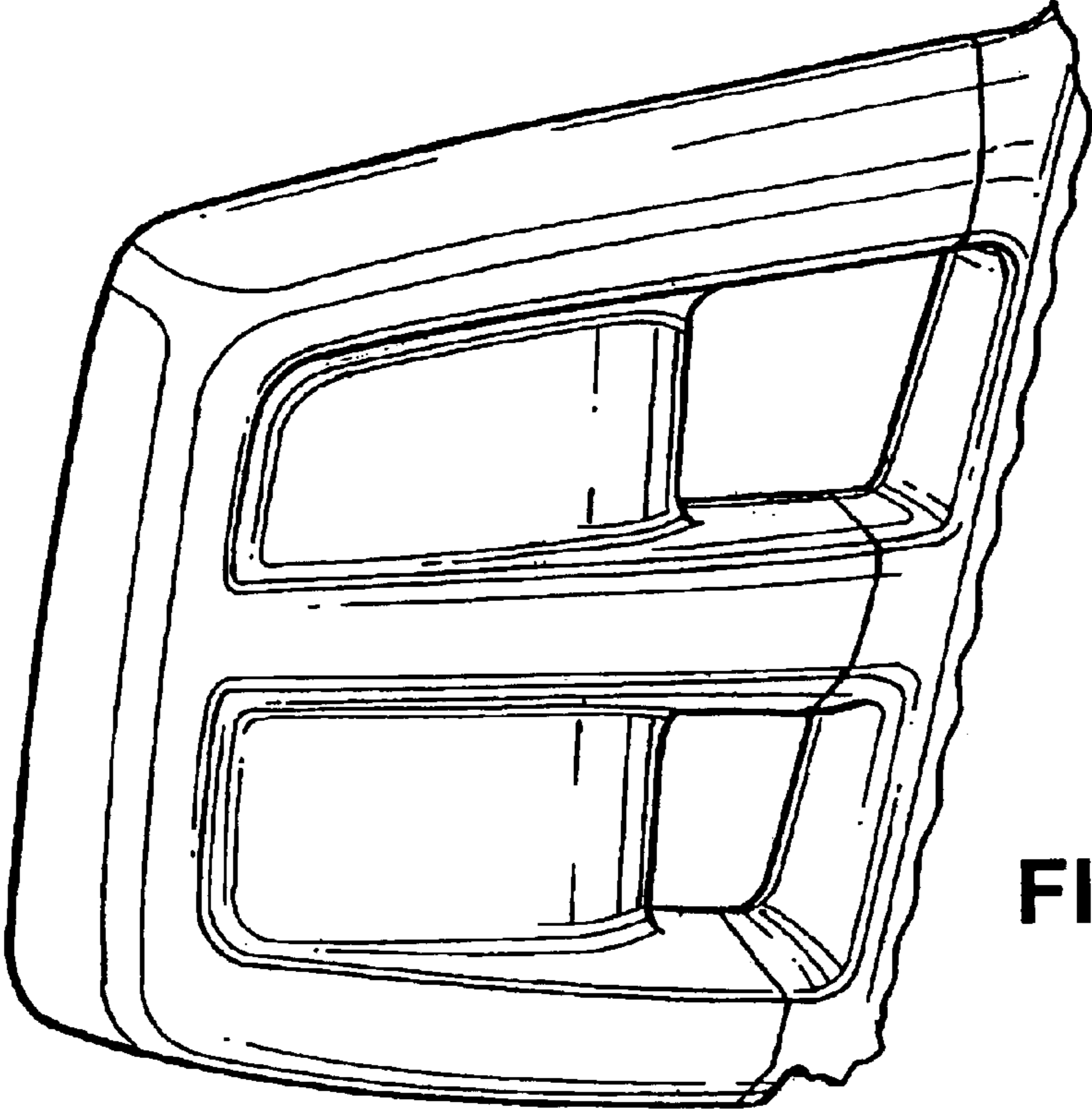

FIG. 11

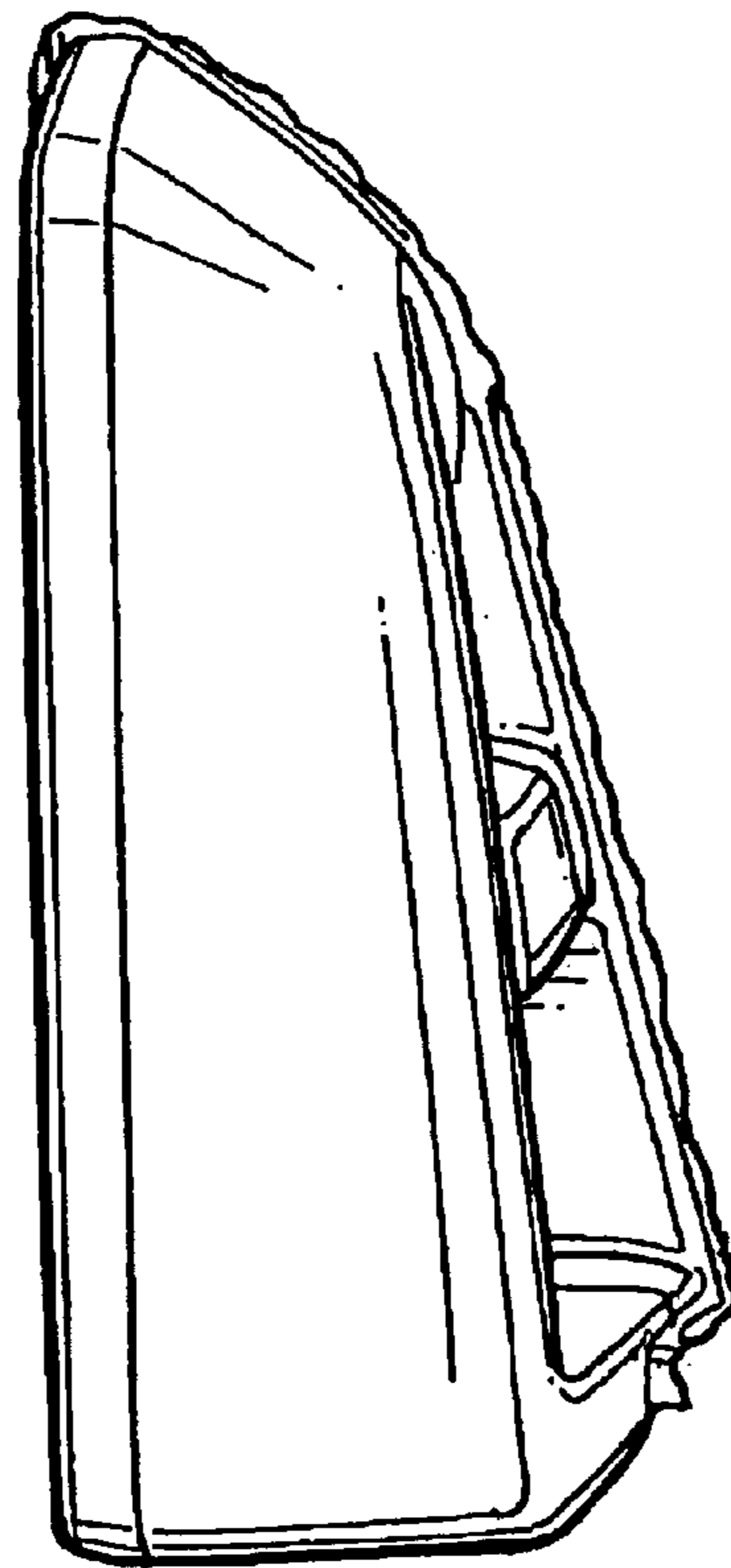

FIG. 12

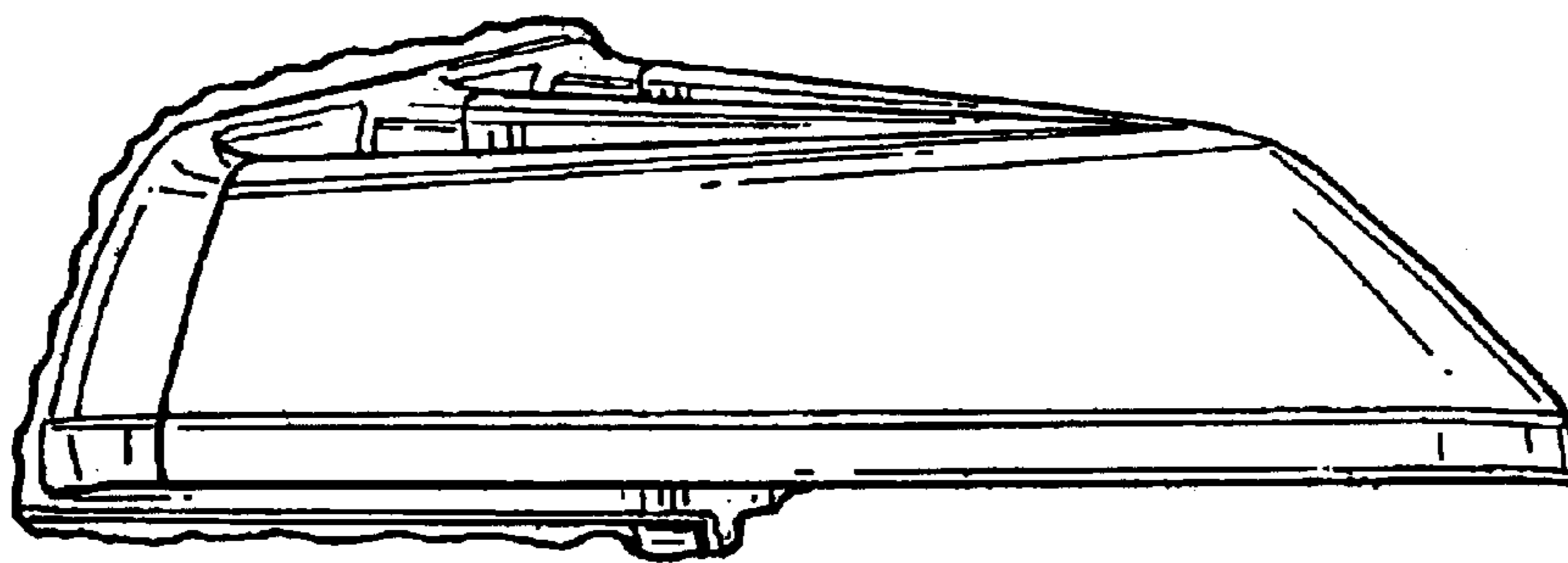

FIG. 13

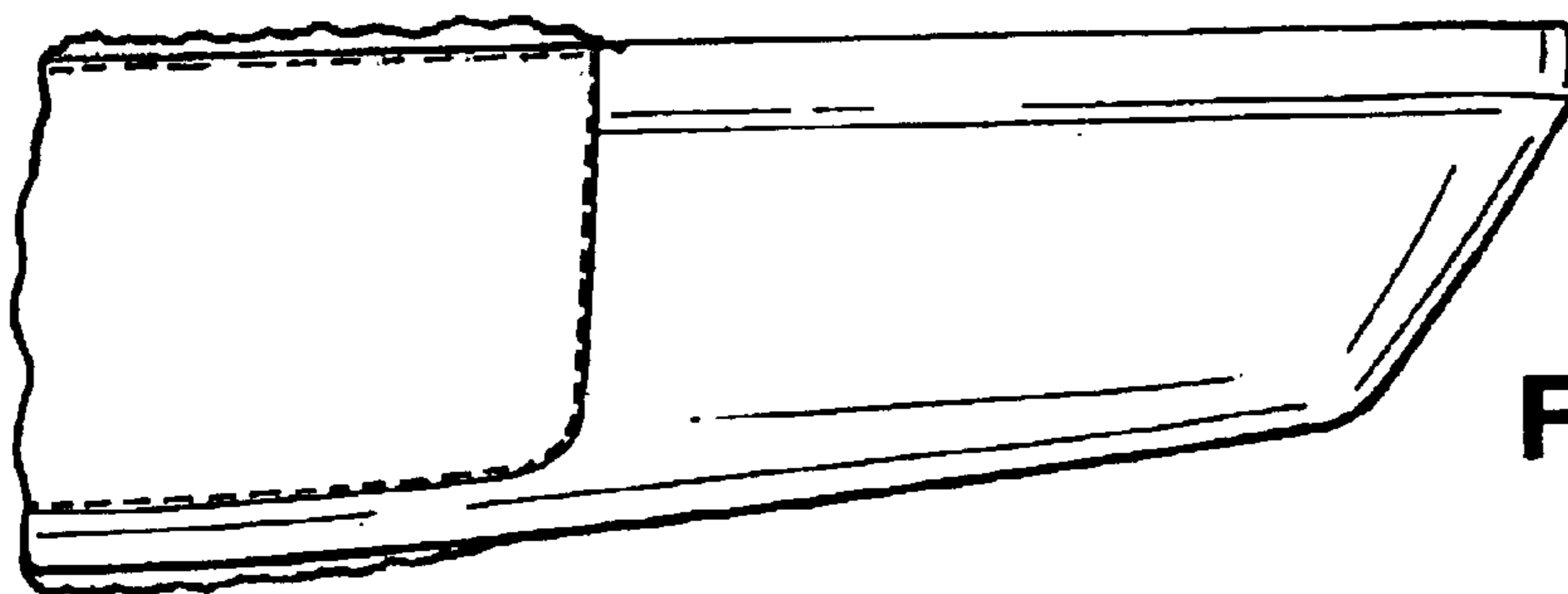

FIG. 14