

US00D499957S

(12) **United States Design Patent** (10) **Patent No.:** **US D499,957 S**
Friedline et al. (45) **Date of Patent:** **** Dec. 21, 2004**

(54) **CONDUIT SUPPORT**

(75) Inventors: **Gary W. Friedline**, New Alexandria, PA (US); **Robert S. Chappo, Jr.**, West Mifflin, PA (US); **Kenneth R. Graham**, Youngwood, PA (US)

(73) Assignee: **PBM, Inc.**, Irwin, PA (US)

(**) Term: **14 Years**

(21) Appl. No.: **29/205,240**

(22) Filed: **May 11, 2004**

Related U.S. Application Data

(63) Continuation of application No. 29/183,857, filed on Jun. 18, 2003, now abandoned.

(51) **LOC (7) Cl.** **08-05**

(52) **U.S. Cl.** **D8/380**

(58) **Field of Search** D8/349, 354, 356, D8/367, 380, 382, 383, 394, 396; D23/265; 174/48, 49, 68.1, 68.3; 248/49, 58, 62, 65, 67.7, 68.1, 71, 74.1, 200, 201

(56) **References Cited**

U.S. PATENT DOCUMENTS

| | | |
|-------------|---------|------------------|
| 824,544 A | 6/1906 | Hossege |
| 1,196,930 A | 9/1916 | Carpenter et al. |
| 1,322,414 A | 11/1919 | Elkins |
| 1,480,147 A | 1/1924 | Brandt |
| 1,906,209 A | 4/1933 | Harding et al. |
| 2,335,296 A | 11/1943 | Miller |
| 2,339,565 A | 1/1944 | Goldberg et al. |
| 2,354,919 A | 8/1944 | Lockwood |
| 2,355,742 A | 8/1944 | Morehouse |
| 2,356,318 A | 8/1944 | Hayman |
| 2,361,943 A | 11/1944 | Issoglio et al. |
| 2,362,124 A | 11/1944 | Ellinwood |
| 2,404,531 A | 7/1946 | Robertson |
| 2,425,033 A | 8/1947 | Fletcher |
| 2,442,833 A | 6/1948 | Watkins |
| 2,676,036 A | 4/1954 | Arrowood |
| D172,741 S | 8/1954 | Cooper |

(List continued on next page.)

OTHER PUBLICATIONS

U.S. Appl. No. 29/183,857, unpublished, Friedline et al.

Primary Examiner—Joel A. Sincavage

Assistant Examiner—Elizabeth Albert

(74) *Attorney, Agent, or Firm*—Kirkpatrick & Lockhart LLP

(57) **CLAIM**

The ornamental design for a conduit support, as shown and described.

DESCRIPTION

FIG. 1 is an isometric elevational view of an embodiment of the conduit support of the new design supporting a conventional conduit, which is shown in broken lines;

FIG. 2 is a front view of the conduit support depicted in FIG. 1;

FIG. 3 is a left side elevational view of the conduit support depicted in FIG. 1 with the right side elevational view being a mirror image thereof;

FIG. 4 is a top view of the conduit support of FIG. 1;

FIG. 5 is a bottom view of the conduit support of FIG. 1;

FIG. 6 is an isometric elevational view of another embodiment of the conduit support of the new design;

FIG. 7 is a front view of the conduit support depicted in FIG. 6;

FIG. 8 is a left side elevational view of the conduit support depicted in FIG. 6 with the right side elevational view being a mirror image thereof;

FIG. 9 is a top view of the conduit support depicted in FIG. 6; and,

FIG. 10 is a bottom view of the conduit support depicted in FIG. 6.

The broken lines showing conduits, nuts, washers and support members in FIGS. 1–10 depict an environment for illustrative purposes only and form no part of the claimed design.

1 Claim, 2 Drawing Sheets

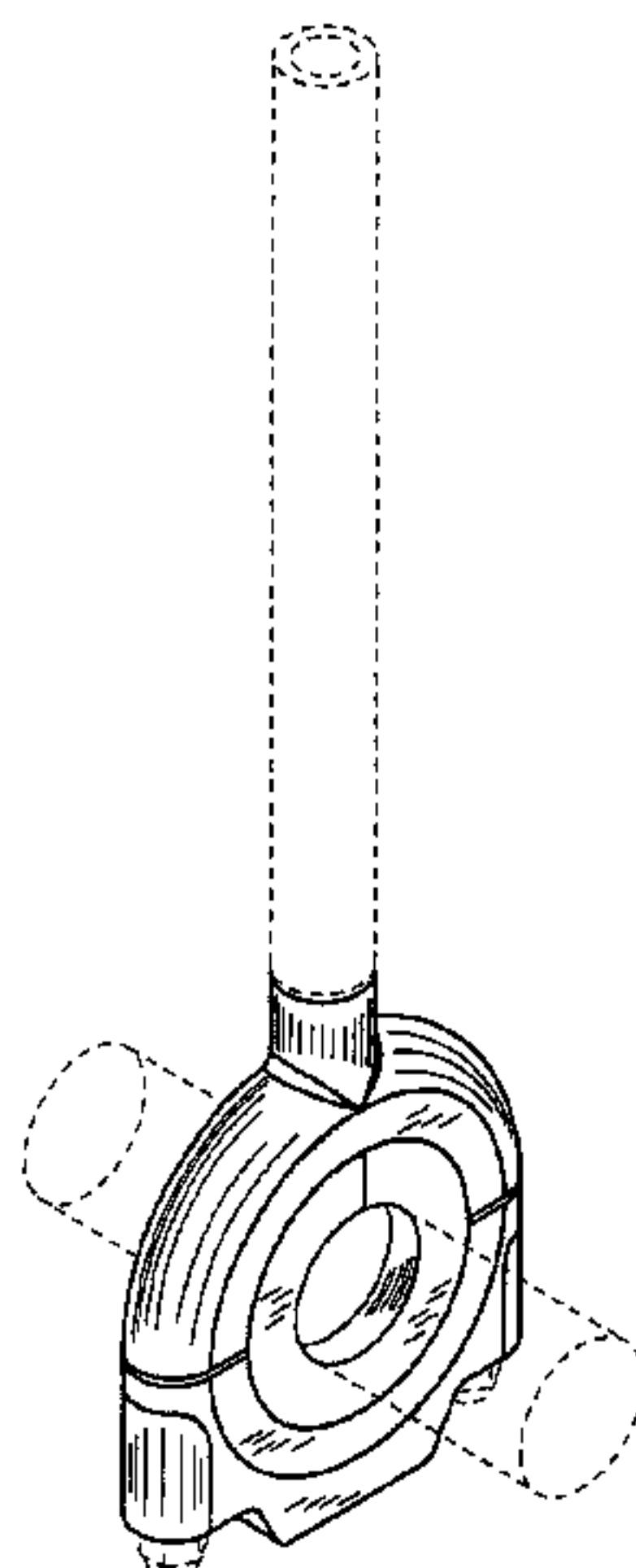

| U.S. PATENT DOCUMENTS | | | | | |
|-----------------------|---------|---------------------|-----------------|---------|---------------------------|
| 2,712,167 A | 7/1955 | Blanchard | 5,014,940 A | 5/1991 | Sherman |
| 2,861,762 A | 11/1958 | Gunthel, Jr. | 5,098,047 A | 3/1992 | Plumley |
| 2,890,848 A | 6/1959 | Johnson, Jr. | 5,112,031 A | 5/1992 | Hynds et al. |
| 2,937,835 A | 5/1960 | Csmereka | 5,192,039 A | 3/1993 | Williams |
| D190,680 S | 6/1961 | Sakhnoffsky | 5,221,064 A | 6/1993 | Hodges |
| 3,128,073 A | 4/1964 | Berlyn | 5,240,294 A | 8/1993 | Corcoran |
| 3,186,051 A | 6/1965 | Waddell | 5,271,588 A | 12/1993 | Doyle |
| 3,188,030 A | 6/1965 | Fischer | 5,350,141 A | 9/1994 | Perrault et al. |
| 3,244,388 A | 4/1966 | Coffman | 5,377,939 A | 1/1995 | Kirma |
| 3,266,761 A | 8/1966 | Walton et al. | 5,381,833 A | 1/1995 | Cummings et al. |
| 3,273,837 A | 9/1966 | Willert et al. | 5,395,079 A | 3/1995 | Jensen et al. |
| 3,523,667 A | 8/1970 | Guerrero | 5,443,232 A | 8/1995 | Kesinger et al. |
| 3,530,899 A | 9/1970 | Breeding | 5,503,353 A | 4/1996 | Degand |
| 3,531,071 A | 9/1970 | Kubli | 5,542,631 A | 8/1996 | Bruno |
| 3,539,137 A | 11/1970 | March | 5,553,975 A | 9/1996 | Elkins |
| 3,572,662 A | 3/1971 | Weaver | 5,593,115 A | 1/1997 | Lewis |
| 3,582,029 A | 6/1971 | Moesta | 5,651,519 A | 7/1997 | Goodrich et al. |
| 3,695,563 A | 10/1972 | Evans | 5,794,897 A | 8/1998 | Jobin et al. |
| 3,848,839 A | 11/1974 | Tillman | 5,865,474 A | 2/1999 | Takahashi |
| 3,851,979 A | 12/1974 | Becker | 5,876,000 A | 3/1999 | Ismert |
| 3,856,246 A | 12/1974 | Sinko | D408,727 S | 4/1999 | Sherman |
| 3,914,100 A | 10/1975 | Guskea | 5,906,341 A | 5/1999 | Brown |
| 3,944,175 A | 3/1976 | Kearney | 5,931,423 A | 8/1999 | Heideloff |
| 4,004,766 A | 1/1977 | Long | 5,971,663 A | 10/1999 | Brothers |
| 4,025,131 A | 5/1977 | Bergquist et al. | 5,979,839 A | 11/1999 | Horn et al. |
| D247,420 S | 3/1978 | Reynolds | 5,984,243 A | 11/1999 | Pfaller et al. |
| 4,121,796 A | 10/1978 | Forbes | 5,992,802 A | 11/1999 | Campbell |
| 4,134,563 A | 1/1979 | Pollono | D422,204 S | 4/2000 | Holloway et al. |
| 4,146,203 A | 3/1979 | Williams | 6,079,673 A | 6/2000 | Cox |
| 4,202,520 A | 5/1980 | Loos et al. | 6,105,216 A | 8/2000 | Opperthausen |
| 4,262,869 A | 4/1981 | Menshen | 6,126,122 A | 10/2000 | Ismert |
| 4,270,250 A | 6/1981 | Schön | 6,142,428 A | 11/2000 | Kamata et al. |
| D263,415 S * | 3/1982 | Roche D23/265 | 6,146,050 A | 11/2000 | Marshall |
| 4,411,460 A | 10/1983 | Beal | 6,161,589 A | 12/2000 | Bolotte et al. |
| 4,415,188 A | 11/1983 | Ginter, Jr. | D436,028 S * | 1/2001 | Wagner et al. D8/396 |
| 4,444,370 A | 4/1984 | Krueger | 6,301,735 B1 | 10/2001 | Jartoux et al. |
| D273,938 S | 5/1984 | Piper | 6,349,807 B1 | 2/2002 | Northup et al. |
| 4,595,162 A | 6/1986 | Matsumura et al. | 6,431,502 B1 * | 8/2002 | Goodman 248/74.1 |
| 4,618,114 A | 10/1986 | McFarland | 2002/0000499 A1 | 1/2002 | Aoki et al. |
| 4,666,109 A | 5/1987 | Fallon et al. | 2002/0030144 A1 | 3/2002 | Blane et al. |
| 4,765,577 A | 8/1988 | Collins et al. | 2002/0066835 A1 | 6/2002 | Sentpall et al. |
| 4,784,363 A | 11/1988 | Brown et al. | 2002/0104930 A1 | 8/2002 | Attee |
| 4,858,860 A | 8/1989 | Richards | 2002/0113173 A1 | 8/2002 | Bass |
| D309,094 S | 7/1990 | Donis et al. | 2002/0153459 A1 | 10/2002 | Maurice |
| 5,007,604 A | 4/1991 | Richards | 2002/0158171 A1 | 10/2002 | Karlinger |

* cited by examiner

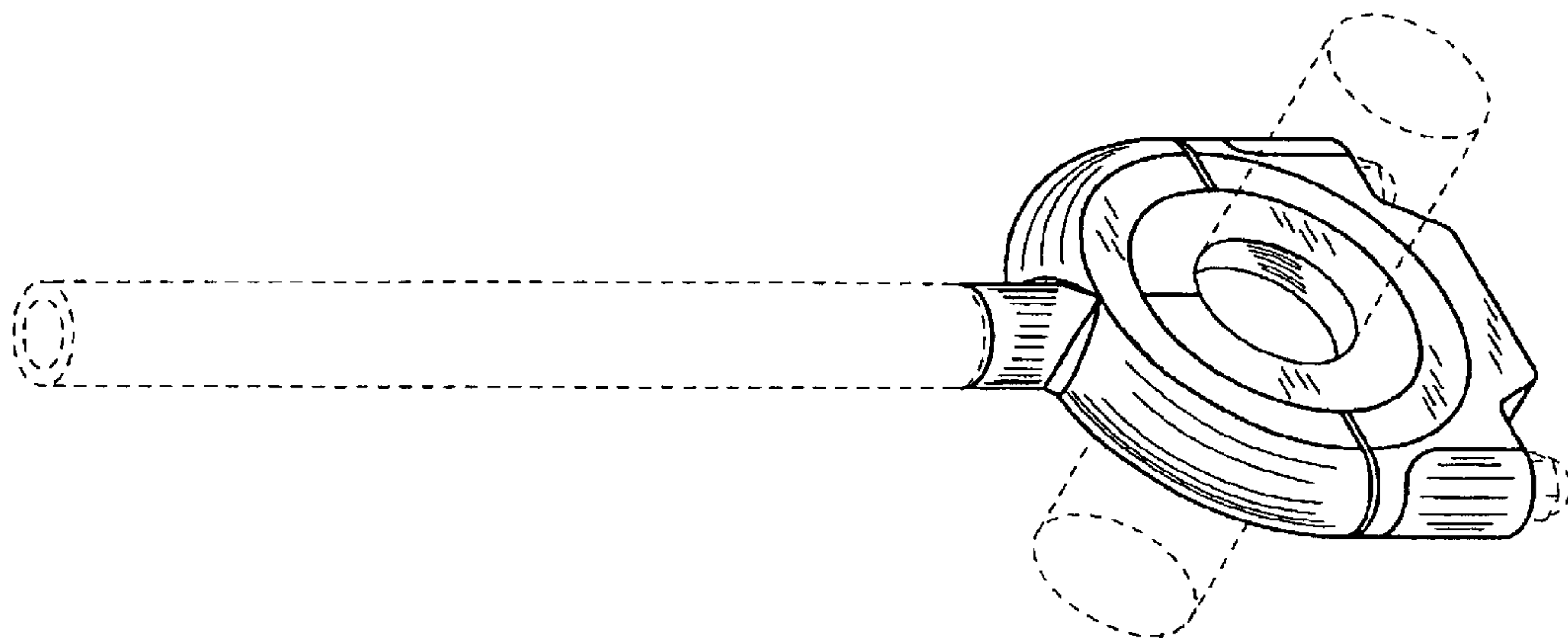

FIG. 1



FIG. 4



FIG. 5

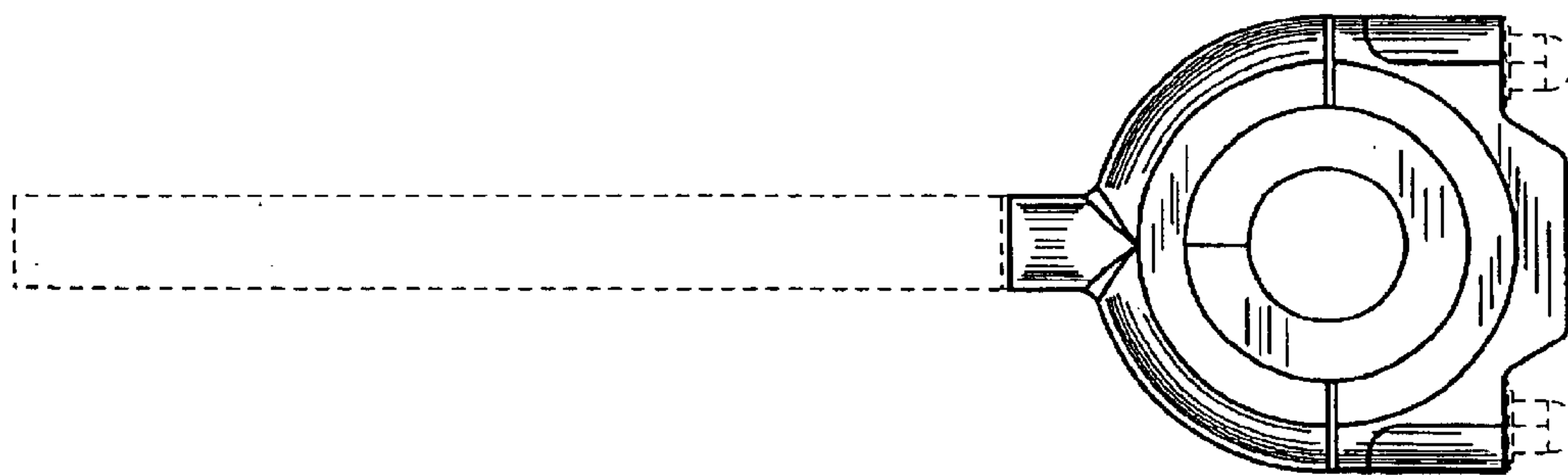

FIG. 2



FIG. 3

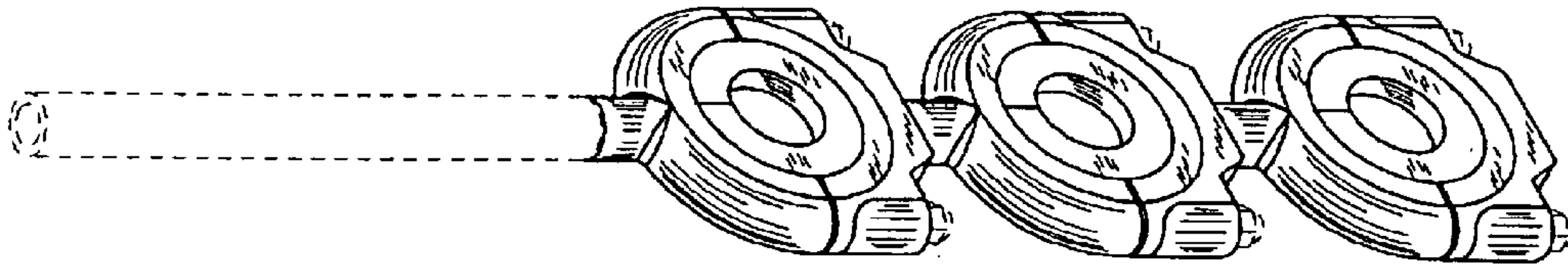

FIG. 6



FIG. 9



FIG. 10

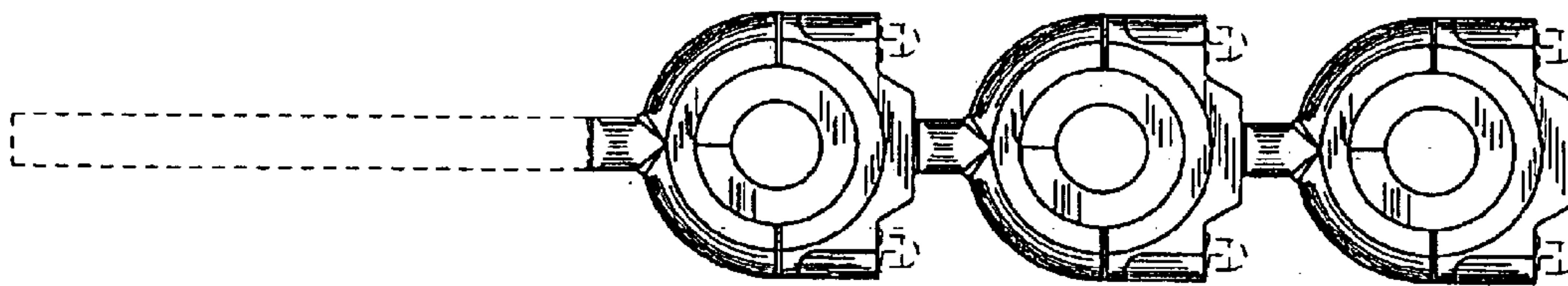

FIG. 7



FIG. 8