

US00D499854S

(12) **United States Design Patent** (10) **Patent No.:** **US D499,854 S**  
**Ryan et al.** (45) **Date of Patent:** **\*\* Dec. 14, 2004**

(54) **LOAD BACK REST FOR A MATERIAL HANDLING VEHICLE**

(75) Inventors: **H. Scott Ryan**, Skaneateles, NY (US); **Douglas M. Russell**, Syracuse, NY (US); **David L. Fergot**, Syracuse, NY (US); **Gregory L. Holland**, Endicott, NY (US)

(73) Assignee: **The Raymond Corporation**, Greene, NY (US)

(\*\*) Term: **14 Years**

(21) Appl. No.: **29/189,670**

(22) Filed: **Sep. 9, 2003**

(51) **LOC (7) Cl.** ..... **12-05**

(52) **U.S. Cl.** ..... **D34/34**

(58) **Field of Search** ..... D34/28, 34-35; 180/315; 280/43.12; 187/224, 222; 414/685, 679, 294

(56) **References Cited**

**U.S. PATENT DOCUMENTS**

D407,177 S \* 3/1999 Henshaw et al. .... D34/34  
5,890,562 A \* 4/1999 Bartels et al. .... 187/224

**OTHER PUBLICATIONS**

Harrison Equipment Company, Inc., p. 78, load back, items a and b located at top of page, Jan. 25, 2001.\*

\* cited by examiner

*Primary Examiner*—Holly Baynham

(74) *Attorney, Agent, or Firm*—Quarles & Brady LLP

(57) **CLAIM**

The ornamental design for a load back rest for a material handling vehicle, as shown and described.

**DESCRIPTION**

In a preferred embodiment, the nature of this product is as a load back rest useful in connection with a material handling vehicle.

FIG. 1 is a top, right, front perspective view of a load back rest for a material handling vehicle embodying our new design;

FIG. 2 is a front elevational view of the load back rest shown in FIG. 1;

FIG. 3 is right side elevational view of the load back rest shown in FIG. 1;

FIG. 4 is a top plan view of the load back rest shown in FIG. 1;

FIG. 5 is a bottom plan view of the load back rest shown in FIG. 1;

FIG. 6 is a top, right, front perspective view of a second embodiment of a load back rest for a material handling vehicle embodying our new design;

FIG. 7 is a front elevational view of the load back rest shown in FIG. 6;

FIG. 8 is right side elevational view of the load back rest shown in FIG. 6;

FIG. 9 is a top plan view of the load back rest shown in FIG. 6;

FIG. 10 is a bottom plan view of the load back rest shown in FIG. 6;

FIG. 11 is a top, right, front perspective view of a third embodiment of a load back rest for a material handling vehicle embodying our new design;

FIG. 12 is a front elevational view of the load back rest shown in FIG. 11;

FIG. 13 is right side elevational view of the load back rest shown in FIG. 11;

FIG. 14 is a top plan view of the load back rest shown in FIG. 11; and,

FIG. 15 is a bottom plan view of the load back rest shown in FIG. 11.

The broken line representations of portions of the load back rest and material handling vehicle in FIGS. 1-15, are for the purpose of illustration only, and form no part of the claimed design.

**1 Claim, 6 Drawing Sheets**

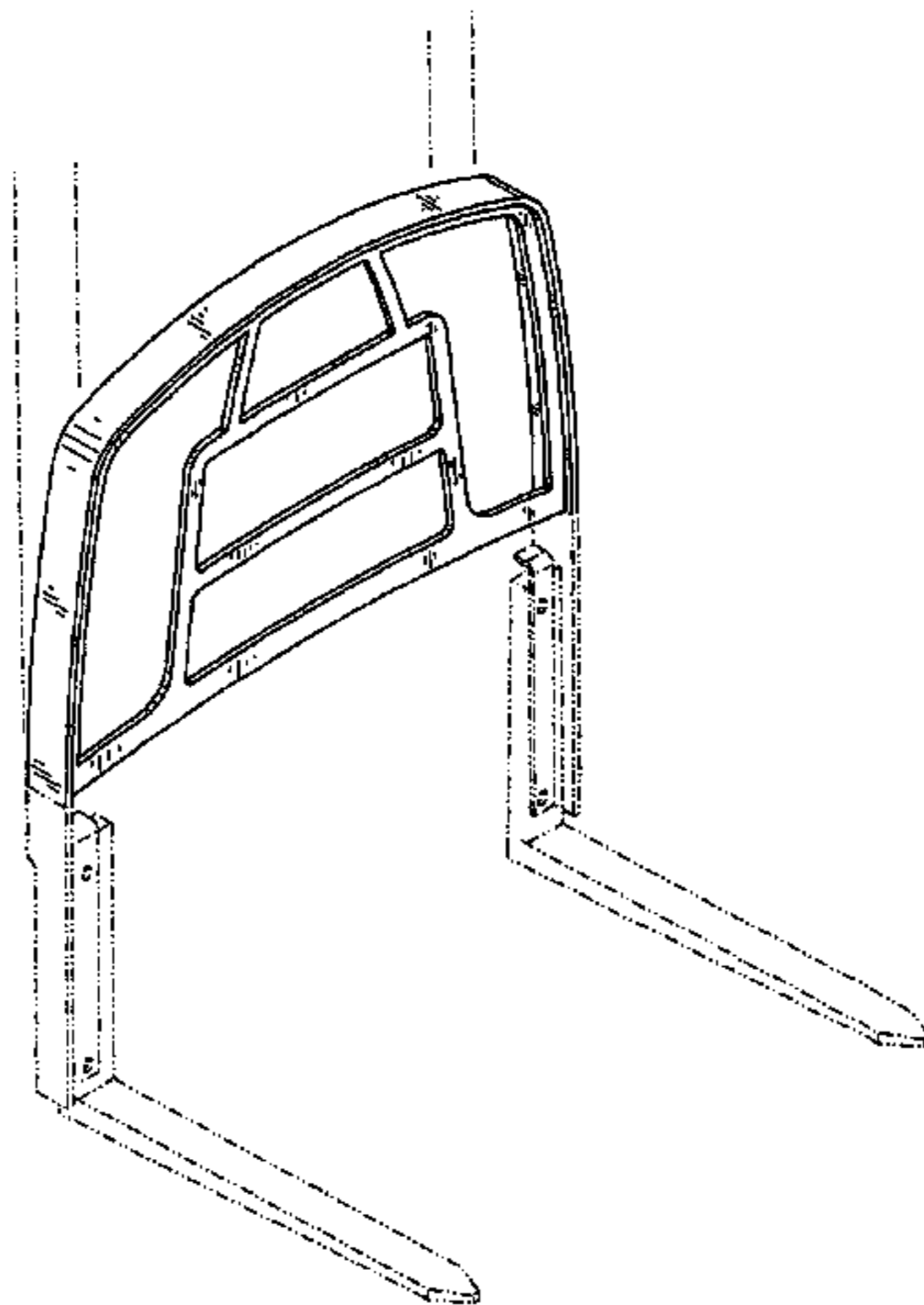

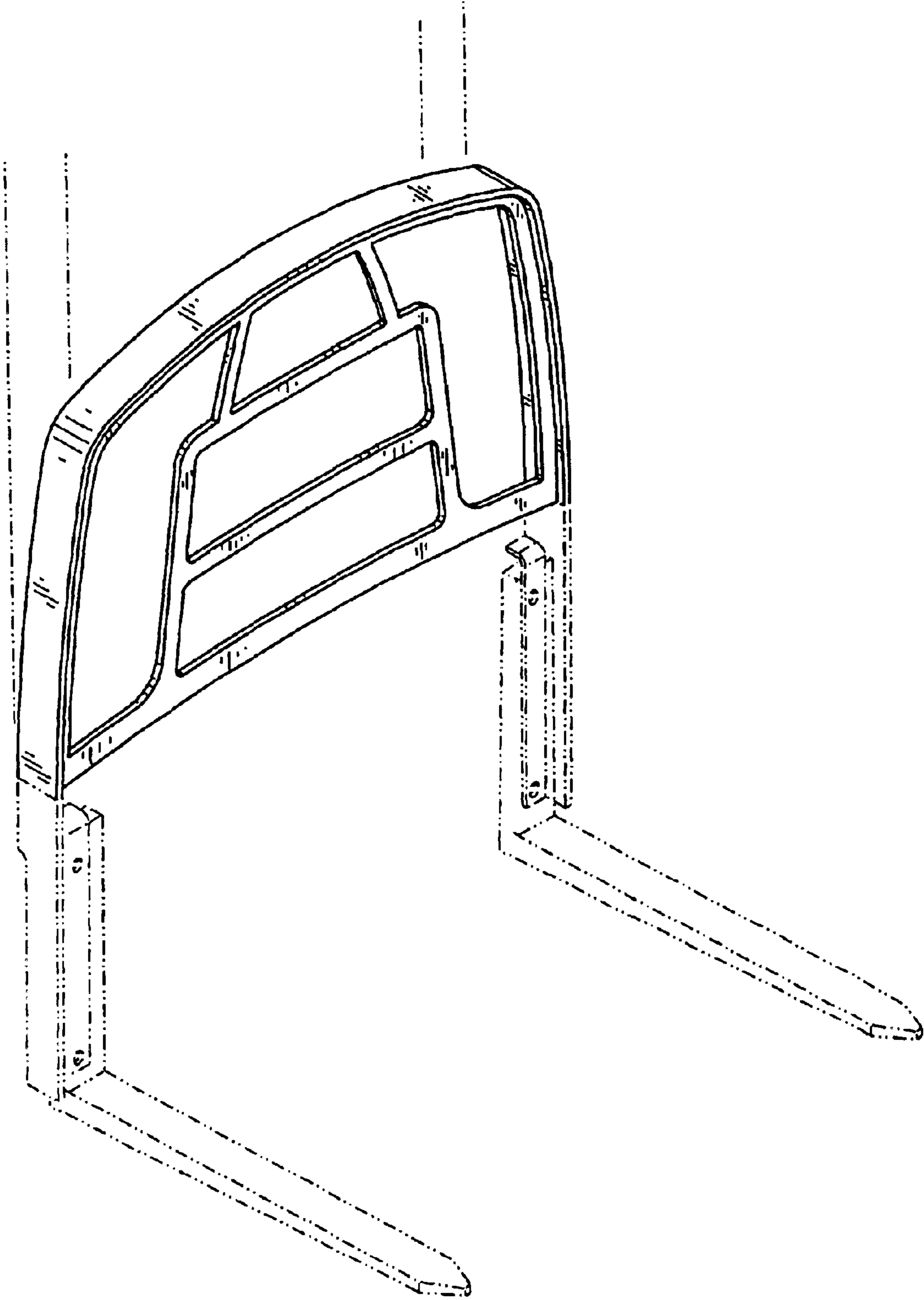

FIG. 1

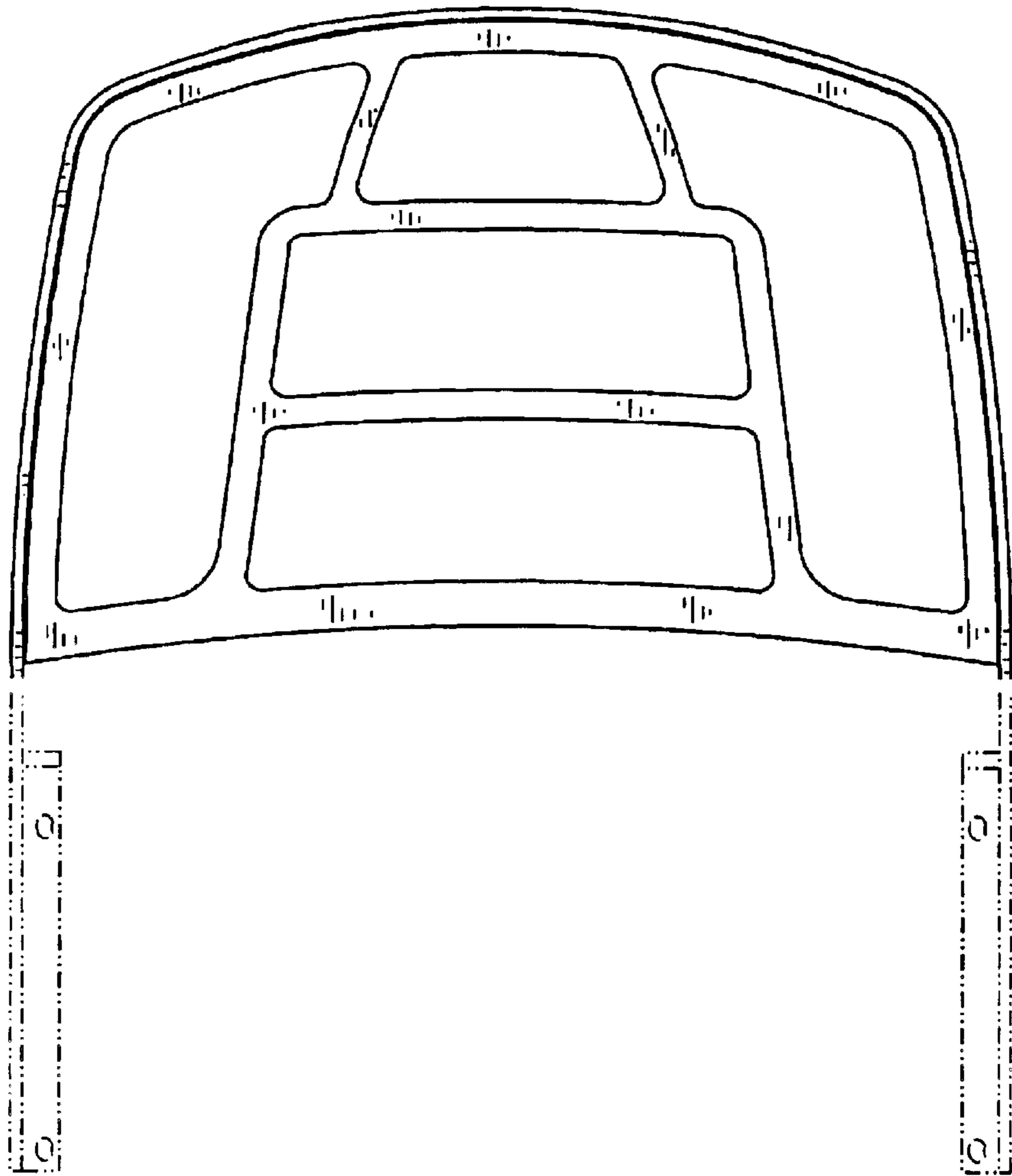

FIG. 2



FIG. 3



FIG. 4

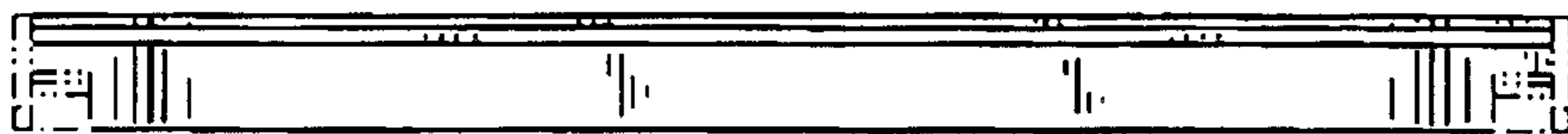

FIG. 5

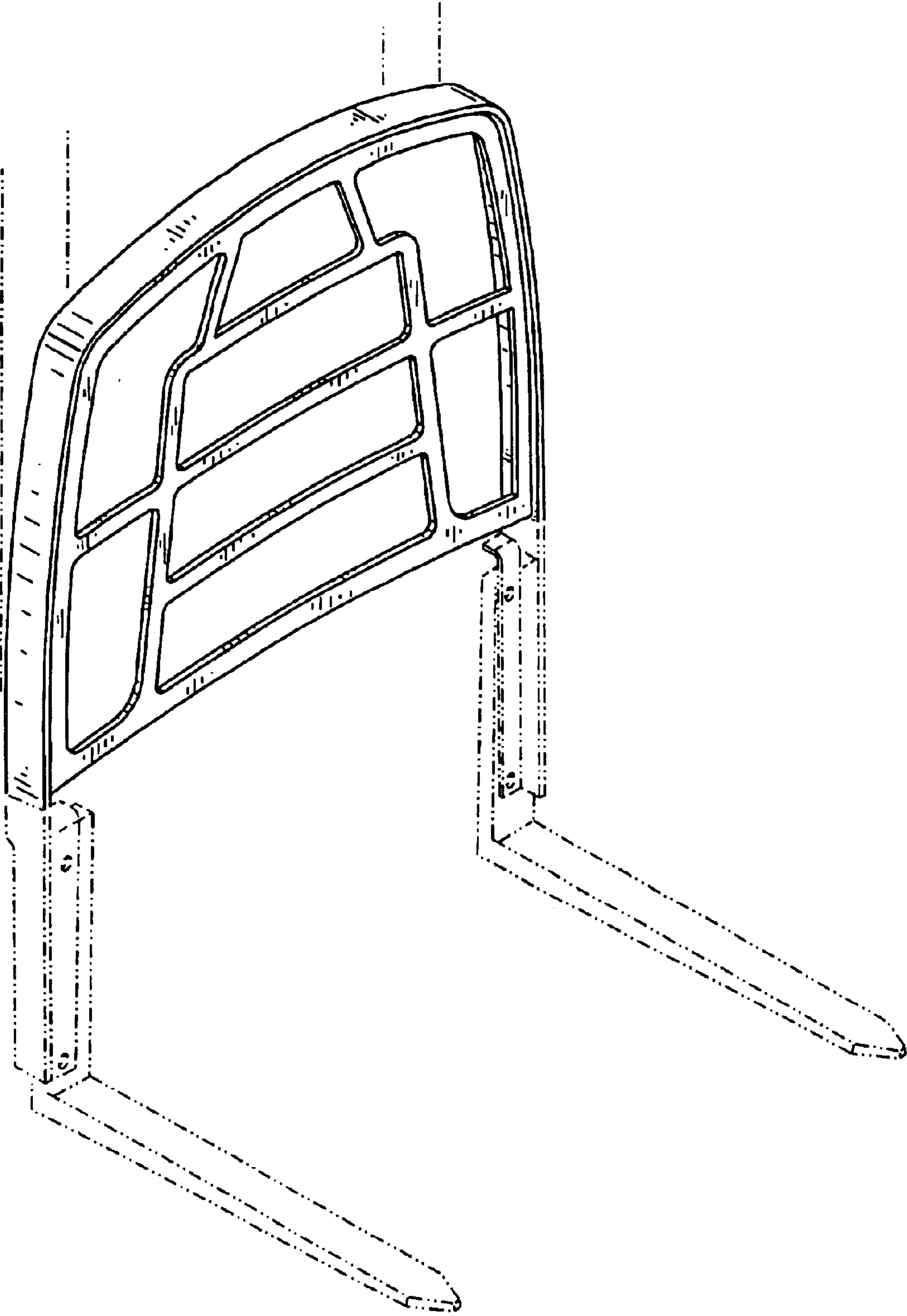

FIG. 6

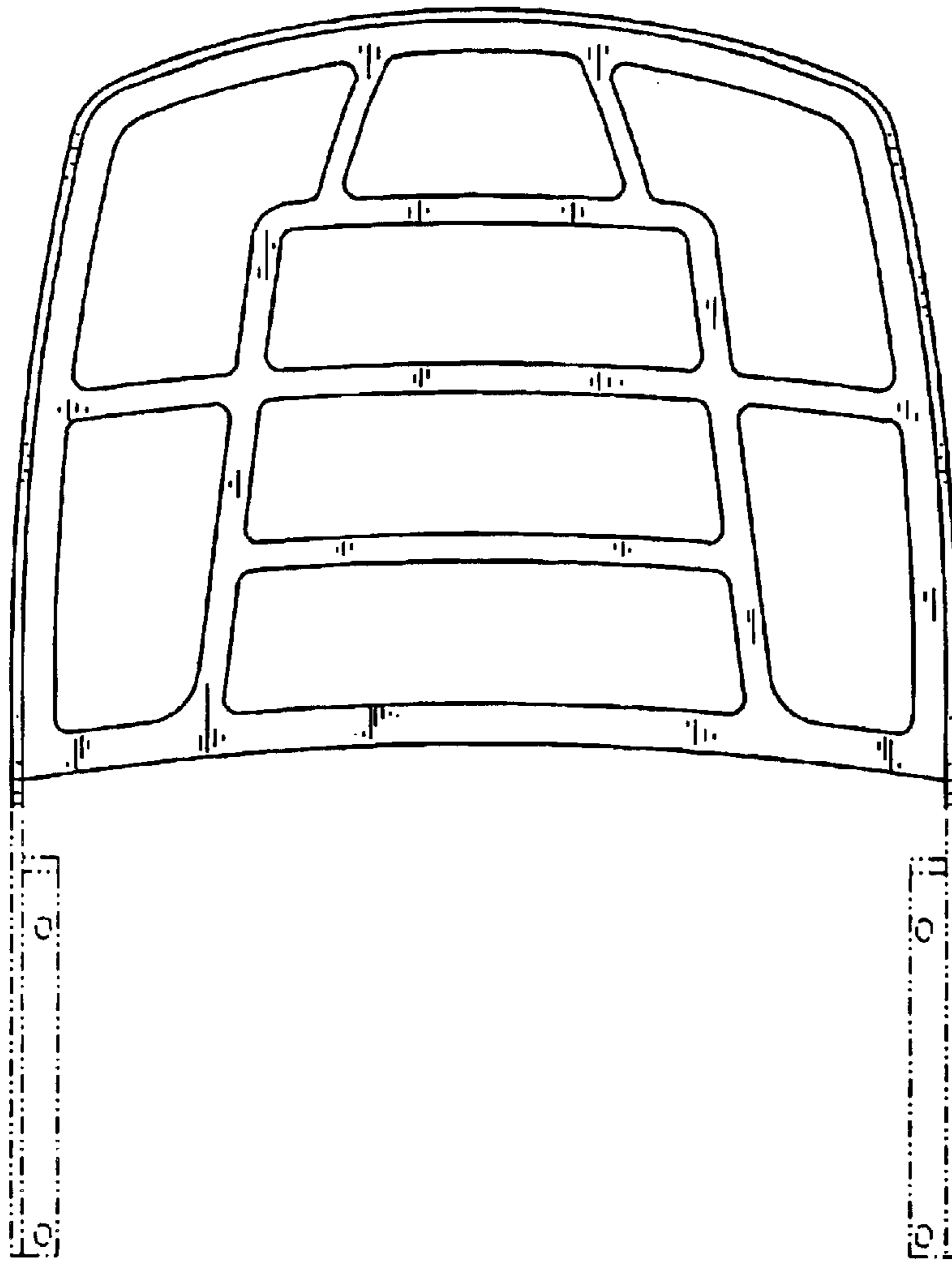

FIG. 7



FIG. 8



FIG. 9



FIG. 10

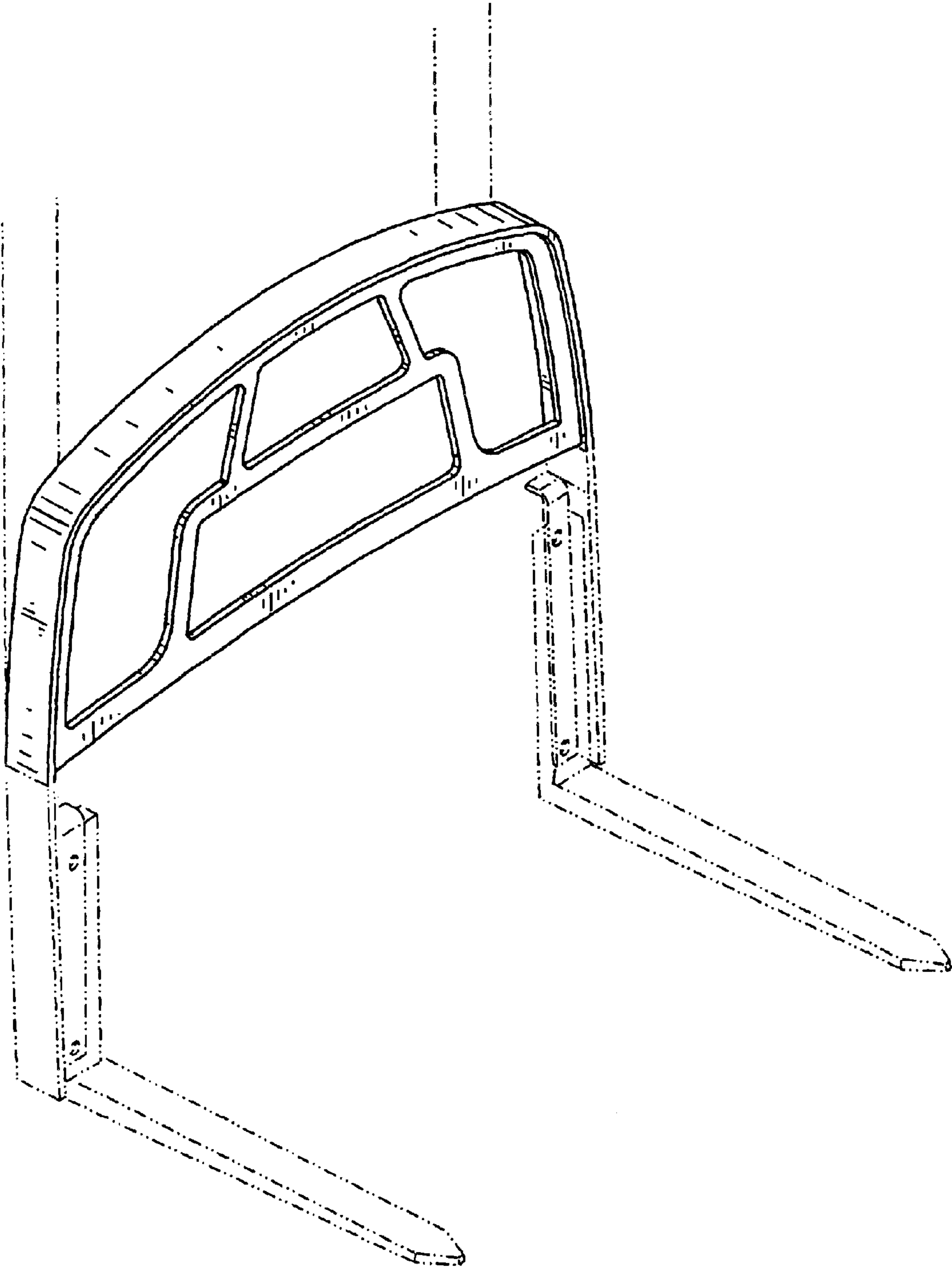

FIG. 11

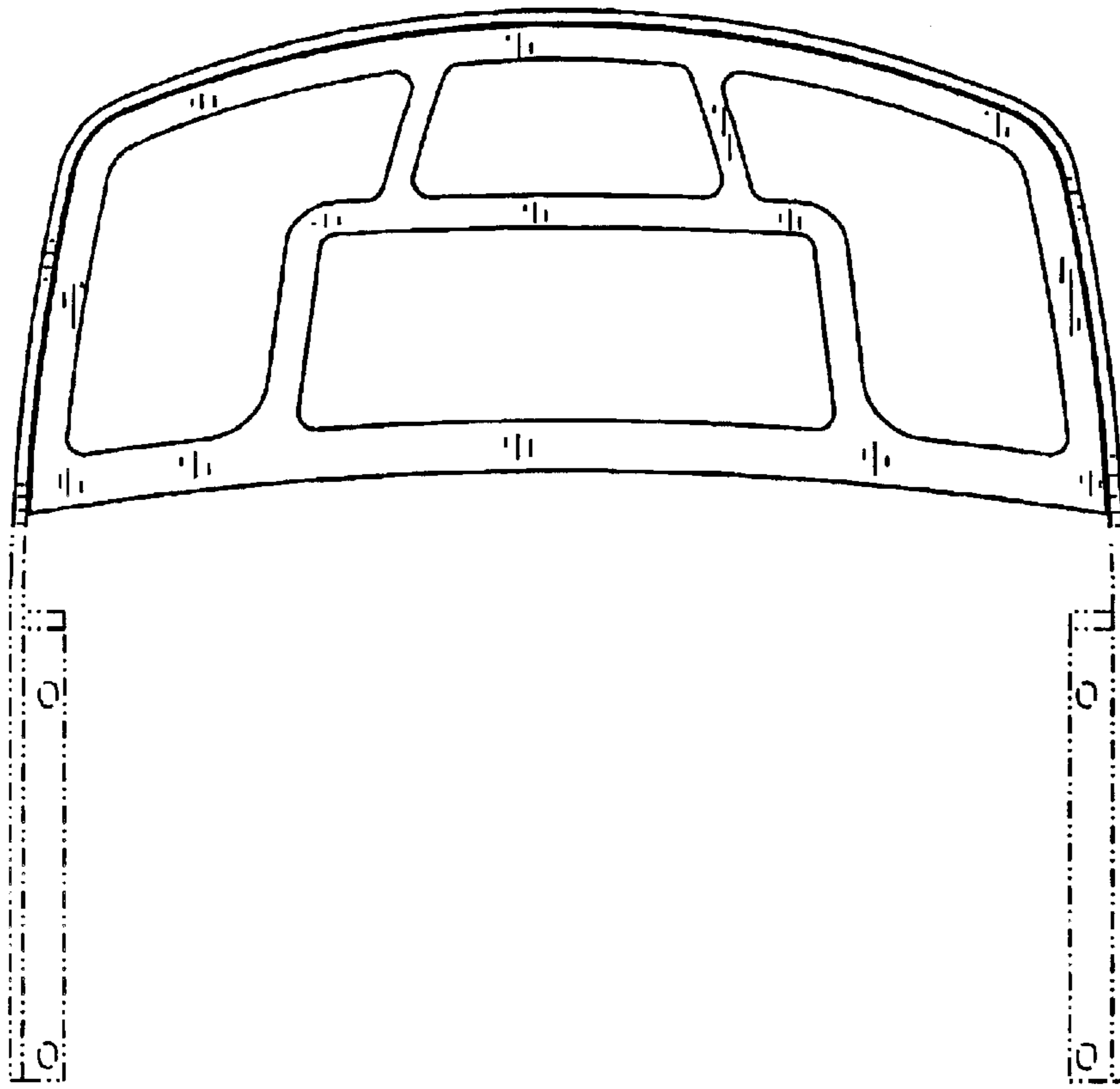

FIG. 12

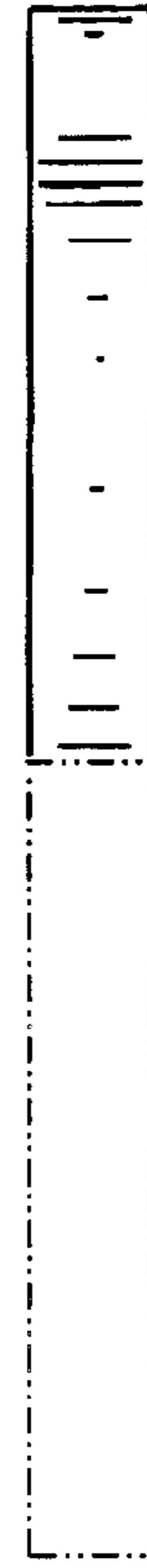

FIG. 13



FIG. 14



FIG. 15