

US00D499742S

(12) **United States Design Patent**
Brinton

(10) **Patent No.: US D499,742 S**

(45) **Date of Patent: ** Dec. 14, 2004**

(54) **PORTION OF A MOTORCYCLE CYLINDER HEAD**

(76) **Inventor: Keith A. Brinton**, 4375 E. Sahara Ave., Suite 29, Las Vegas, NV (US) 89104

(**) **Term: 14 Years**

(21) **Appl. No.: 29/189,985**

(22) **Filed: Sep. 12, 2003**

Related U.S. Application Data

(63) Continuation of application No. 10/049,244, filed as application No. PCT/US00/20535 on Jul. 27, 2000, now Pat. No. 6,626,134, which is a continuation of application No. 09/361,325, filed on Jul. 27, 1999, now abandoned.

(51) **LOC (7) Cl. 15-01**

(52) **U.S. Cl. D15/5**

(58) **Field of Search** D15/1-5; D12/107, D12/110, 114; 123/41.56, 41.69, 54.1, 196 AB, 197.3; 165/181, 179

(56) **References Cited**

U.S. PATENT DOCUMENTS

- 2,398,216 A 4/1946 Francisco, Jr.
- 2,771,277 A 11/1956 Cross
- 3,782,342 A 1/1974 Schier
- 4,007,773 A 2/1977 McCormick
- 4,170,260 A 10/1979 Rudd et al.
- 4,589,512 A 5/1986 Yamaguchi
- 4,928,651 A * 5/1990 Kronich 123/196 AB
- 5,240,070 A 8/1993 Ryan
- 5,259,448 A 11/1993 Masukawa et al.
- 5,421,292 A 6/1995 Hoffman et al.

- 5,996,686 A 12/1999 Thors et al.
- 6,098,420 A 8/2000 Furukawa et al.
- D432,546 S * 10/2000 Savage et al. D15/5
- 6,173,762 B1 1/2001 Ishida et al.
- D463,451 S * 9/2002 Wangen D15/5
- D463,801 S * 10/2002 Kinsey et al. D15/5
- D466,133 S * 11/2002 Kinsey et al. D15/5
- D467,940 S * 12/2002 Kinsey et al. D15/5
- 6,626,134 B1 9/2003 Brinton

OTHER PUBLICATIONS

Printed copy of yourMachinist website, URL <http://www.yourmachinist.com/>, printed Feb. 20, 2003.

International Search Report dated Oct. 3, 2000.

* cited by examiner

Primary Examiner—Melody N. Brown

(74) *Attorney, Agent, or Firm*—TraskBritt

(57) **CLAIM**

The ornamental design for a portion of a motorcycle cylinder head, as shown and described.

DESCRIPTION

FIG. 1 is a perspective view of a portion of a motorcycle cylinder head showing my new design; and, FIG. 2 is a side view of the motorcycle cylinder head shown in FIG. 1.

The uneven broken line, immediately adjacent to the shaded areas, represents the bounds of the claimed design. All other uneven broken lines represent the remaining portion of the motorcycle cylinder head. The uneven broken line representations in FIGS. 1-2 are for illustrative purposes only and form no part of the claimed design.

1 Claim, 2 Drawing Sheets

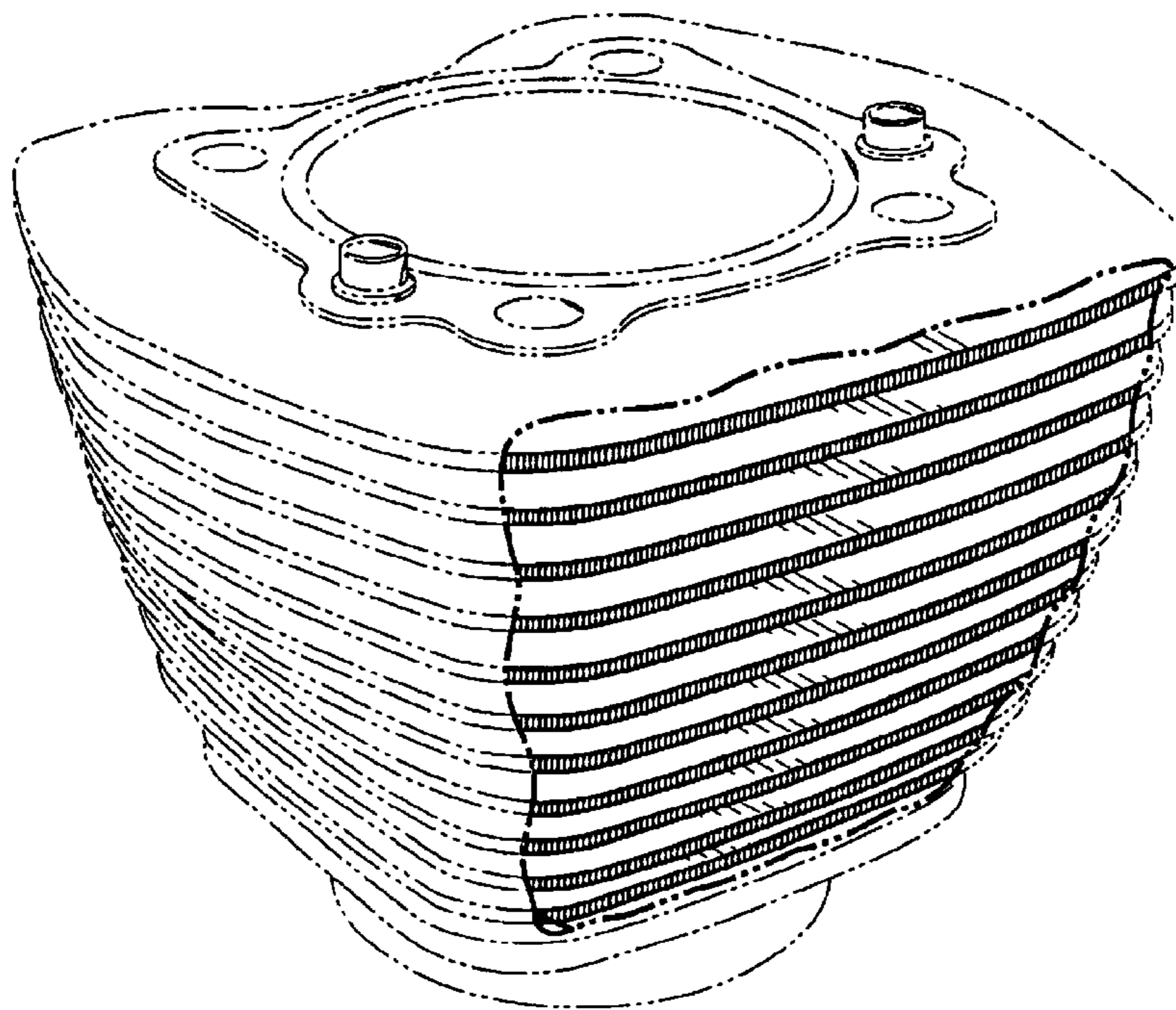

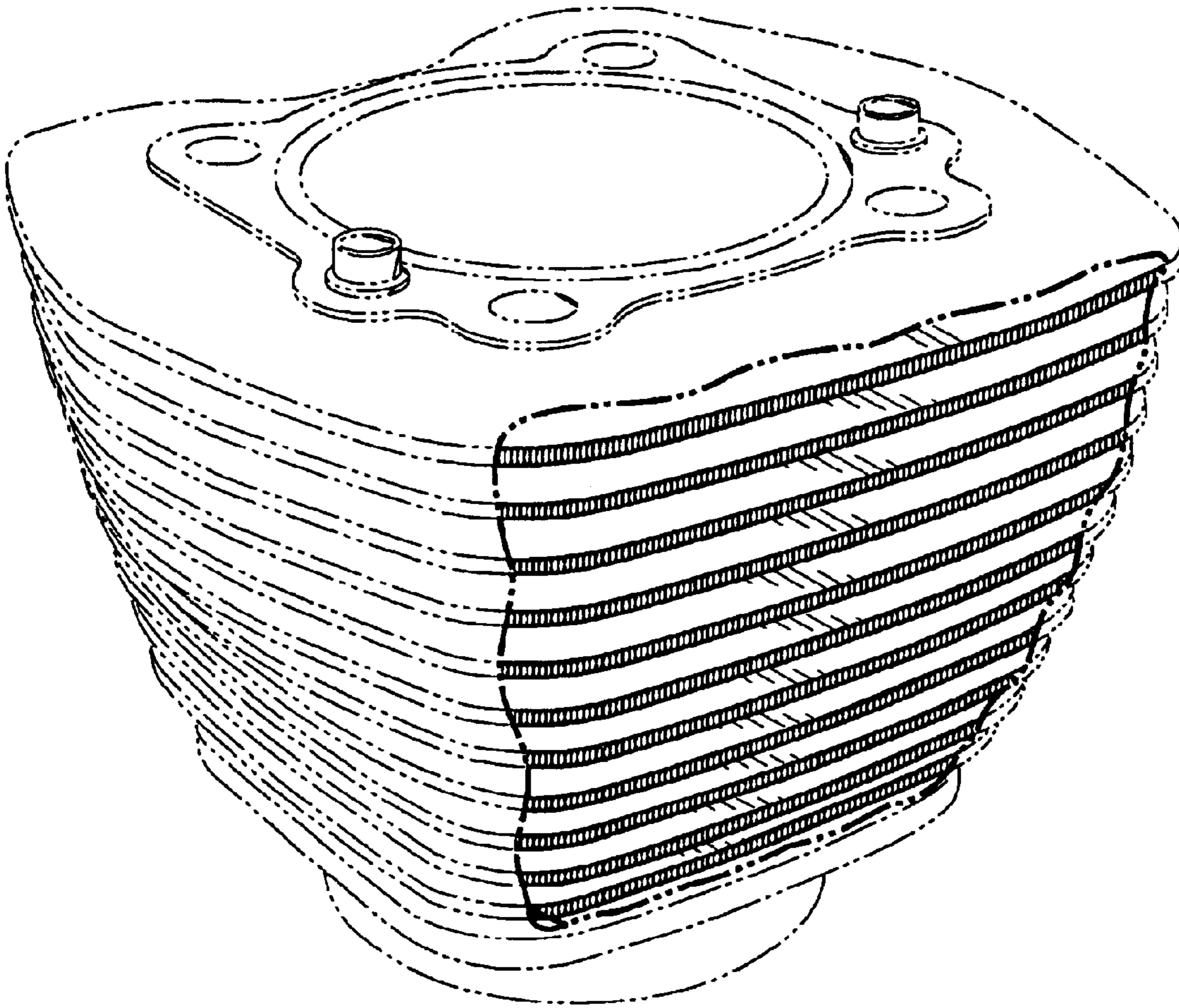

Fig. 1

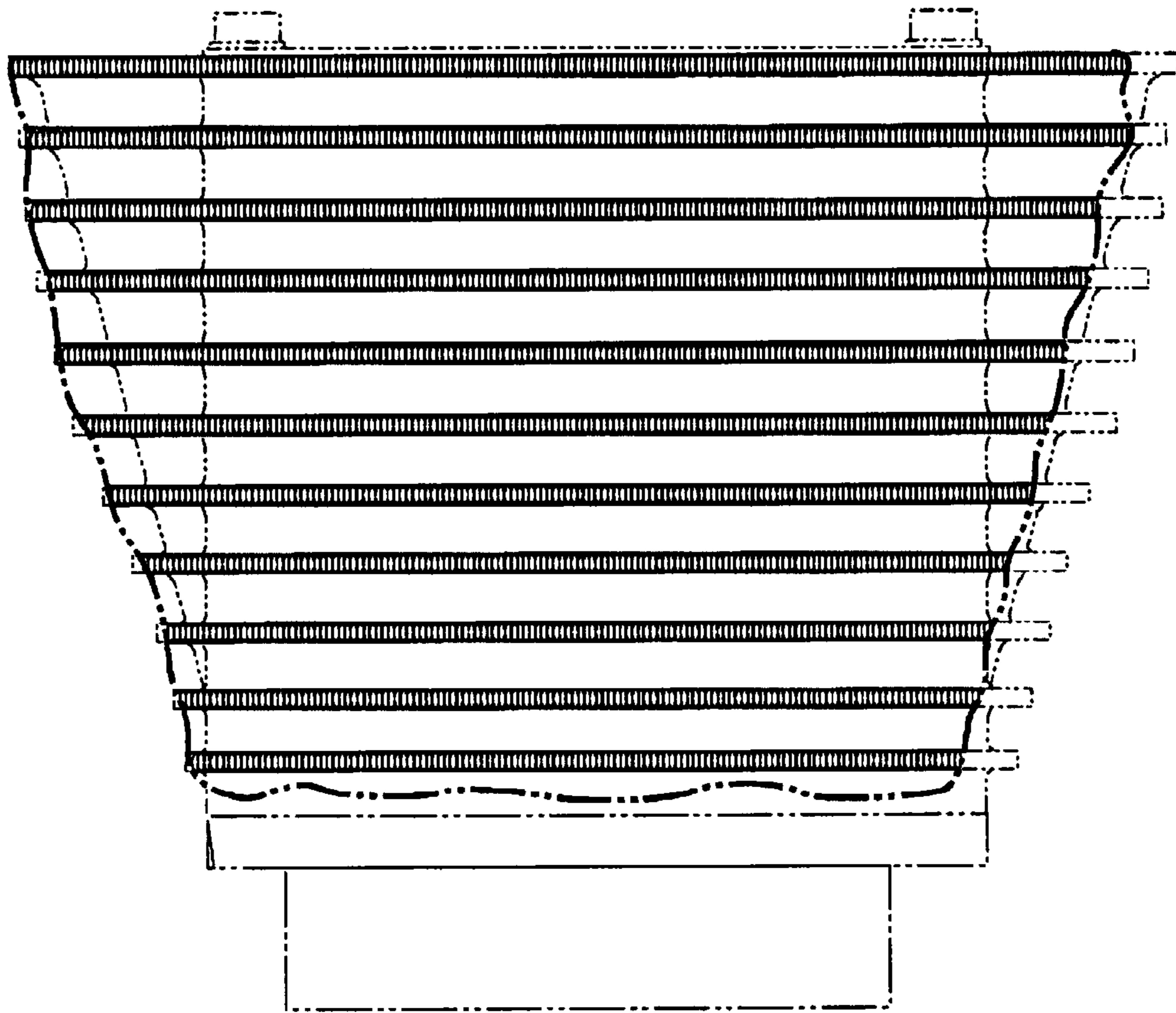

Fig. 2