

US00D499689S

(12) **United States Design Patent**
Han

(10) **Patent No.:** **US D499,689 S**

(45) **Date of Patent:** **** Dec. 14, 2004**

(54) **TRIPLE ENGINE JET FIGHTER SINGLE SEATER**

D479,501 S * 9/2003 Nelson D12/319
D485,577 S * 1/2004 Lord et al. D19/66

(76) **Inventor:** **Charlie K. Han**, P.O. Box 2131, Union City, CA (US) 94587

* cited by examiner

Primary Examiner—Marcus A. Jackson

(**) **Term:** **14 Years**

(57) **CLAIM**

(21) **Appl. No.:** **29/200,748**

The ornamental design for a triple engine jet fighter single seater, as shown and described.

(22) **Filed:** **Mar. 4, 2004**

DESCRIPTION

(51) **LOC (7) Cl.** **12-99**

(52) **U.S. Cl.** **D12/319**

(58) **Field of Search** D12/319-345;
244/45 A, 45 R, 13, 15, 91, 198, 211, 218

FIG. 1 is a front elevational view of a triple engine jet fighter single seater;
FIG. 2 is a side elevational view thereof, with the opposite side being a mirror image;
FIG. 3 is a top plan view thereof; and,
FIG. 4 is a perspective view thereof.

(56) **References Cited**

U.S. PATENT DOCUMENTS

D467,533 S * 12/2002 Han D12/319

1 Claim, 4 Drawing Sheets

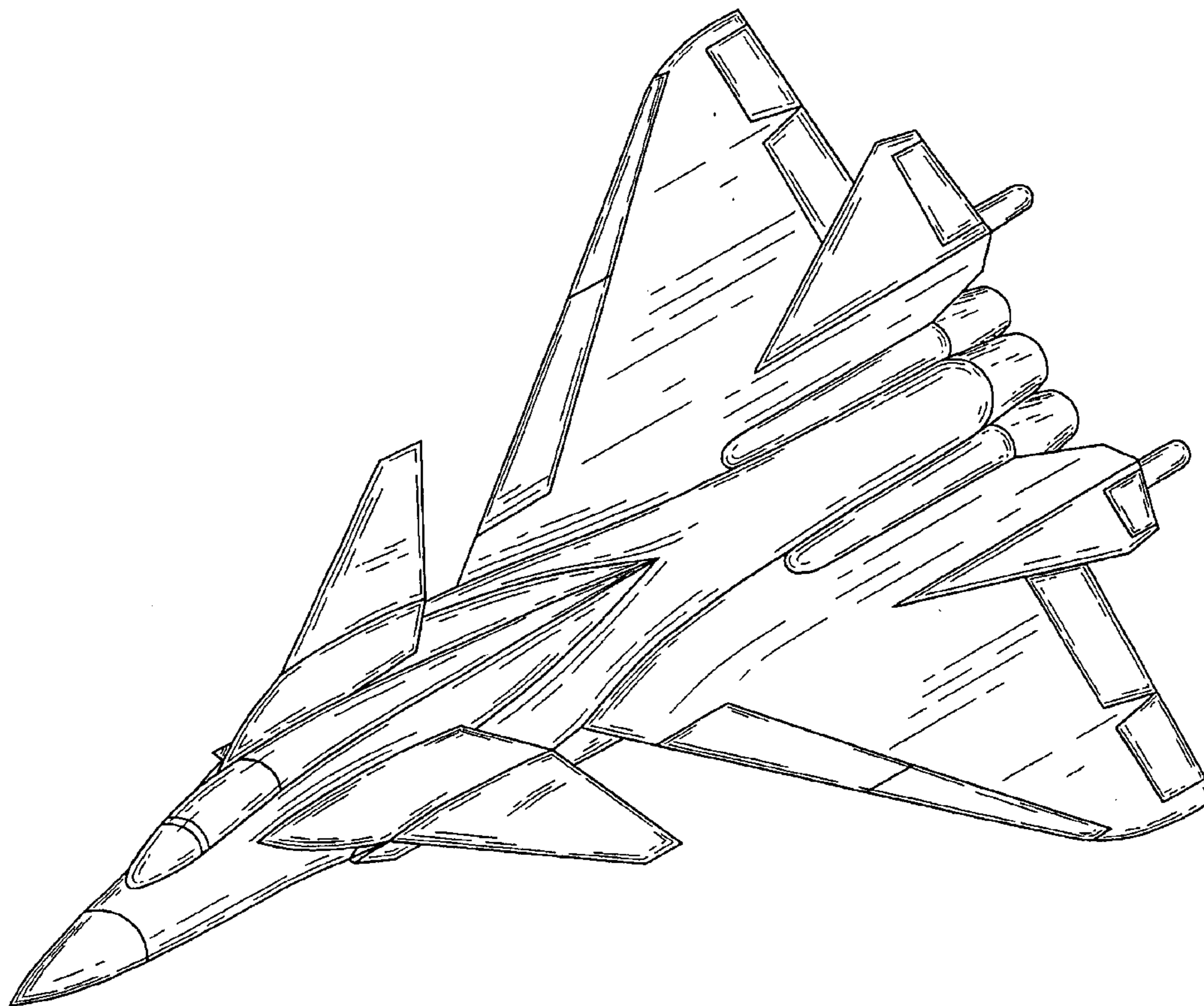

PERSPECTIVE VIEW

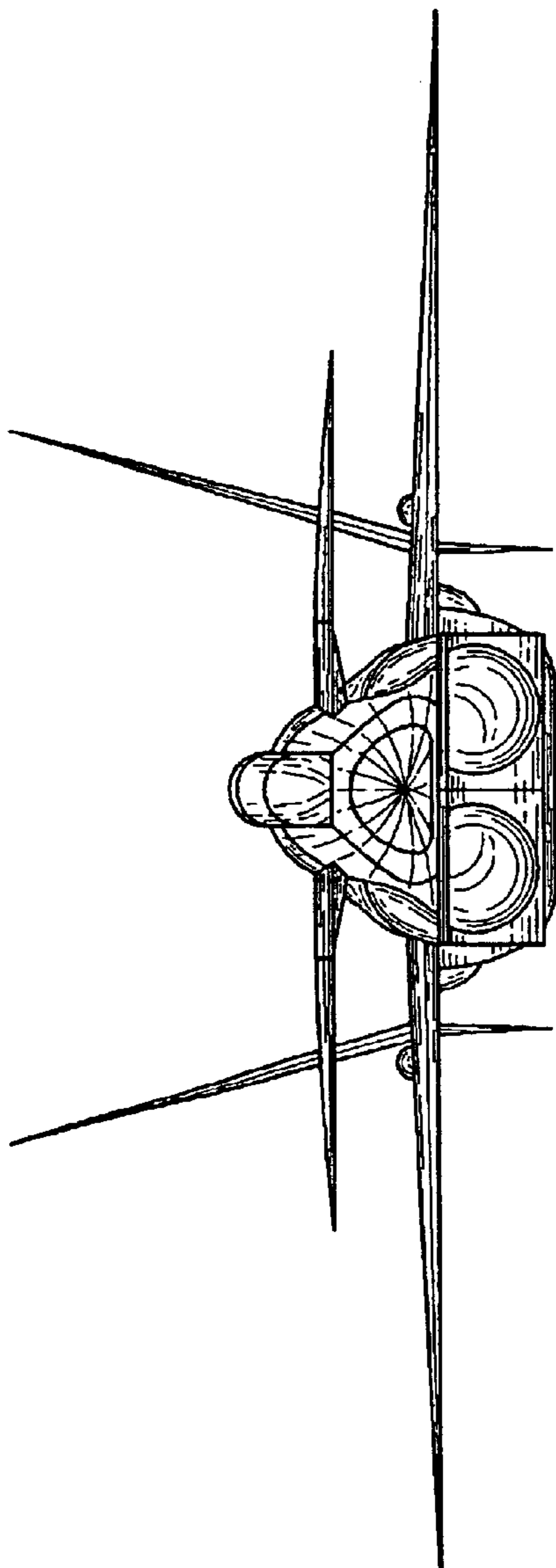

Fig. 1

FRONT VIEW

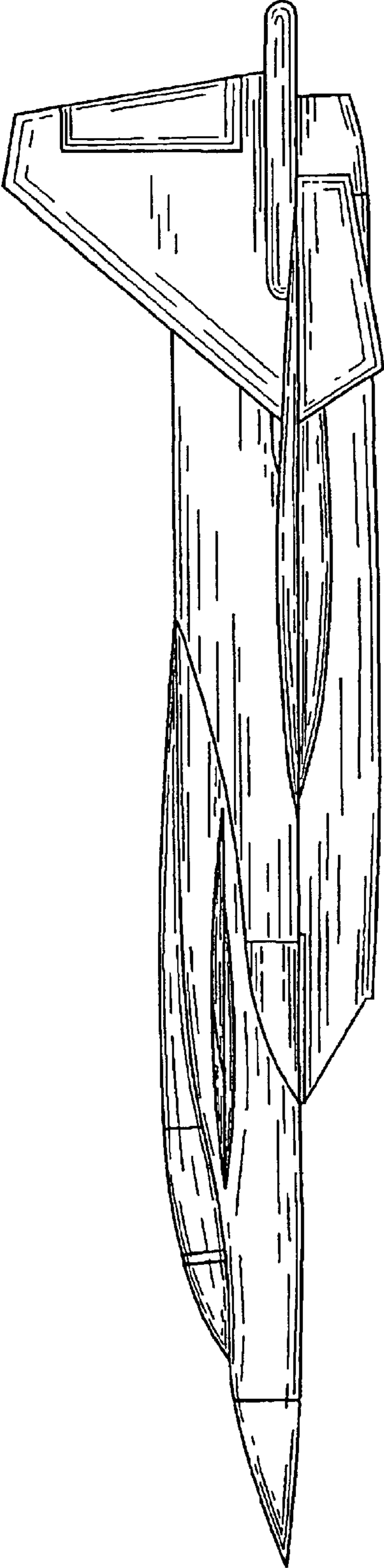

Fig. 2

SIDE VIEW

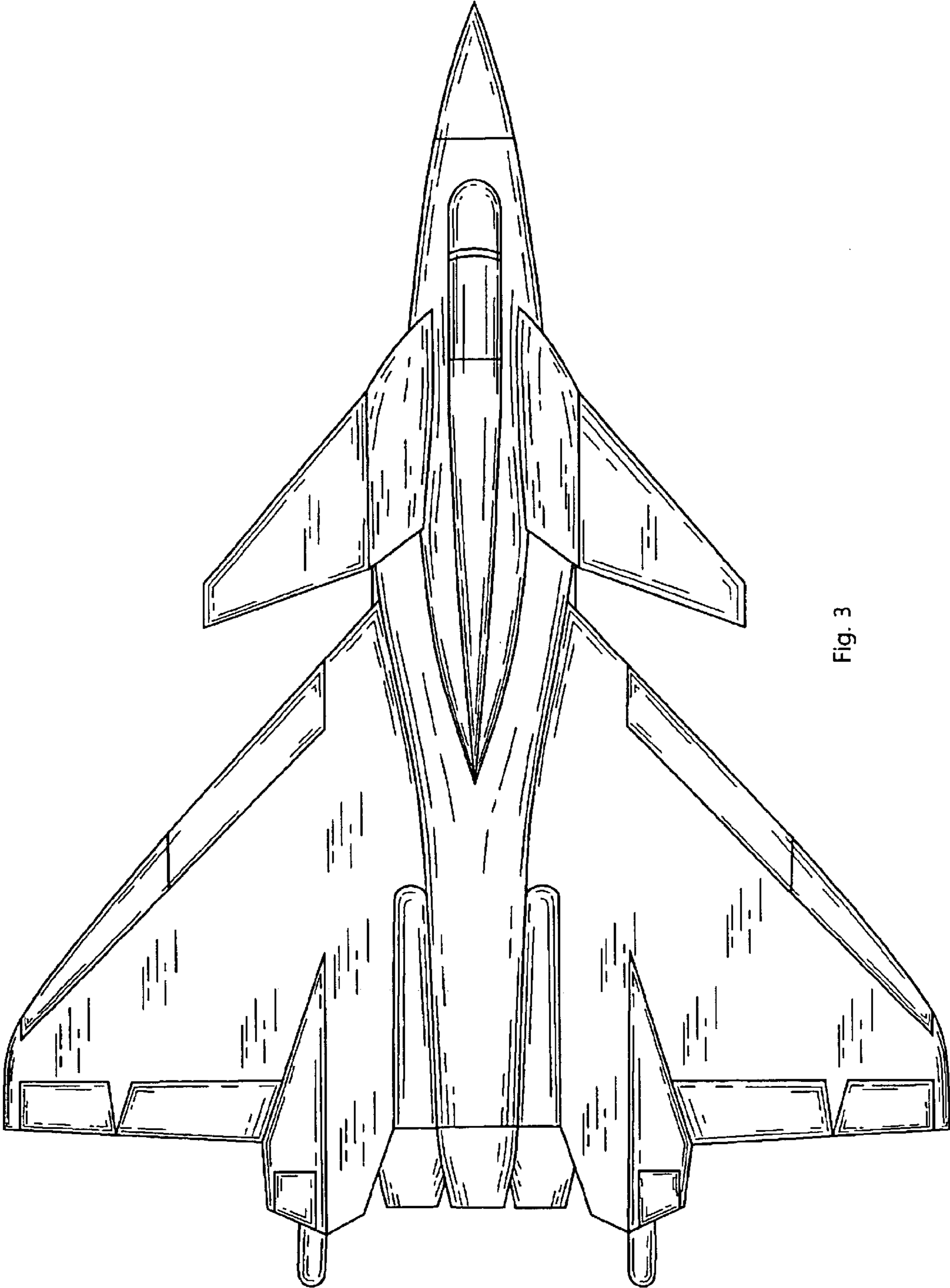

Fig. 3

TOP VIEW

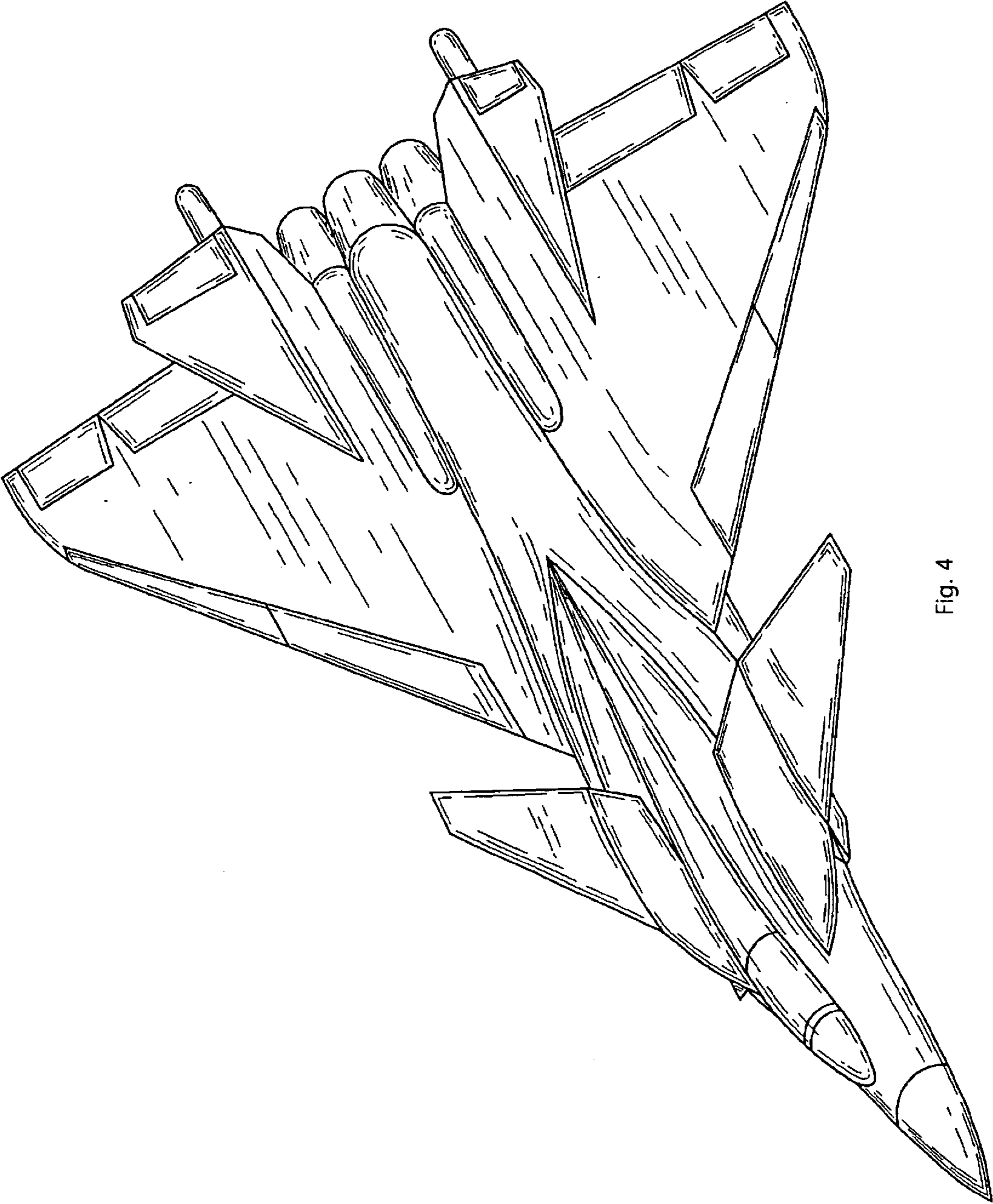

Fig. 4

PERSPECTIVE VIEW