

US00D499672S

(12) **United States Design Patent**  
**Thompson**

(10) **Patent No.:** **US D499,672 S**

(45) **Date of Patent:** **\*\* Dec. 14, 2004**

(54) **MULTIPLE WHEEL RACK**

5,833,074 A 11/1998 Phillips  
6,182,836 B1 \* 2/2001 Gutierrez ..... 211/22  
6,298,999 B1 10/2001 Bellman

(75) **Inventor:** **Stephen Thompson**, Burton upon Trent (GB)

\* cited by examiner

(73) **Assignee:** **Brumby Corporation Limited** (GB)

*Primary Examiner*—Alan P. Douglas

(\*\*) **Term:** **14 Years**

*Assistant Examiner*—Linda Brooks

(74) *Attorney, Agent, or Firm*—Kenyon & Kenyon

(21) **Appl. No.:** **29/174,729**

(57) **CLAIM**

(22) **Filed:** **Jan. 23, 2003**

The ornamental design for a multiple wheel rack, as shown and described.

(30) **Foreign Application Priority Data**

Jul. 26, 2002 (GB) ..... 3005652

**DESCRIPTION**

(51) **LOC (7) Cl.** ..... **12-11**

FIG. 1 is a front view of a multiple wheel rack illustrating my new design;

(52) **U.S. Cl.** ..... **D12/115**

FIG. 2 is a perspective view thereof;

(58) **Field of Search** ..... D12/115; 211/17-22

FIG. 3 is a rear view thereof;

FIG. 4 is a left view thereof;

FIG. 5 is a right view, thereof;

FIG. 6 is a top view, thereof; and,

FIG. 7 is a bottom view thereof.

The broken lines shown are for illustrative purposes only and form no part of the claimed design.

(56) **References Cited**

**U.S. PATENT DOCUMENTS**

4,465,196 A 8/1984 Erb  
5,292,009 A 3/1994 Smith  
5,370,285 A 12/1994 Steelman  
D355,632 S 2/1995 Padgett  
5,482,194 A 1/1996 Hallock, III

**1 Claim, 7 Drawing Sheets**

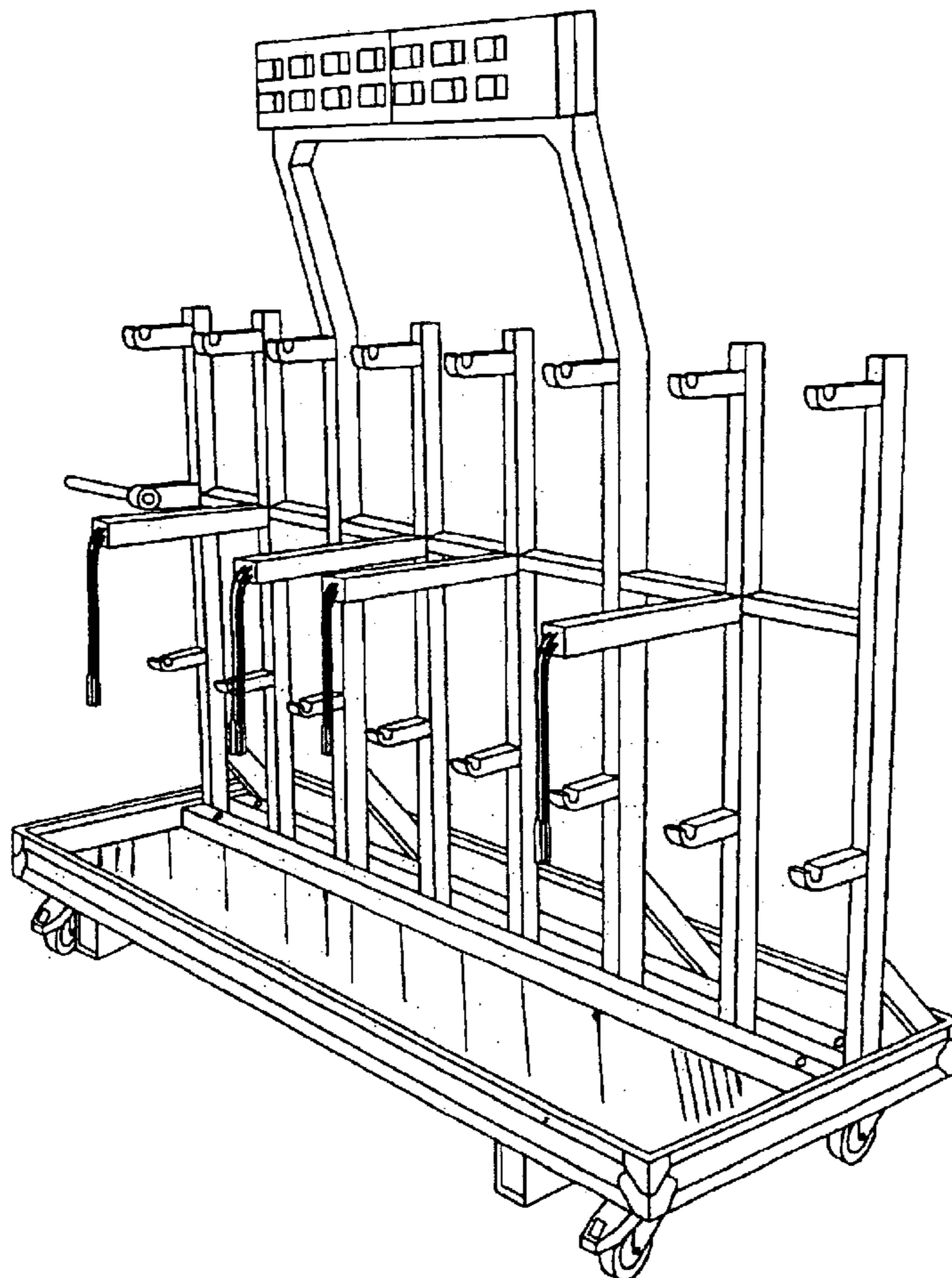

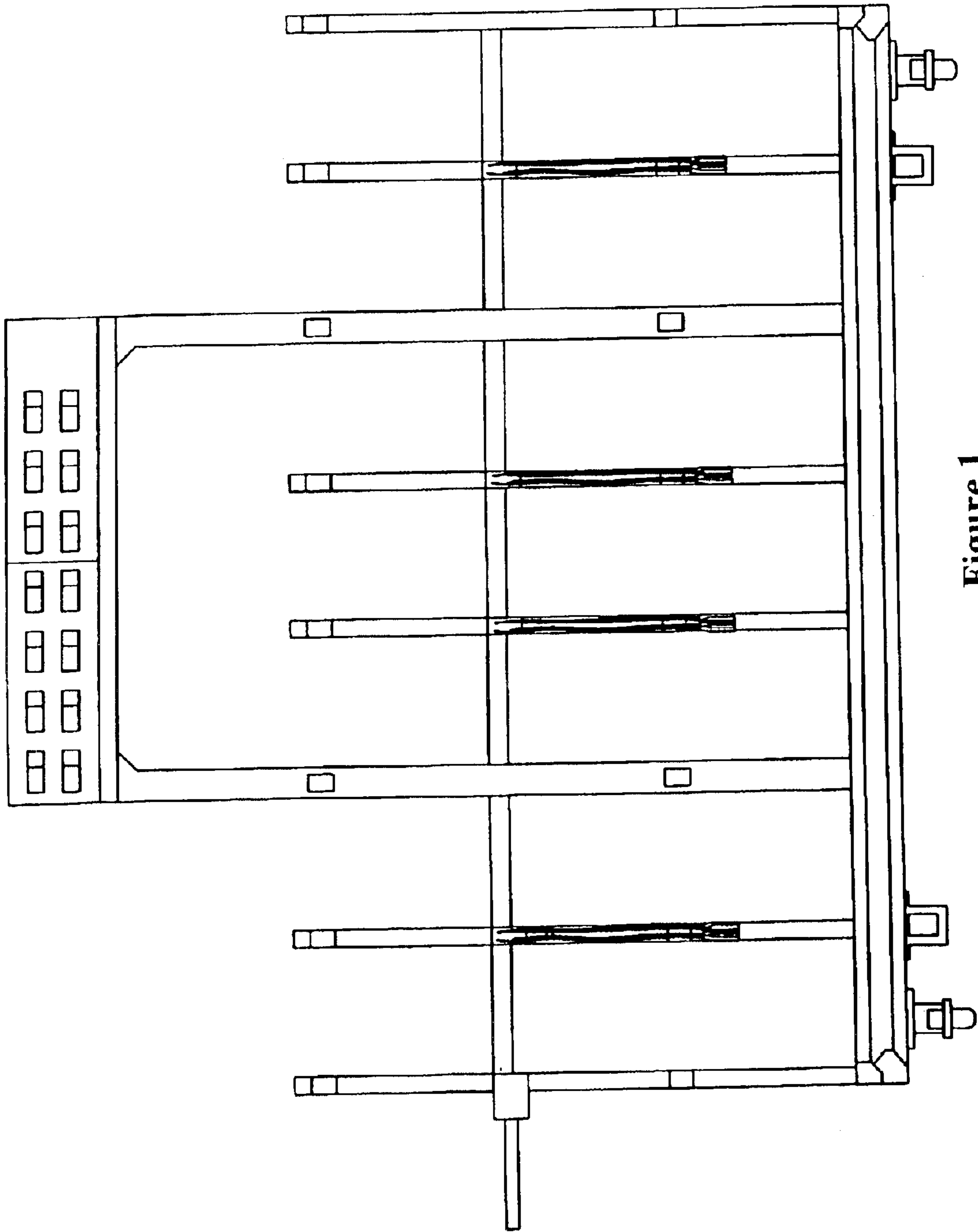

Figure 1

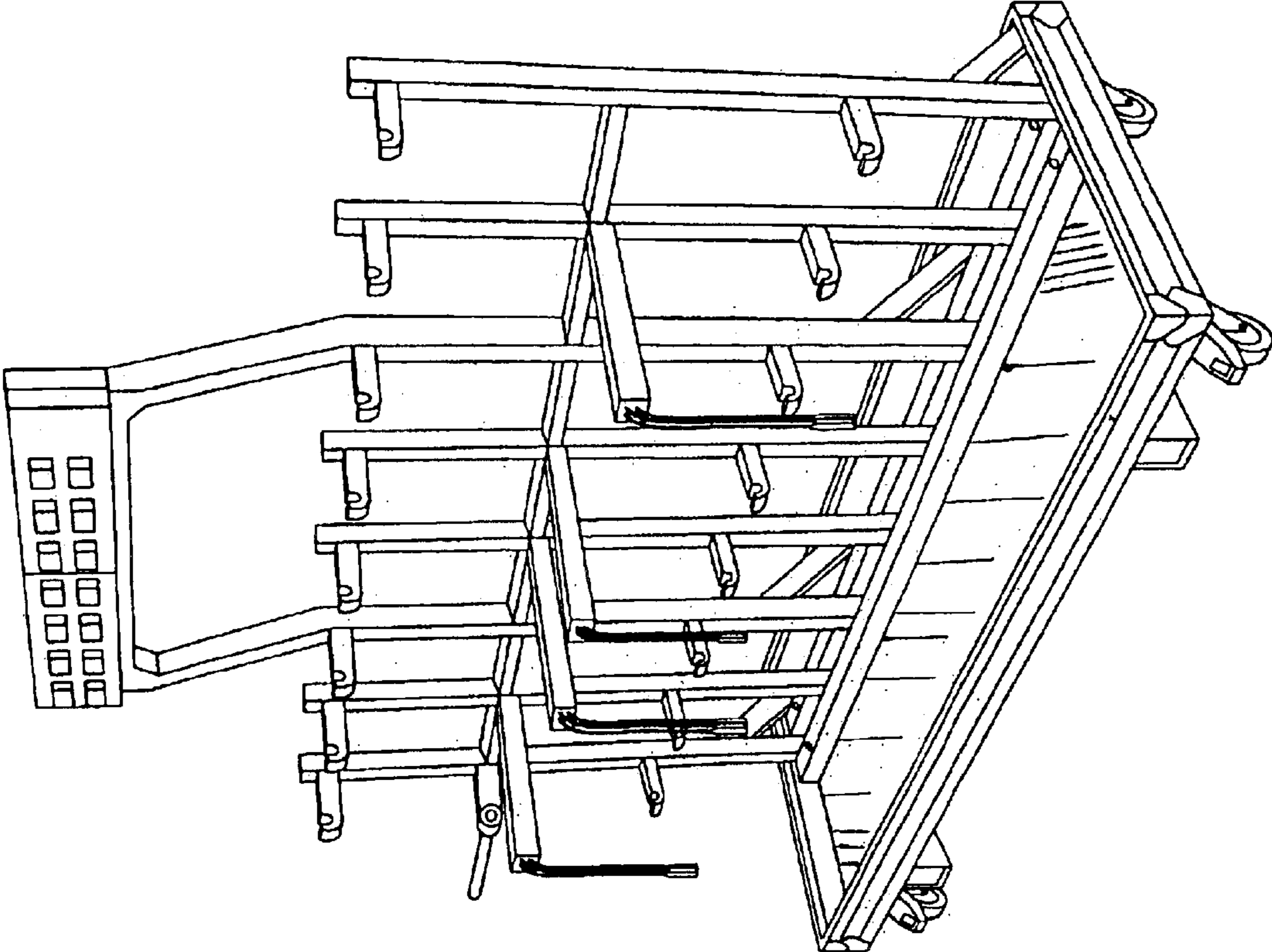

Figure 2

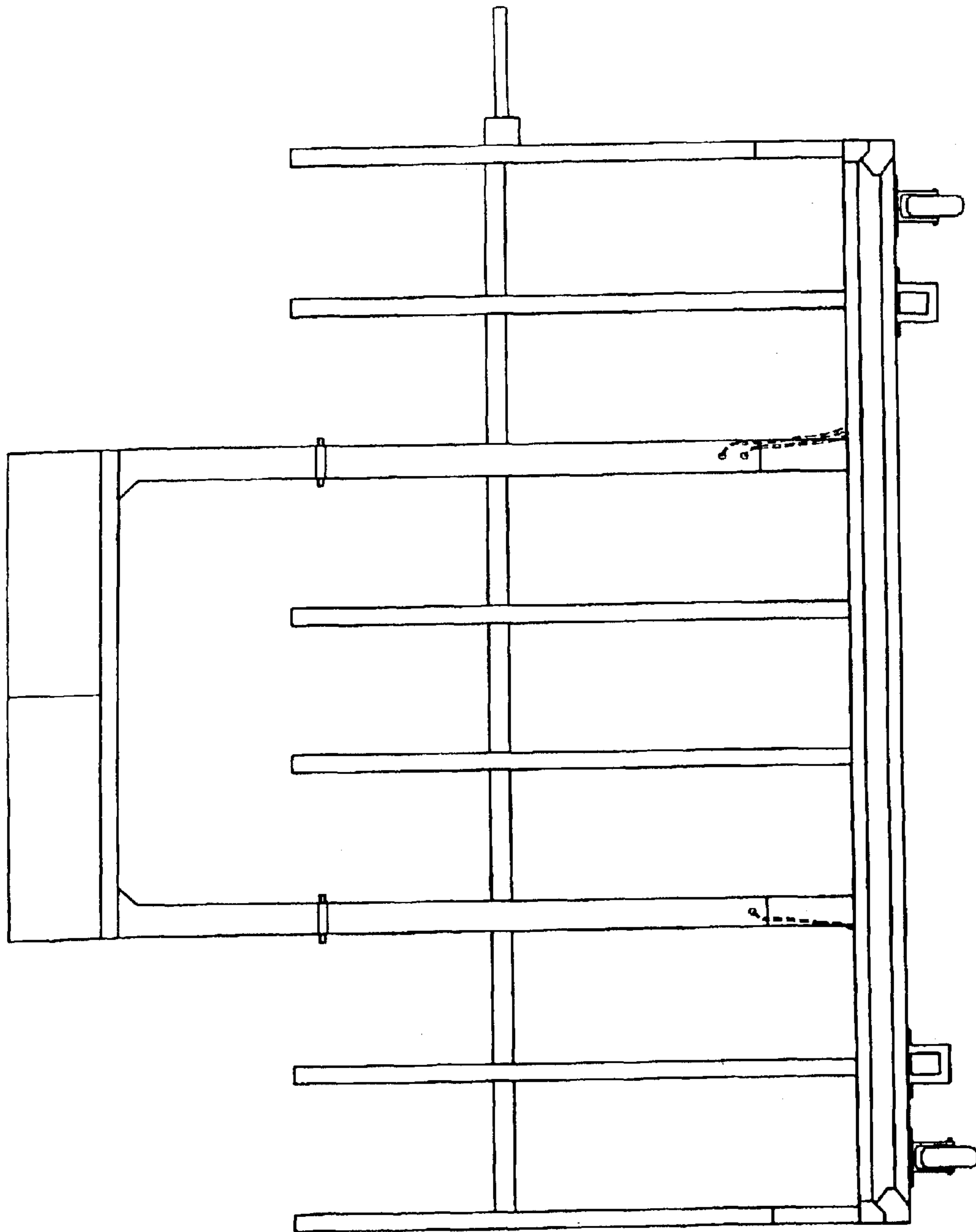

Figure 3

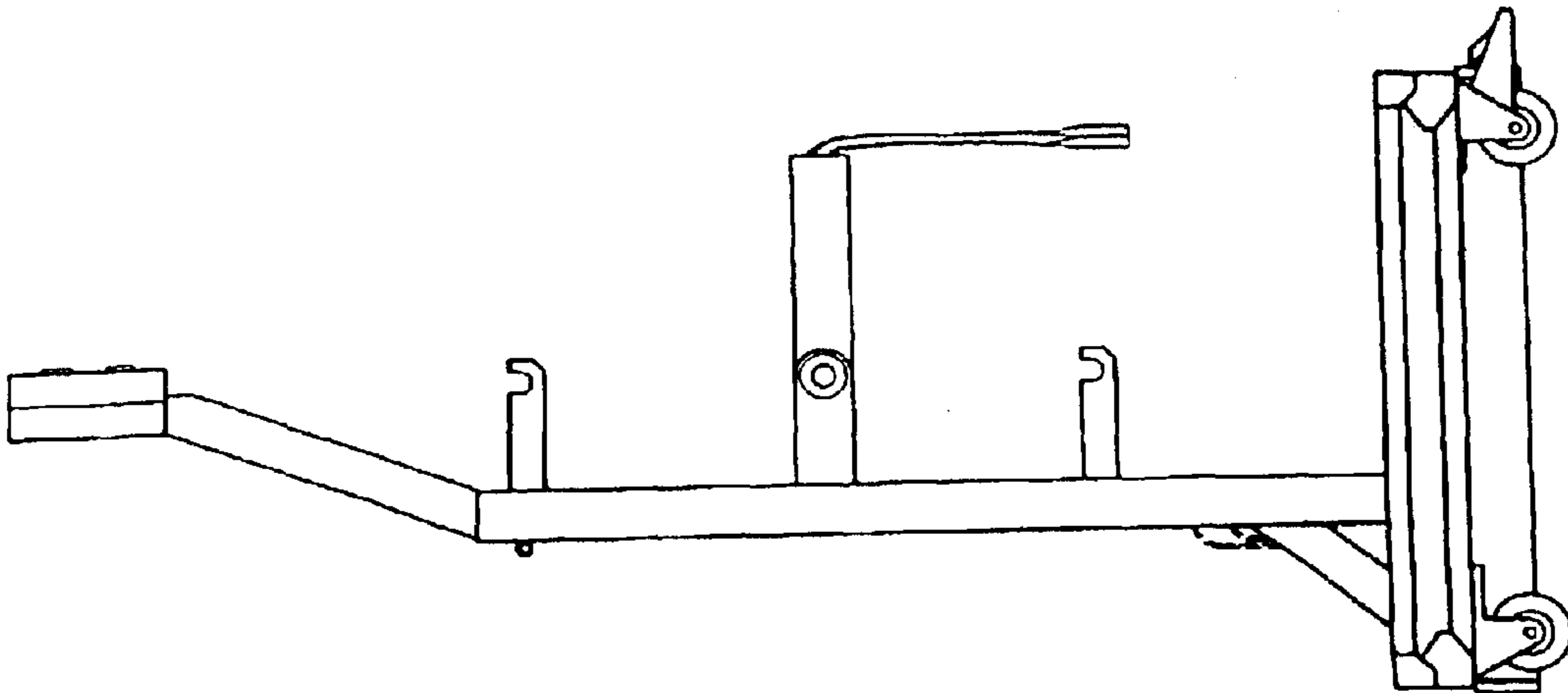

Figure 4

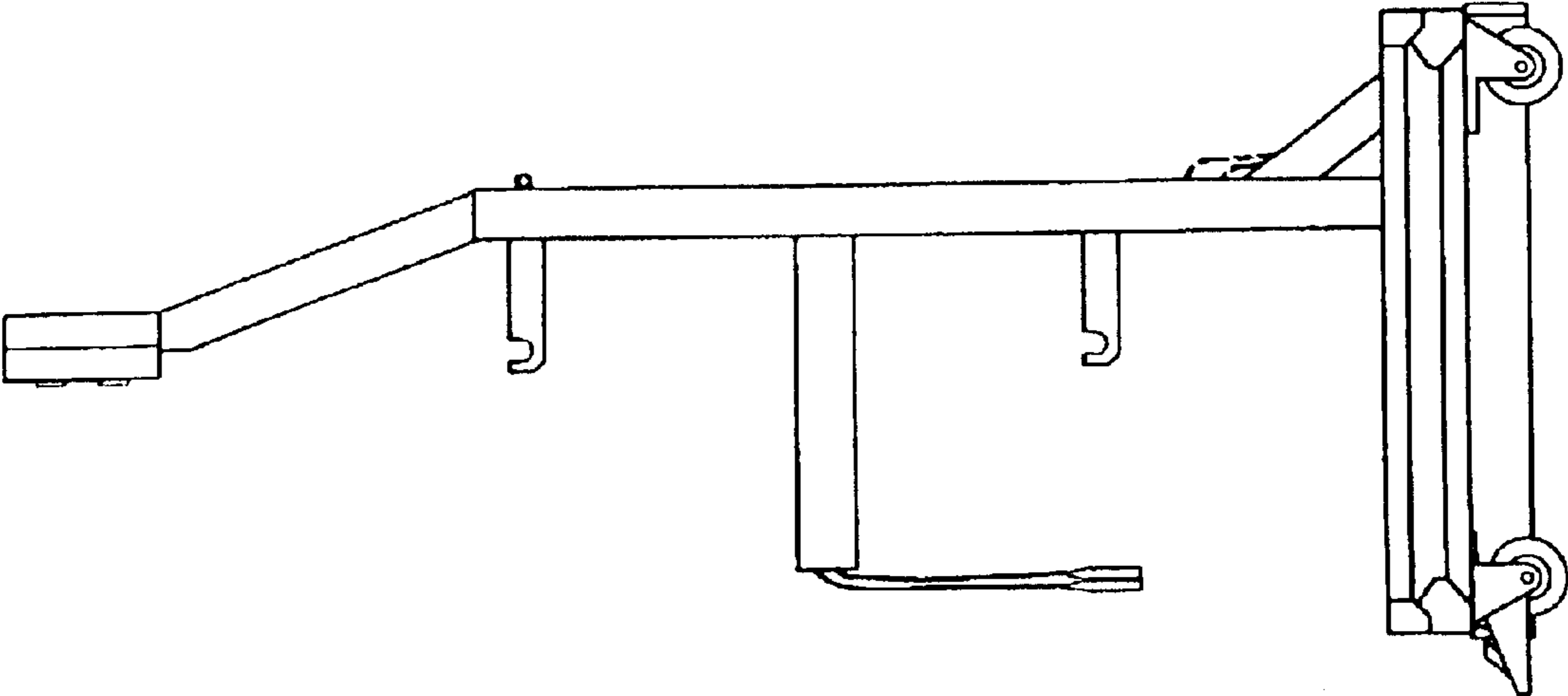

Figure 5

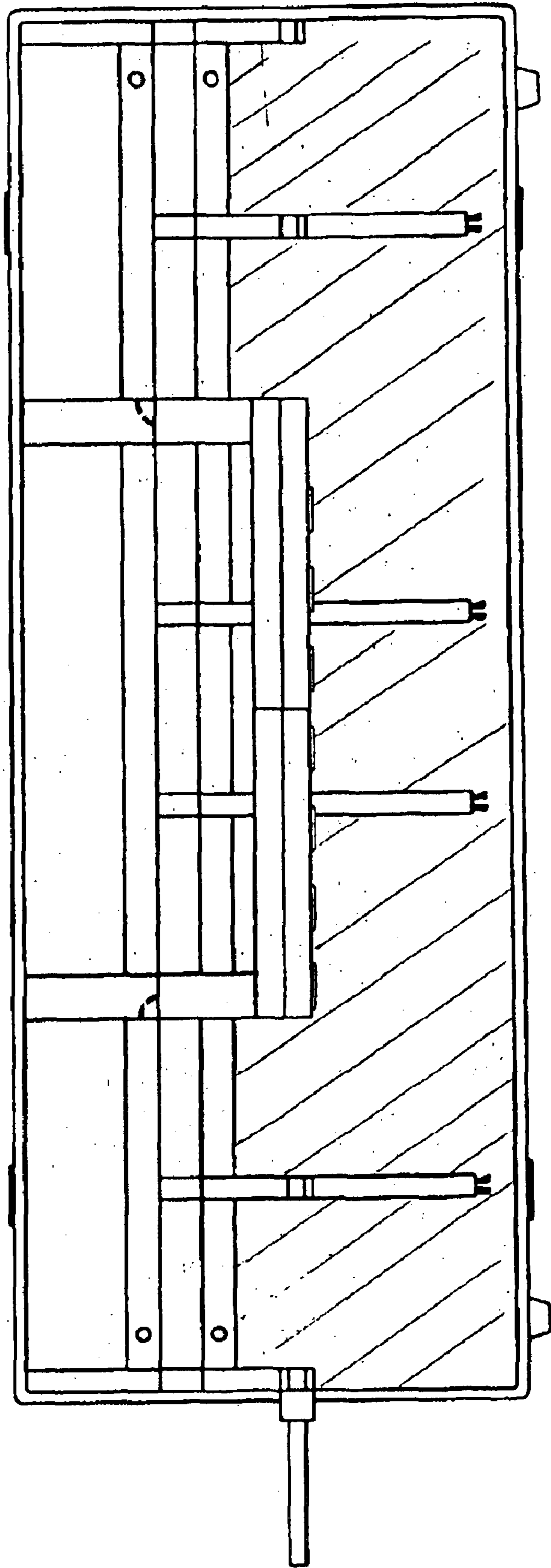

Figure 6



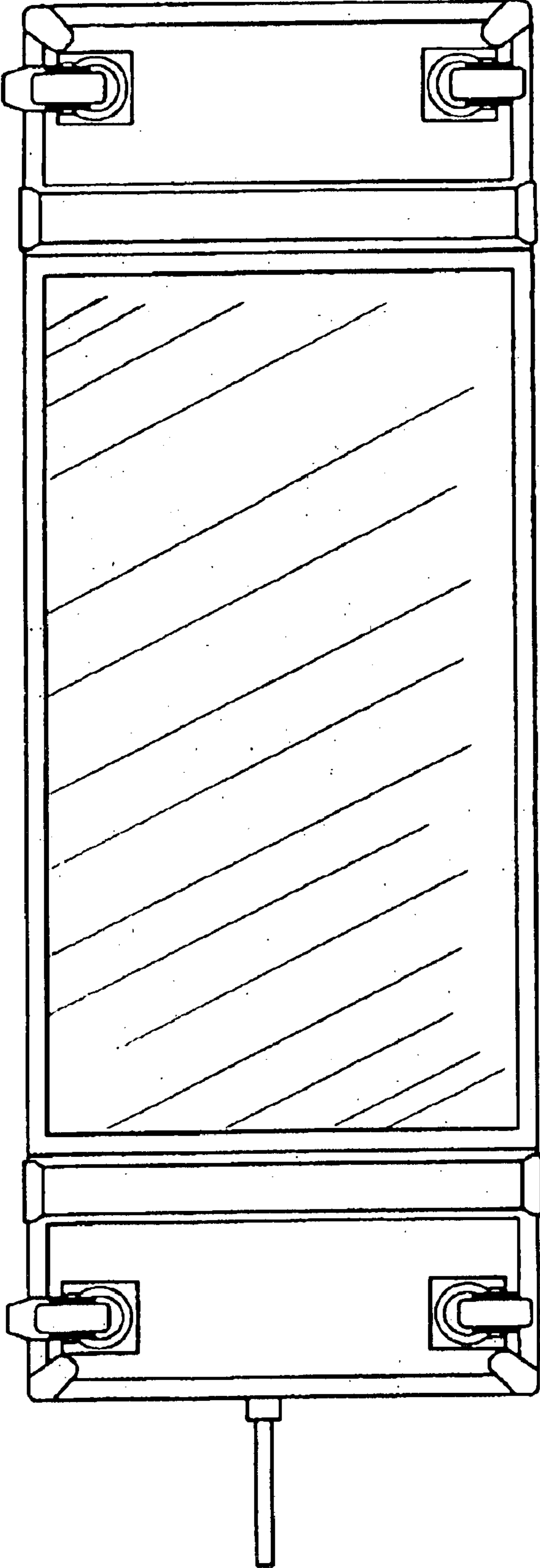

Figure 7