

US00D499523S

(12) **United States Design Patent**  
Werner et al.

(10) **Patent No.:** **US D499,523 S**  
(45) **Date of Patent:** **\*\* Dec. 7, 2004**

(54) **CONTROL HANDLE FOR A MATERIAL HANDLING VEHICLE**

D335,741 S \* 5/1993 McCormick et al. .... D34/35  
D336,713 S \* 6/1993 Avitan et al. .... D34/35  
D405,581 S \* 2/1999 Henshaw et al. .... D34/35

(75) Inventors: **Kurt R. Werner**, Auburn, NY (US);  
**Gregory W. Smiley**, Greene, NY (US);  
**Benjamin D. Johnson**, Binghamton, NY (US)

\* cited by examiner

*Primary Examiner*—Holly Baynham  
(74) *Attorney, Agent, or Firm*—Quarles & Brady LLP

(73) Assignee: **The Raymond Corporation**, Greene, NY (US)

(57) **CLAIM**

The ornamental design for a control handle for a material handling vehicle, as shown and described.

(\*\*) Term: **14 Years**

**DESCRIPTION**

(21) Appl. No.: **29/189,671**

In a preferred embodiment, the nature of this product is as a handle useful for controlling a material handling vehicle. FIG. 1 is a top, left, front perspective view of a control handle for a material handling vehicle embodying our new design; FIG. 2 is a front elevational view thereof; FIG. 3 is a top plan view thereof; FIG. 4 is a rear elevational view thereof; and, FIG. 5 is a left side elevational view thereof. The broken line representations of portions of a material handling vehicle and control handle in FIGS. 1–5, are for the purpose of illustration only, and form no part of the claimed design.

(22) Filed: **Sep. 9, 2003**

(51) **LOC (7) Cl.** ..... **12-05**

(52) **U.S. Cl.** ..... **D34/35**

(58) **Field of Search** ..... D34/28, 34–35;  
180/299, 315, 89, 12; 280/43.12; 187/222,  
224; 414/685, 294, 679; D12/174, 179;  
244/234

(56) **References Cited**

**U.S. PATENT DOCUMENTS**

D320,589 S \* 10/1991 Kelley et al. .... D12/179  
D331,559 S \* 12/1992 Kelley et al. .... D12/179

**1 Claim, 3 Drawing Sheets**

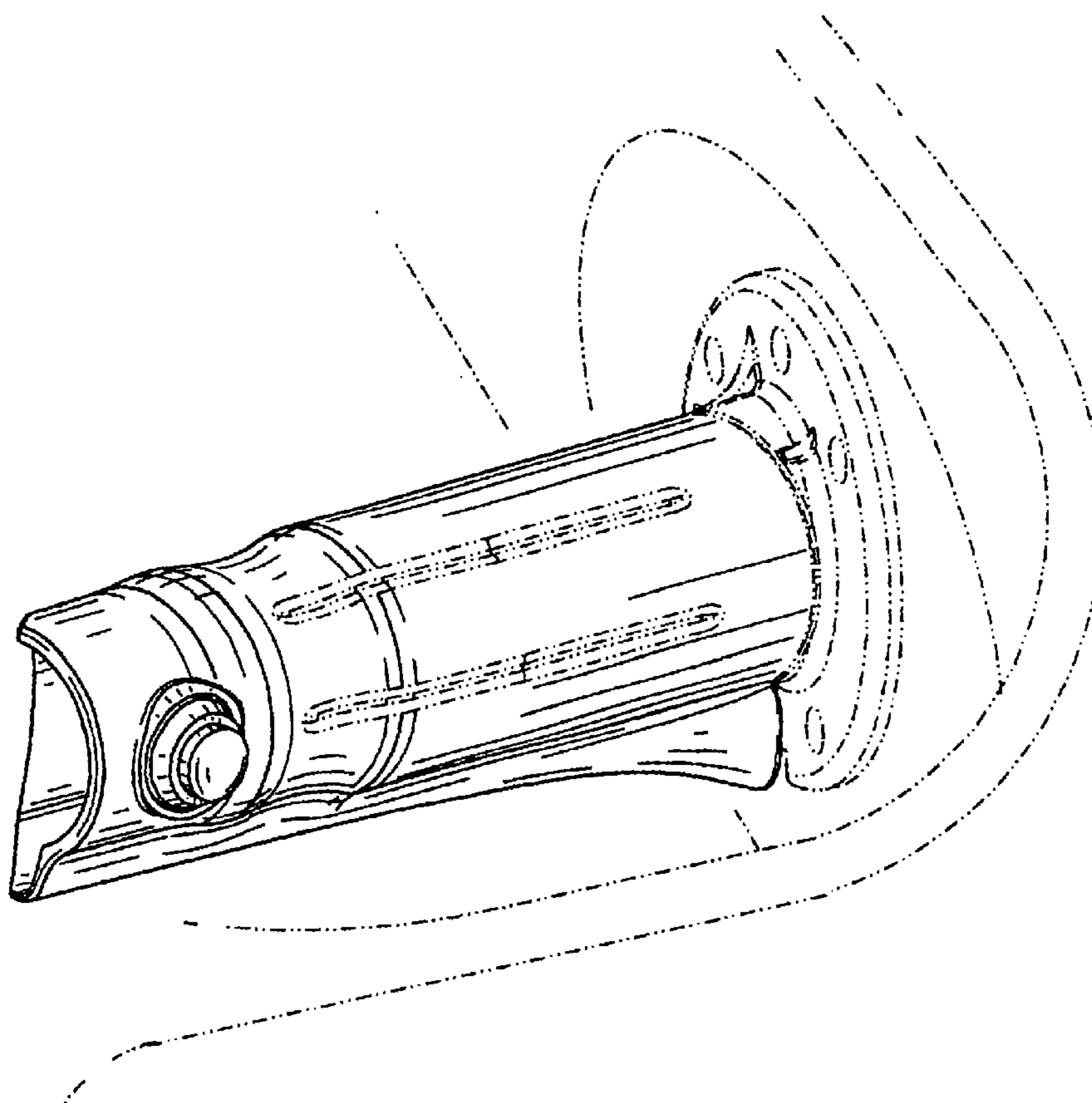

FIG. 1

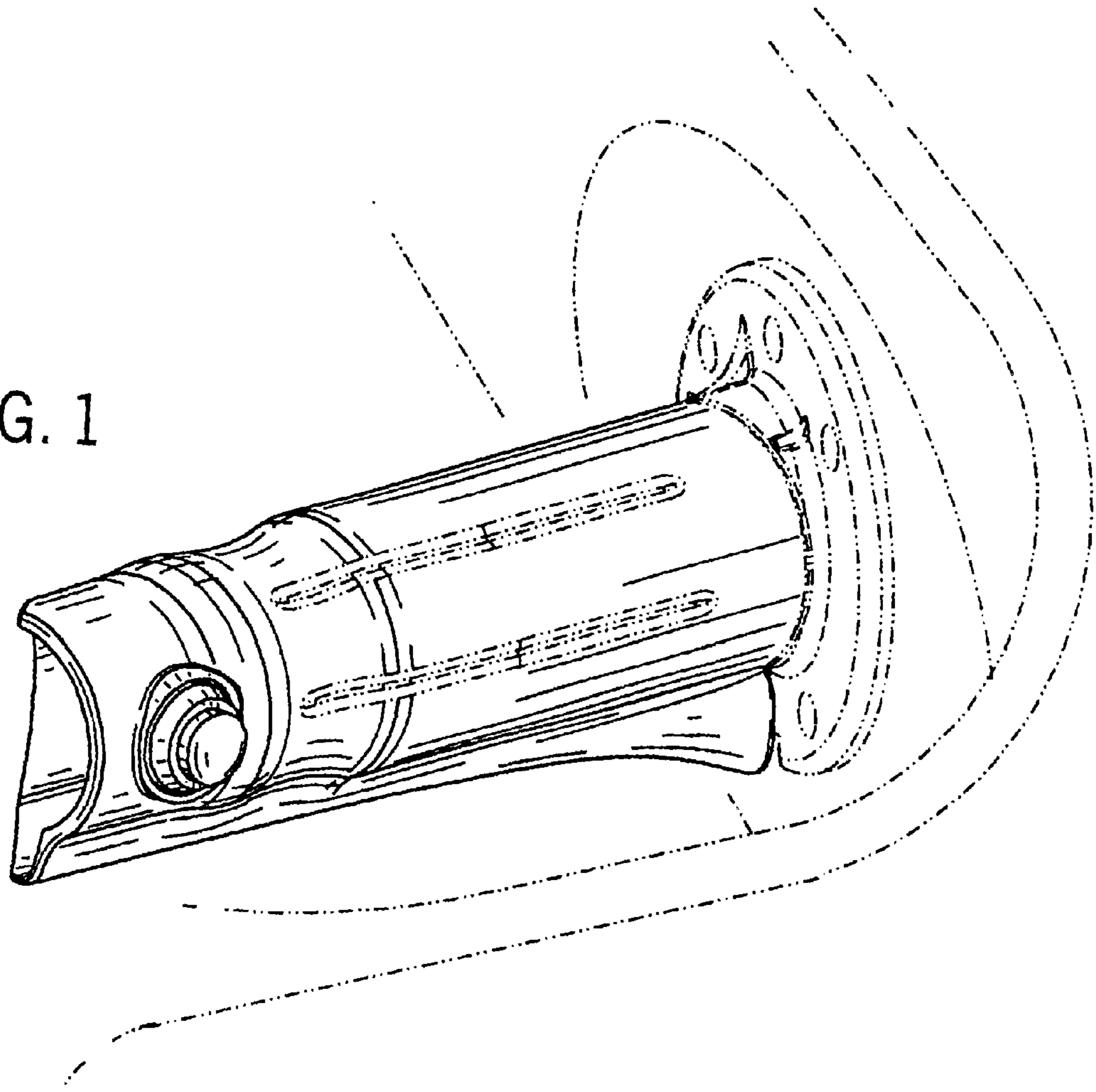

FIG. 2

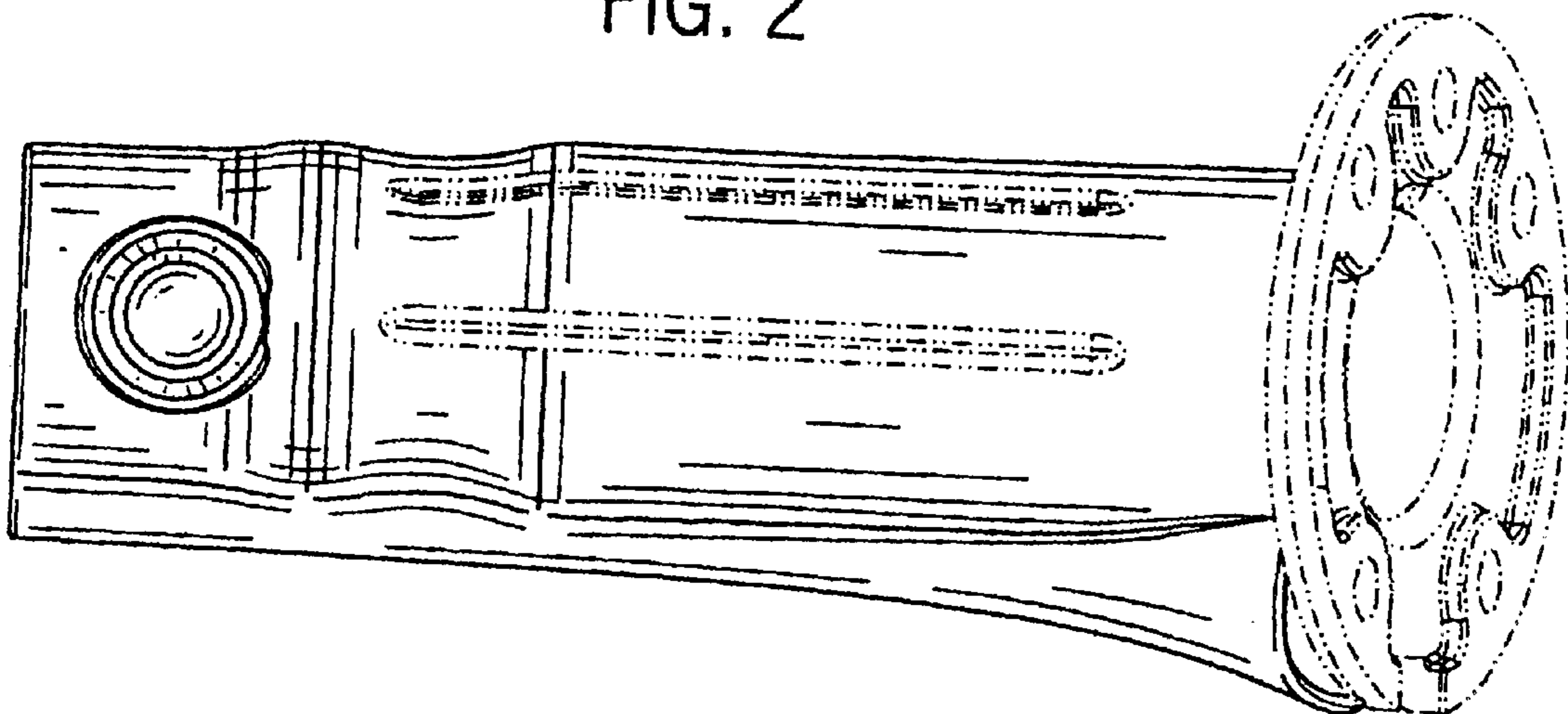

FIG. 3

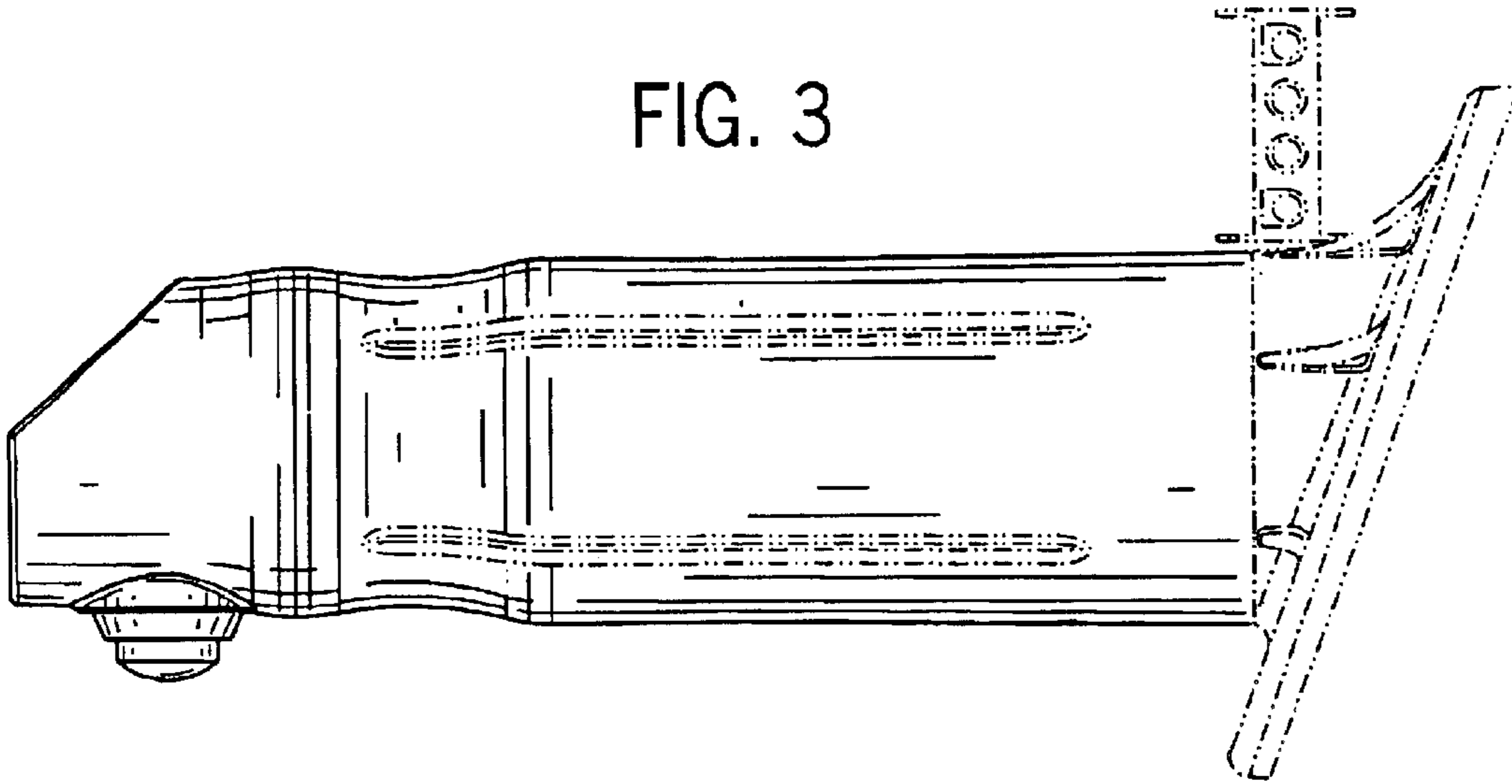
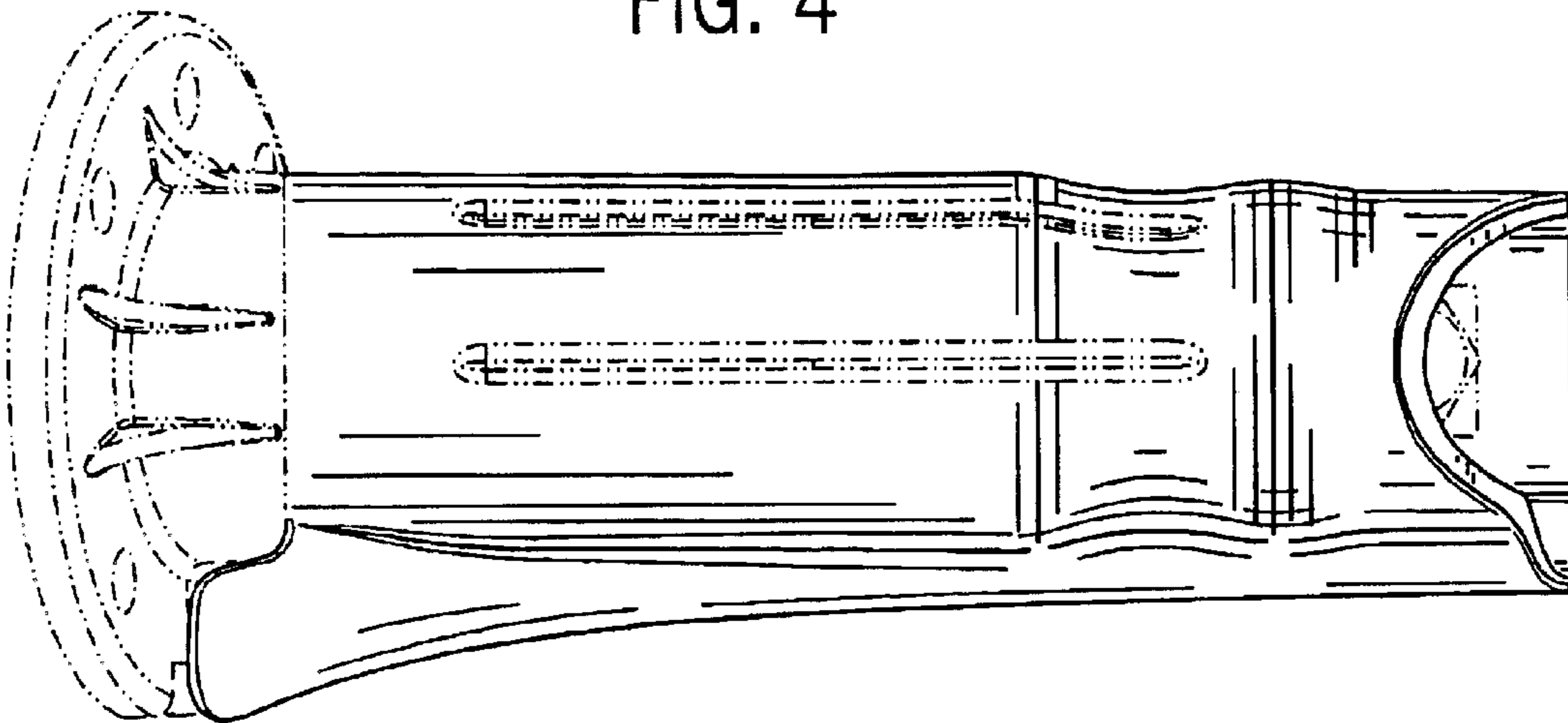

FIG. 4



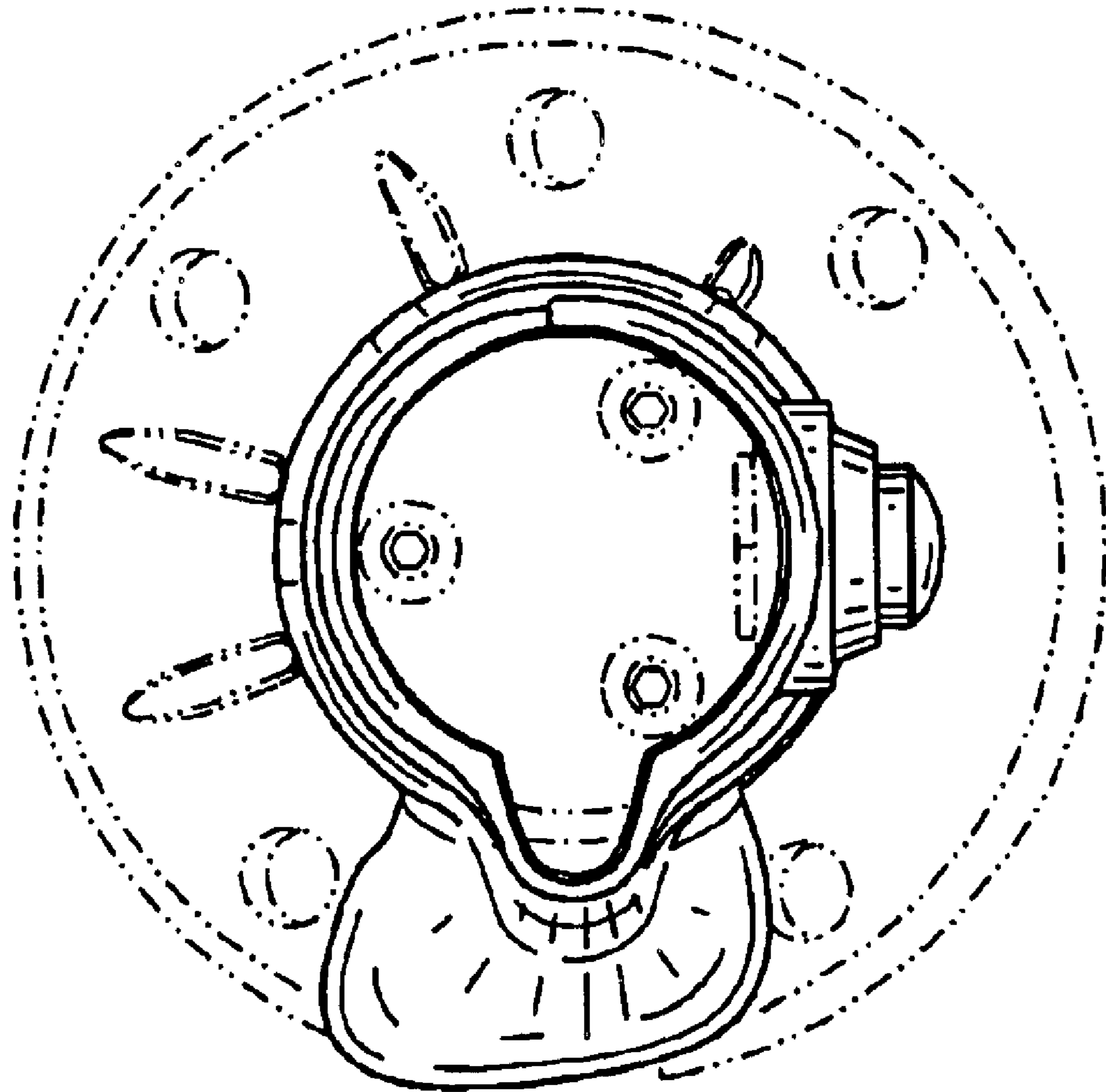

FIG. 5