

US00D499522S

(12) **United States Design Patent** (10) **Patent No.:** **US D499,522 S**
Ryan et al. (45) **Date of Patent:** **** Dec. 7, 2004**

(54) **BASE LEG FOR A MATERIAL HANDLING VEHICLE**

(75) Inventors: **H. Scott Ryan**, Skaneateles, NY (US);
Douglas M. Russell, Syracuse, NY (US);
Thomas W. Confer, Greene, NY (US);
Gregory W. Smiley, Greene, NY (US)

(73) Assignee: **The Raymond Corporation**, Greene, NY (US)

(**) Term: **14 Years**

(21) Appl. No.: **29/189,653**

(22) Filed: **Sep. 9, 2003**

(51) **LOC (7) Cl.** **12-05**

(52) **U.S. Cl.** **D34/35**

(58) **Field of Search** D34/28, 34-35;
180/89.12, 299, 315; 414/685, 679, 294;
187/222, 224

(56) **References Cited**

U.S. PATENT DOCUMENTS

D401,032 S	*	11/1998	Marcel	D34/35
D401,716 S	*	11/1998	Marcel	D34/34
D407,176 S	*	3/1999	Henshaw et al.	D34/34
6,089,353 A	*	7/2000	Bartels et al.	187/224

* cited by examiner

Primary Examiner—Holly Baynham
(74) *Attorney, Agent, or Firm*—Quarles & Brady LLP

(57) **CLAIM**

The ornamental design for a base leg for a material handling vehicle, as shown and described.

DESCRIPTION

In a preferred embodiment, the nature of this product is as a base leg useful in connection with a material handling vehicle.

FIG. 1 is a top, left, rear perspective view of a base leg for a material handling vehicle embodying our new design;
 FIG. 2 is a right side elevational view of the base leg shown in FIG. 1;
 FIG. 3 is a top plan view of the base leg shown in FIG. 1;
 FIG. 4 is a rear elevational view of the base leg shown in FIG. 1;
 FIG. 5 is a front elevational view of the base leg shown in FIG. 1;
 FIG. 6 is left side elevational view of the base leg shown in FIG. 1;
 FIG. 7 is a top, left, rear perspective view of a mirror image of the base leg for a material handling vehicle shown in FIG. 1;
 FIG. 8 is a top, left, rear perspective view of a second embodiment of a base leg for a material handling vehicle embodying our new design;
 FIG. 9 is a right side elevational view of the base leg shown in FIG. 8;
 FIG. 10 is a top plan view of the base leg shown in FIG. 8;
 FIG. 11 is a rear elevational view of the base leg shown in FIG. 8;
 FIG. 12 is a front elevational view of the base leg shown in FIG. 8;
 FIG. 13 is left side elevational view of the base leg shown in FIG. 8;
 FIG. 14 is a top, left, rear perspective view of a mirror image of the base leg for a material handling vehicle shown in FIG. 8;
 FIG. 15 is a top, left, rear perspective view of a third embodiment of a base leg for a material handling vehicle embodying our new design;
 FIG. 16 is a right side elevational view of the base leg shown in FIG. 15;
 FIG. 17 is a top plan view of the base leg shown in FIG. 16;
 FIG. 18 is a rear elevational view of the base leg shown in FIG. 15;
 FIG. 19 is a front elevational view of the base leg shown in FIG. 15;
 FIG. 20 is left side elevational view of the base leg shown in FIG. 15;
 FIG. 21 is a top, left, rear perspective view of a mirror image of the base leg for a material handling vehicle shown in FIG. 15;

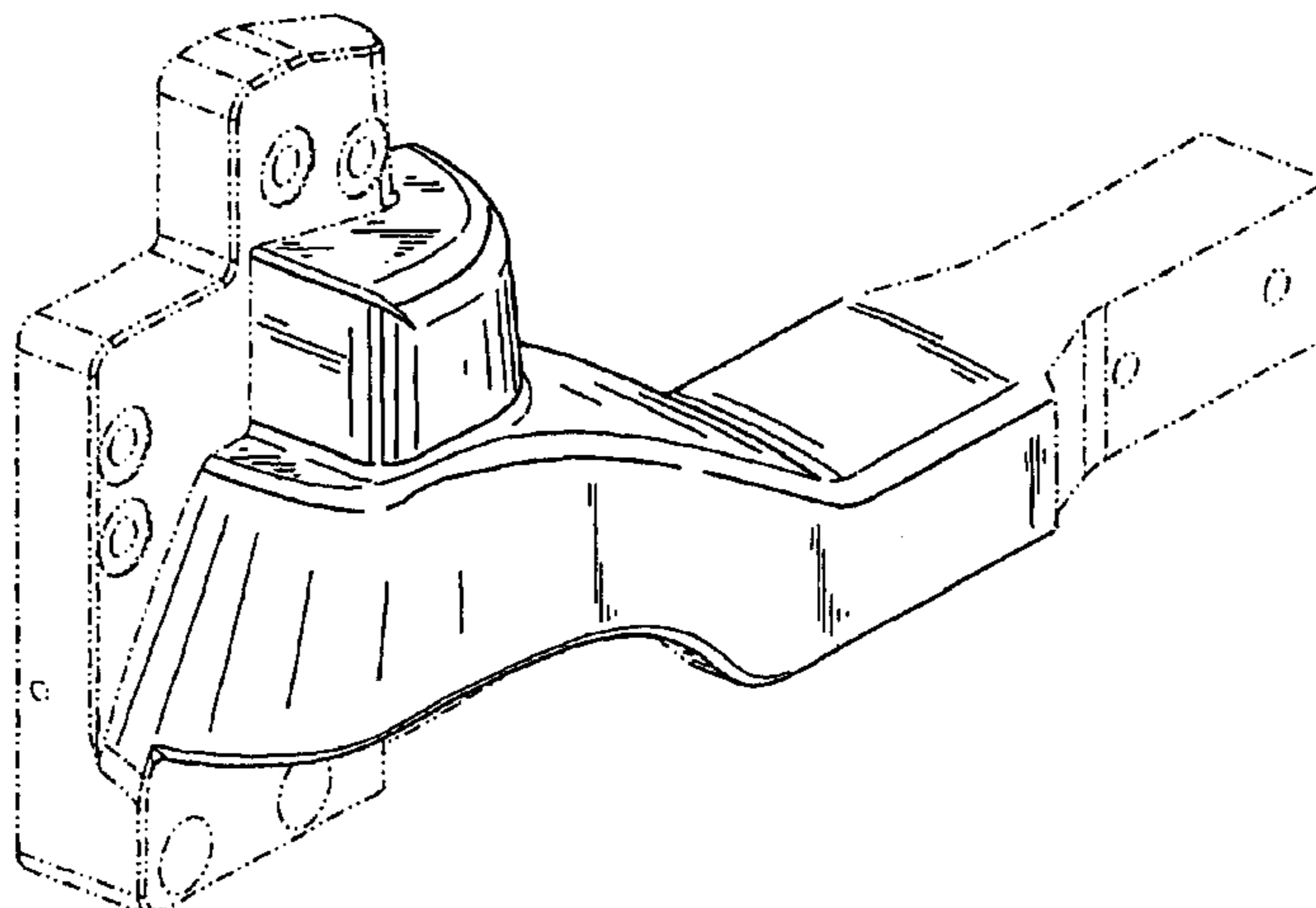

FIG. 22 is a top, left, rear perspective view of a fourth embodiment of a base leg for a material handling vehicle embodying our new design;

FIG. 23 is a right side elevational view of the base leg shown in FIG. 22;

FIG. 24 is a top plan view of the base leg shown in FIG. 22;

FIG. 25 is a rear elevational view of the base leg shown in FIG. 22;

FIG. 26 is a front elevational view of the base leg shown in FIG. 22;

FIG. 27 is left side elevational view of the base leg shown in FIG. 22; and,

FIG. 28 is a top, left, rear perspective view of a mirror image of the base leg for a material handling vehicle shown in FIG. 22.

The broken lines immediately adjacent the shaded areas represent the bounds of the claim and all other broken lines are for illustrative purposes only. None of the broken lines form a part of the claimed design.

1 Claim, 12 Drawing Sheets

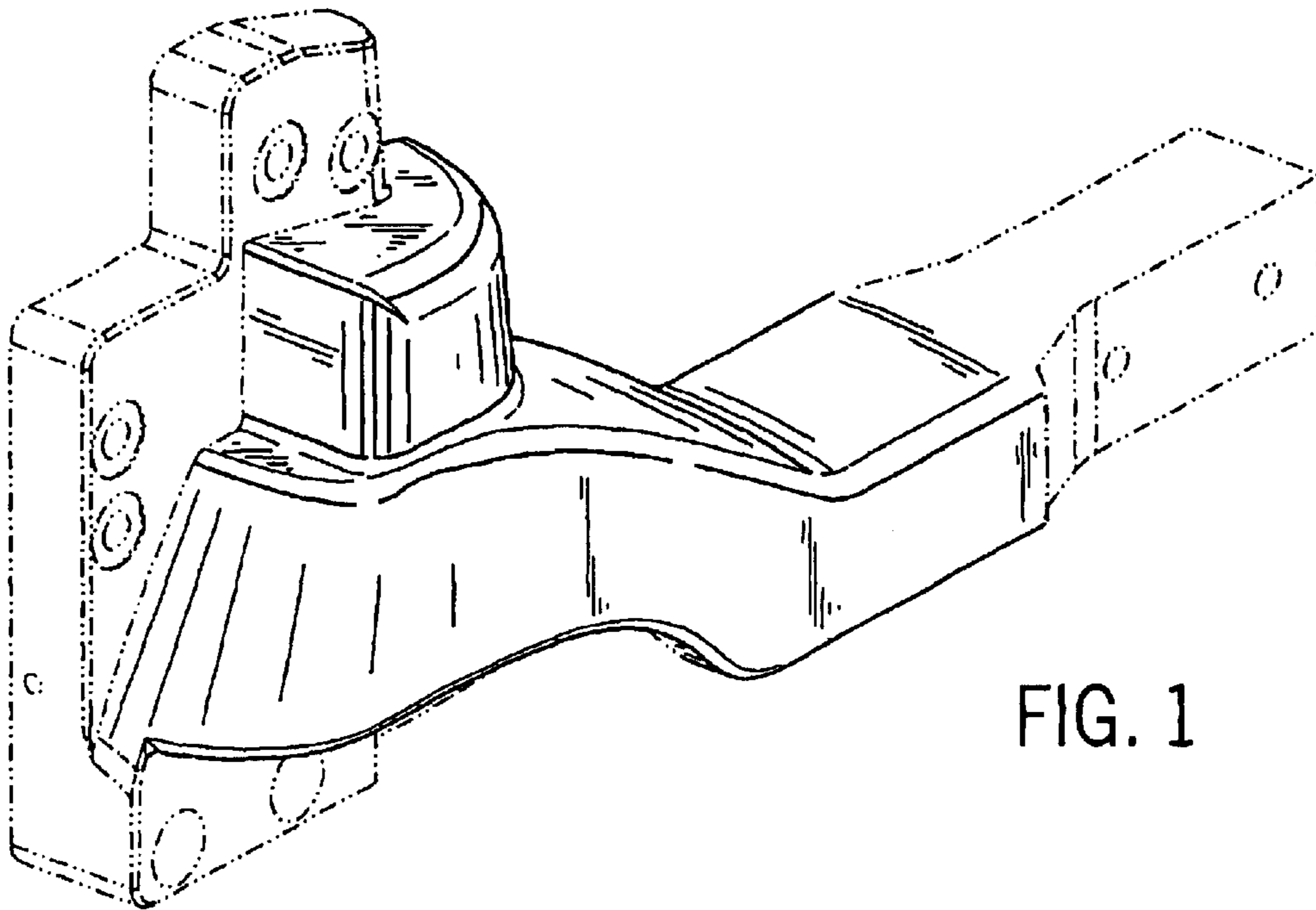

FIG. 1

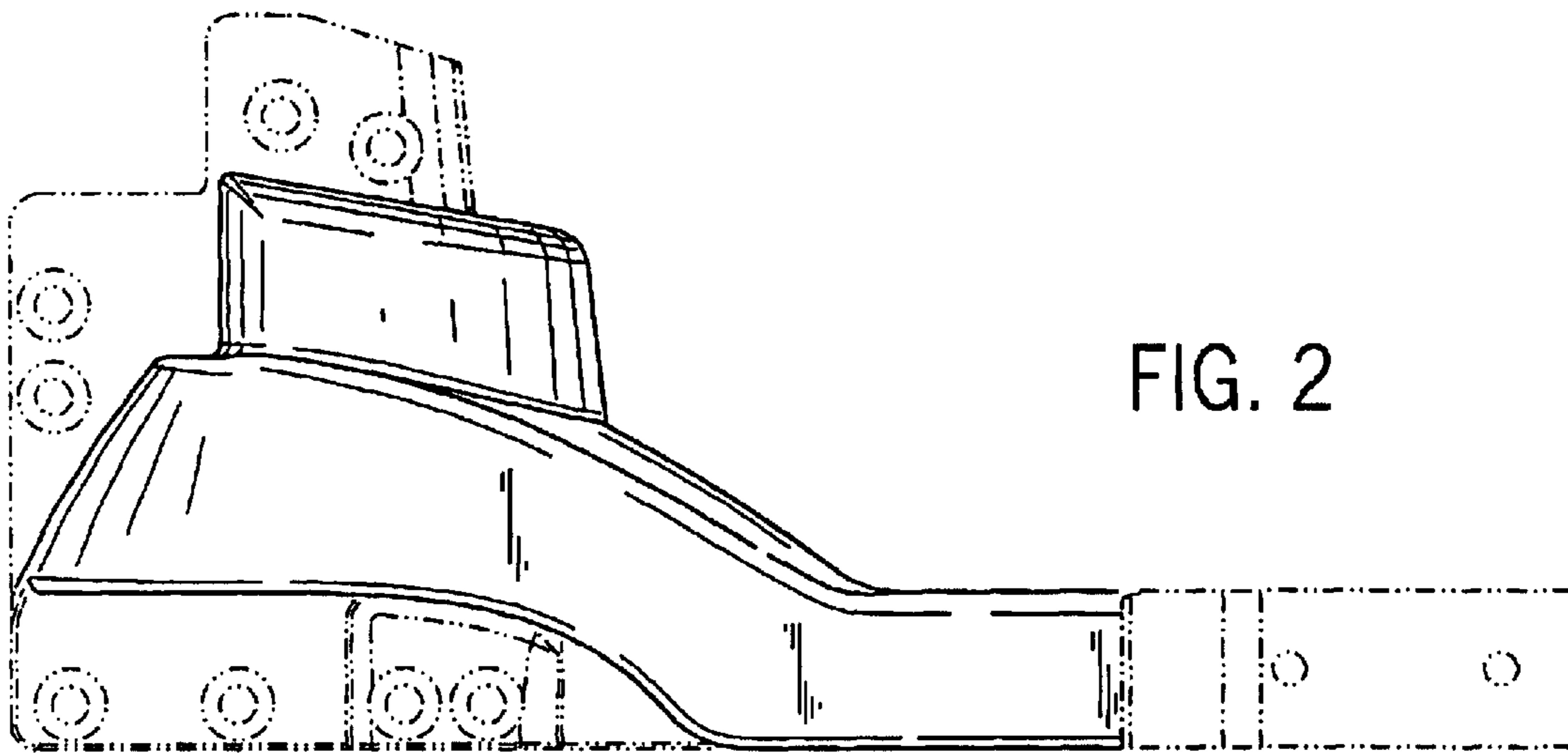

FIG. 2

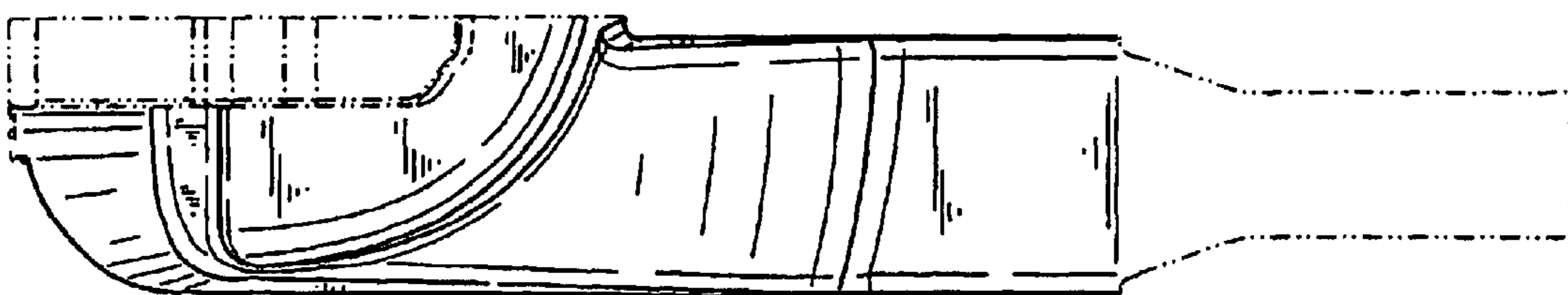

FIG. 3

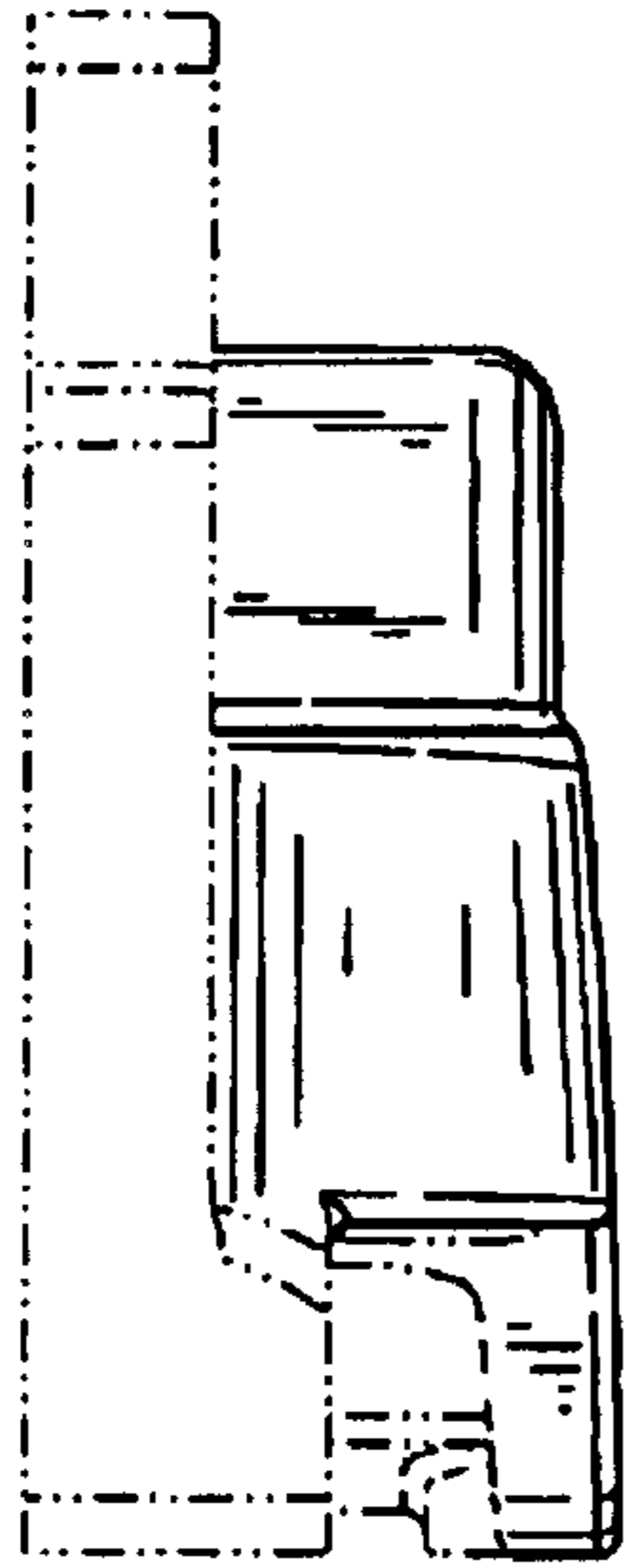

FIG. 4

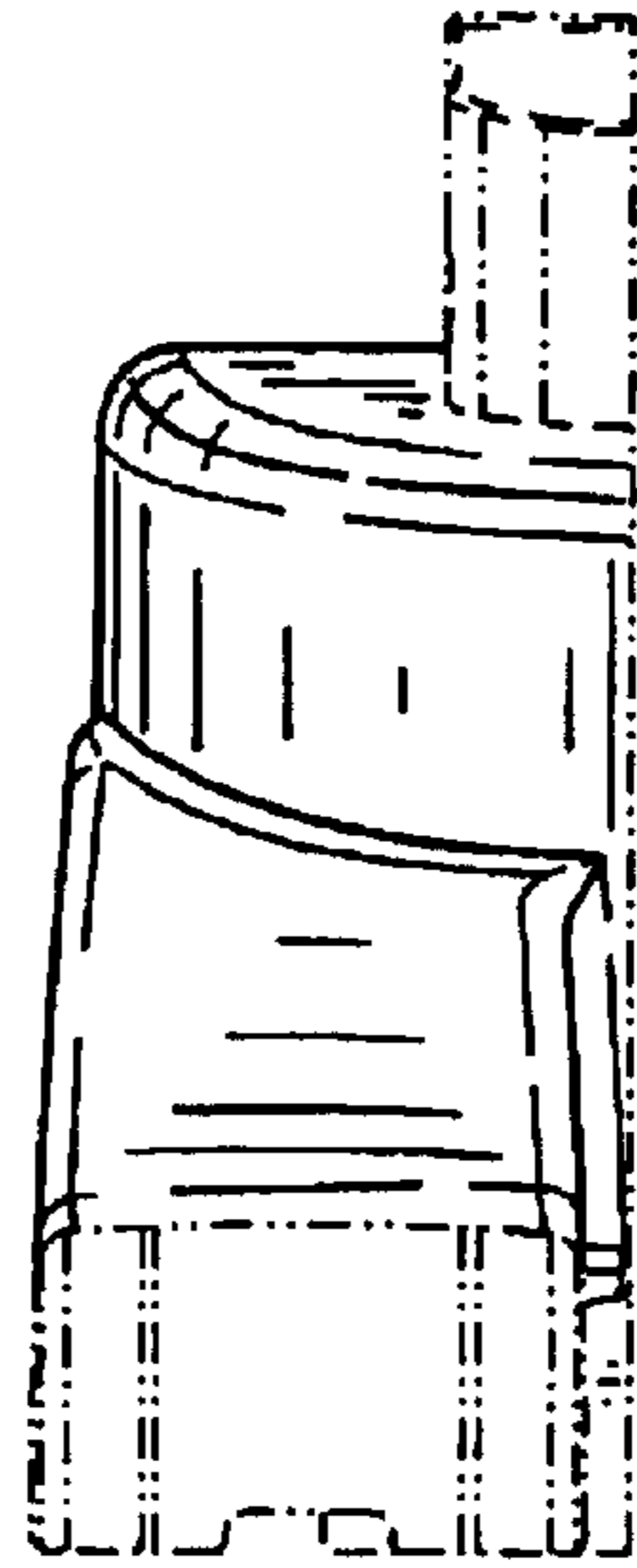

FIG. 5

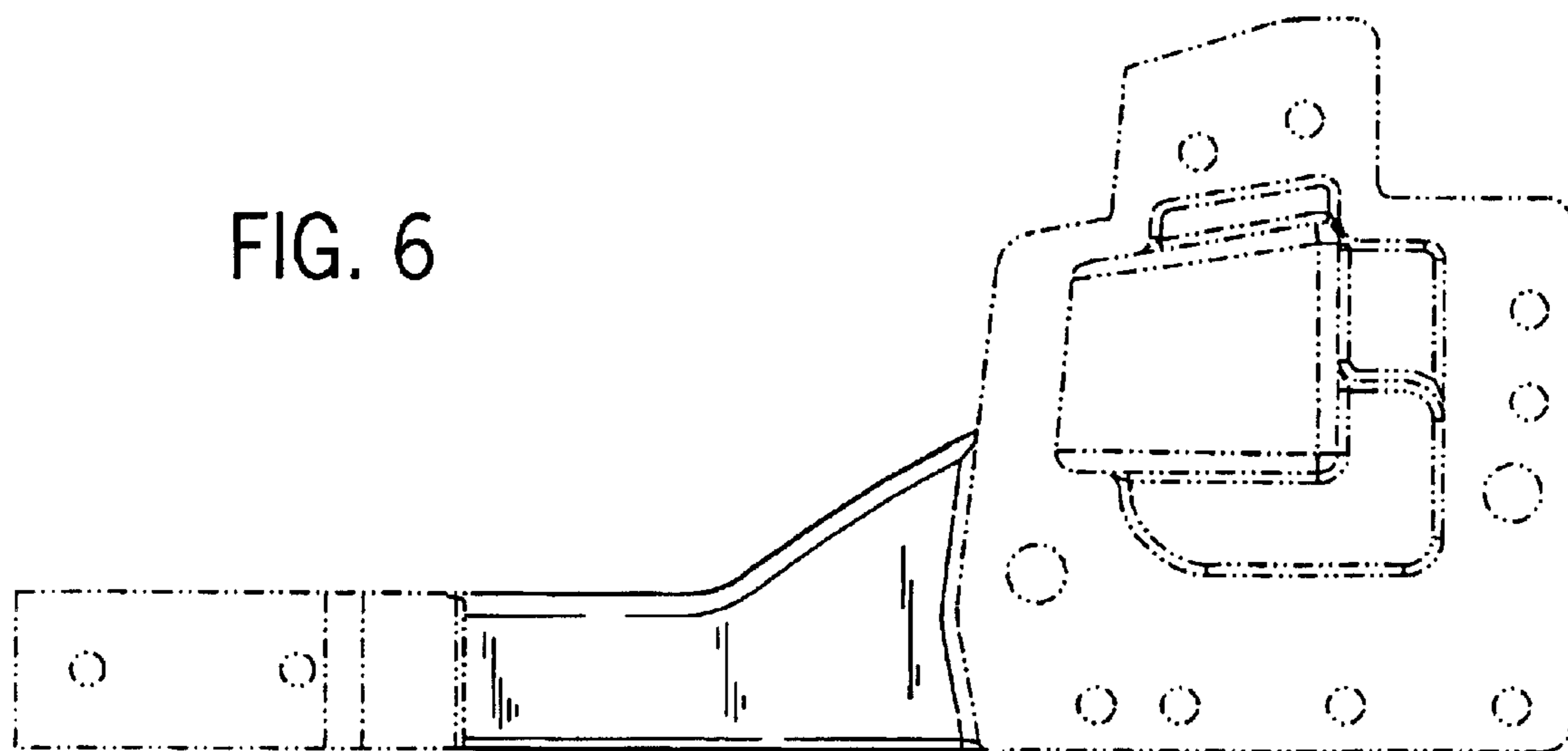

FIG. 6

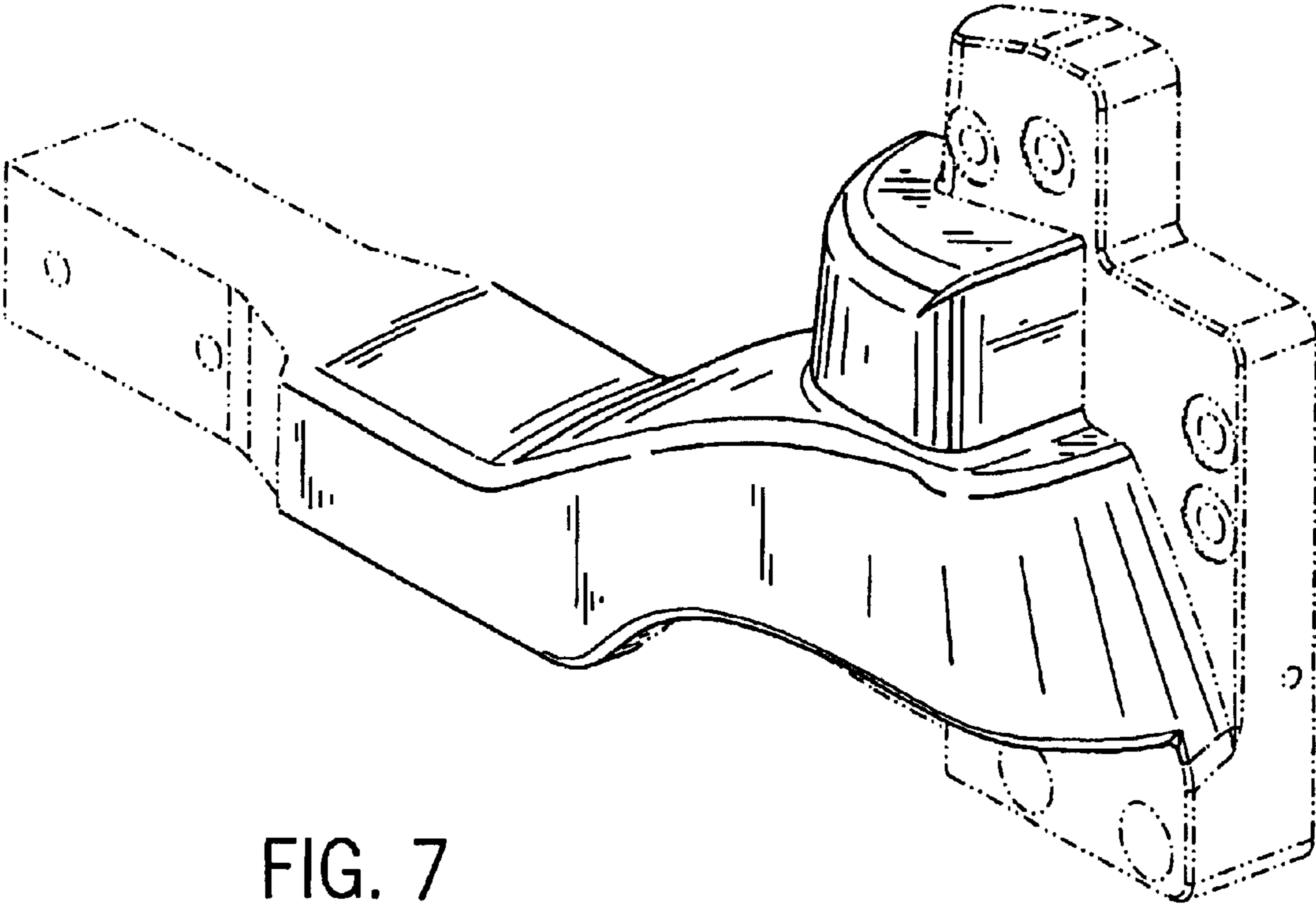

FIG. 7

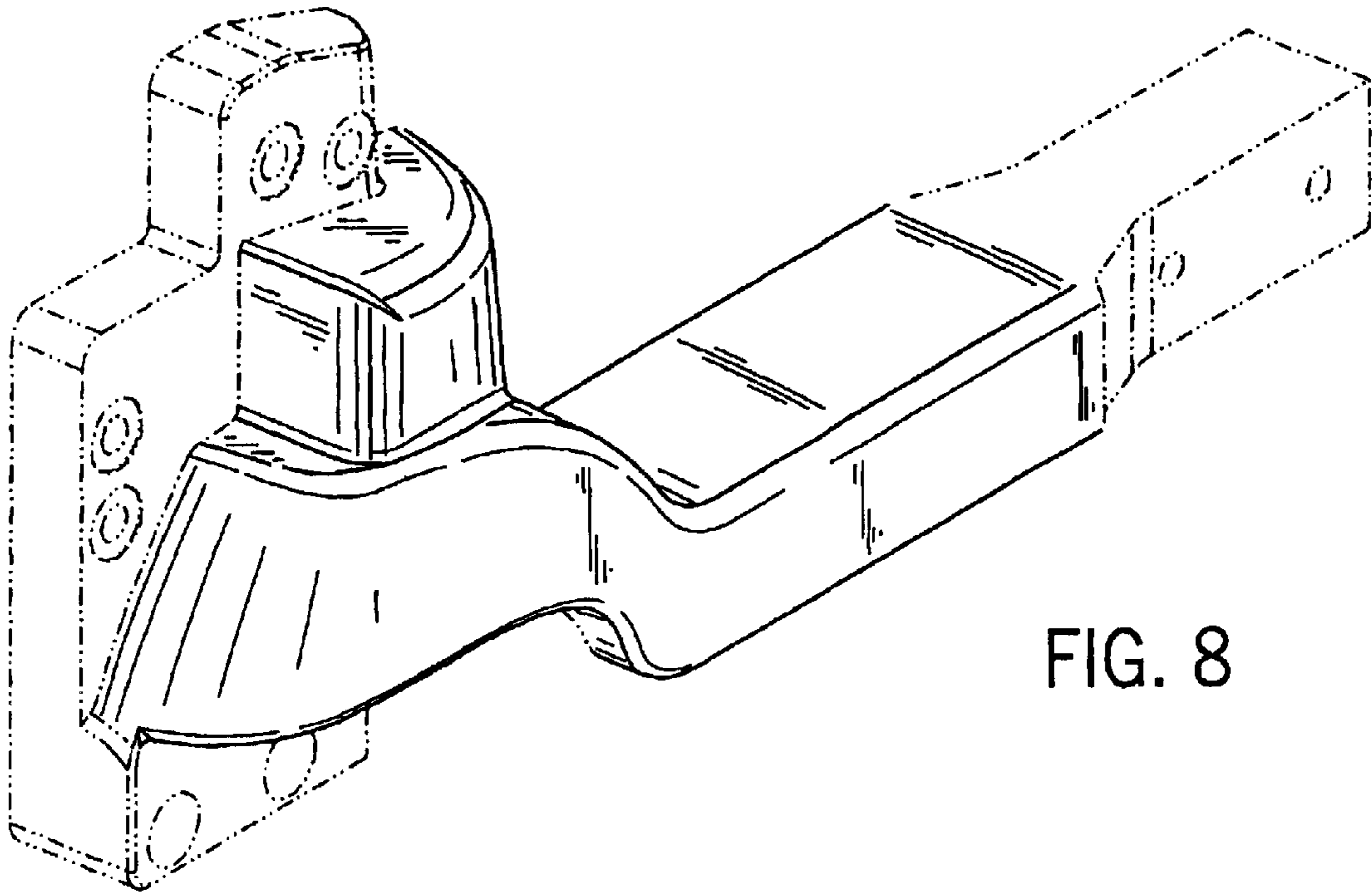

FIG. 8

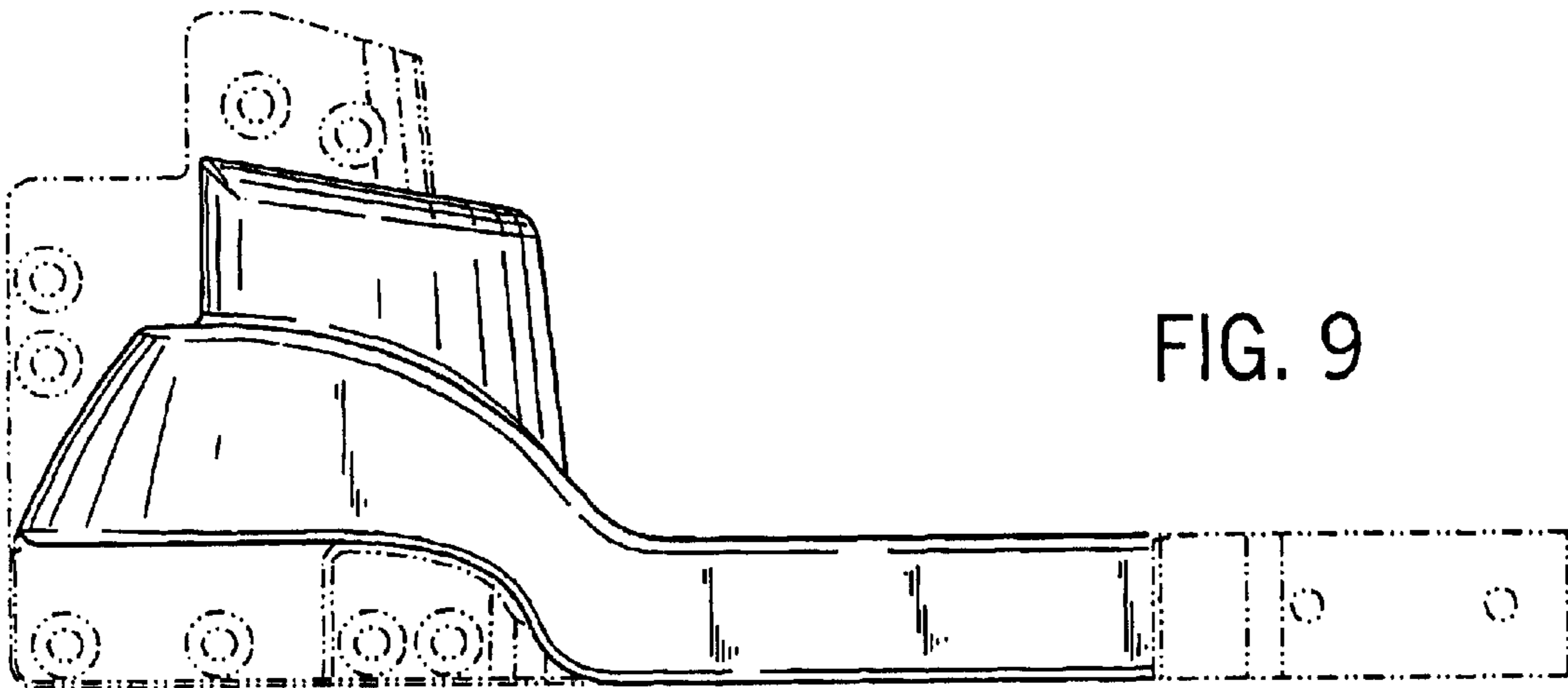

FIG. 9

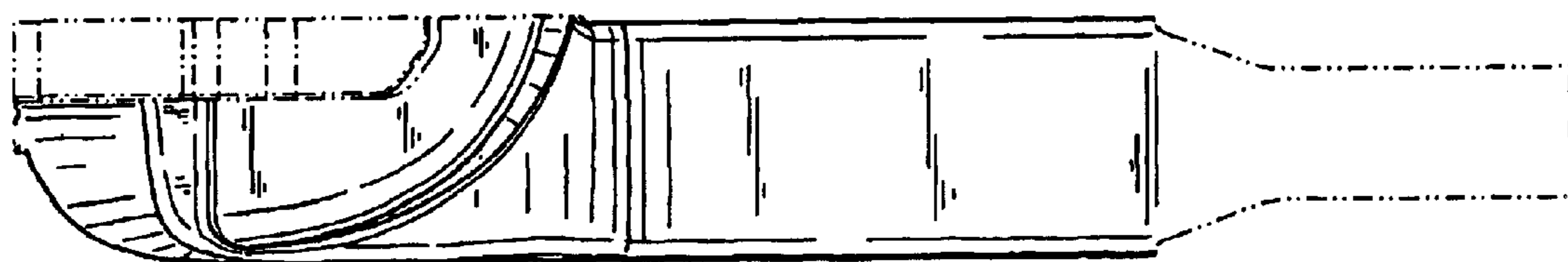

FIG. 10

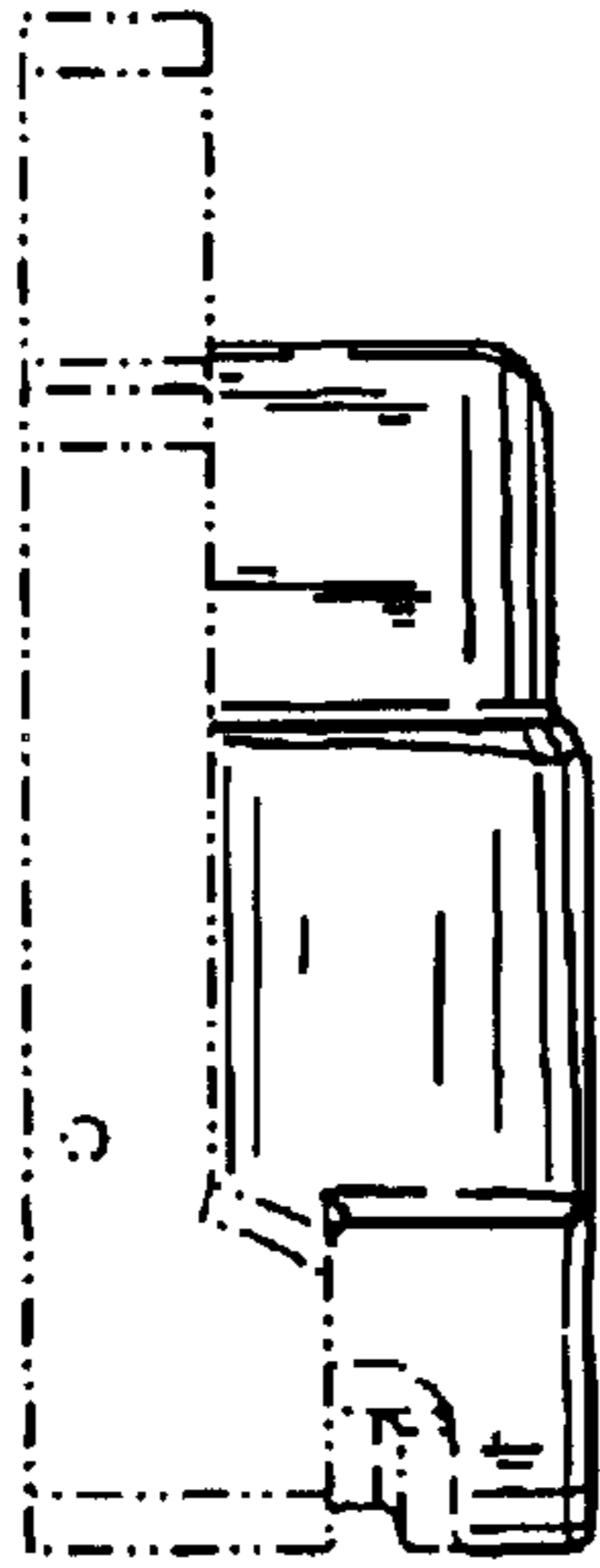

FIG. 11

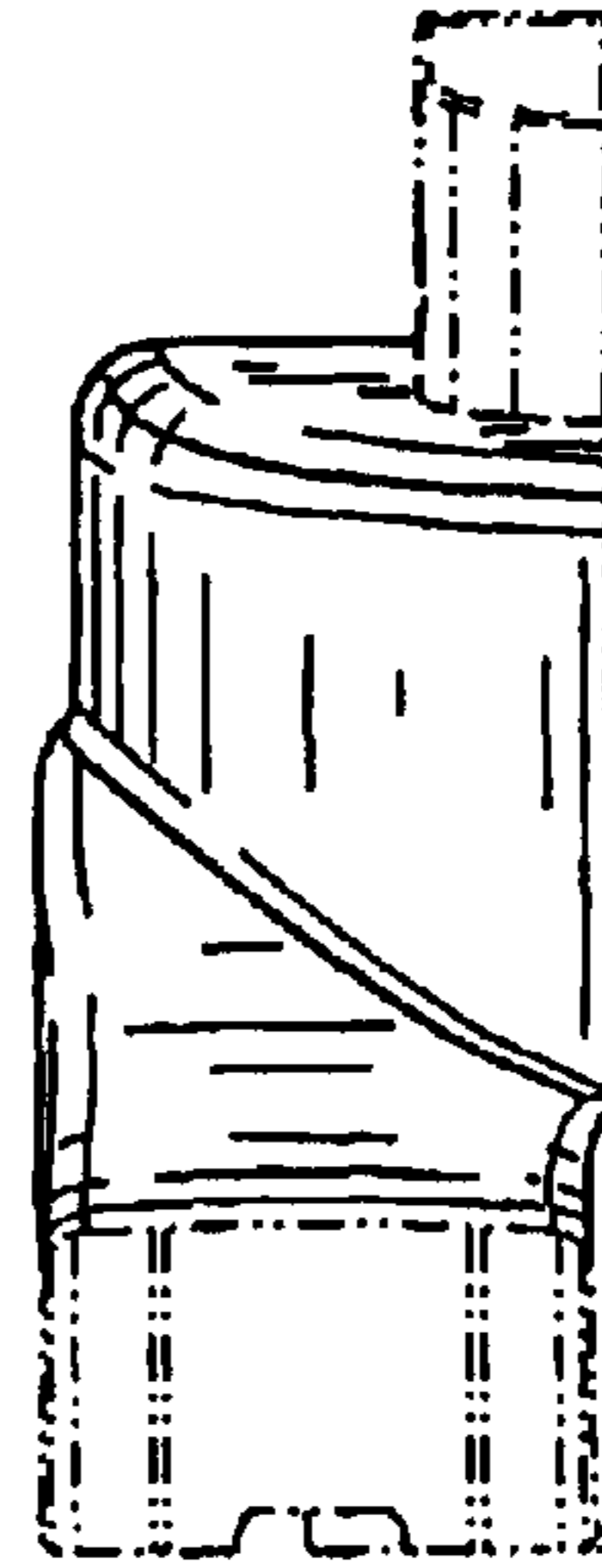
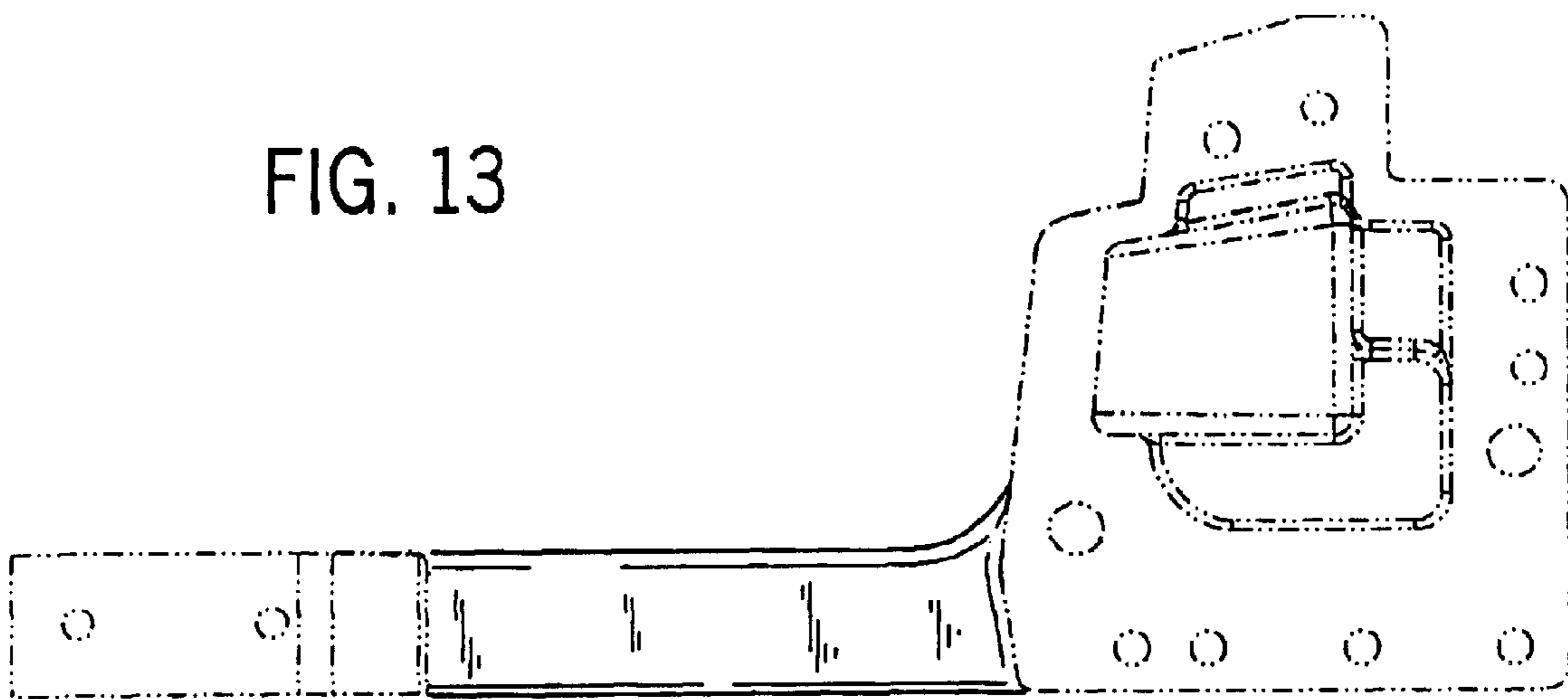

FIG. 12

FIG. 13



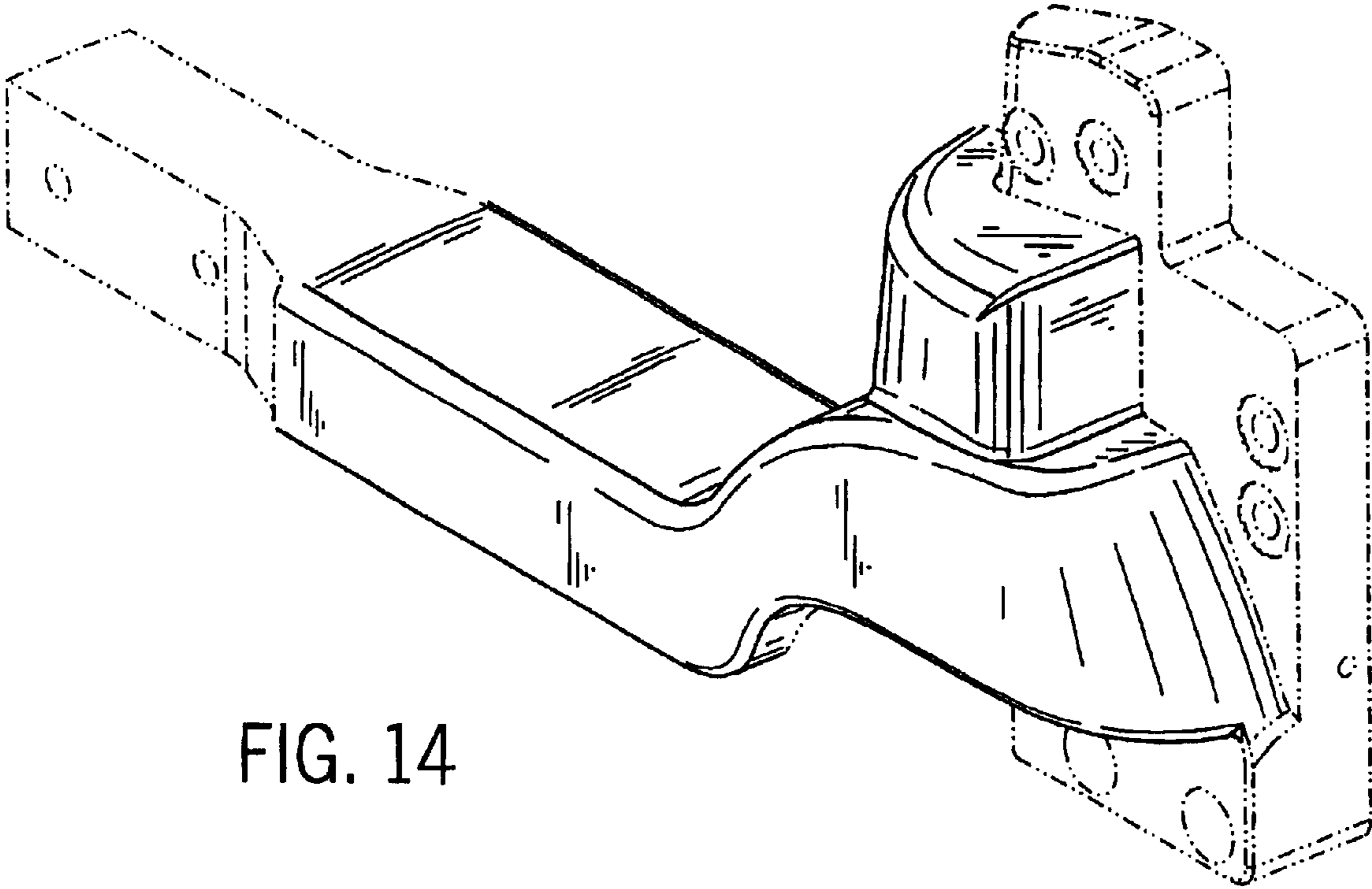

FIG. 14

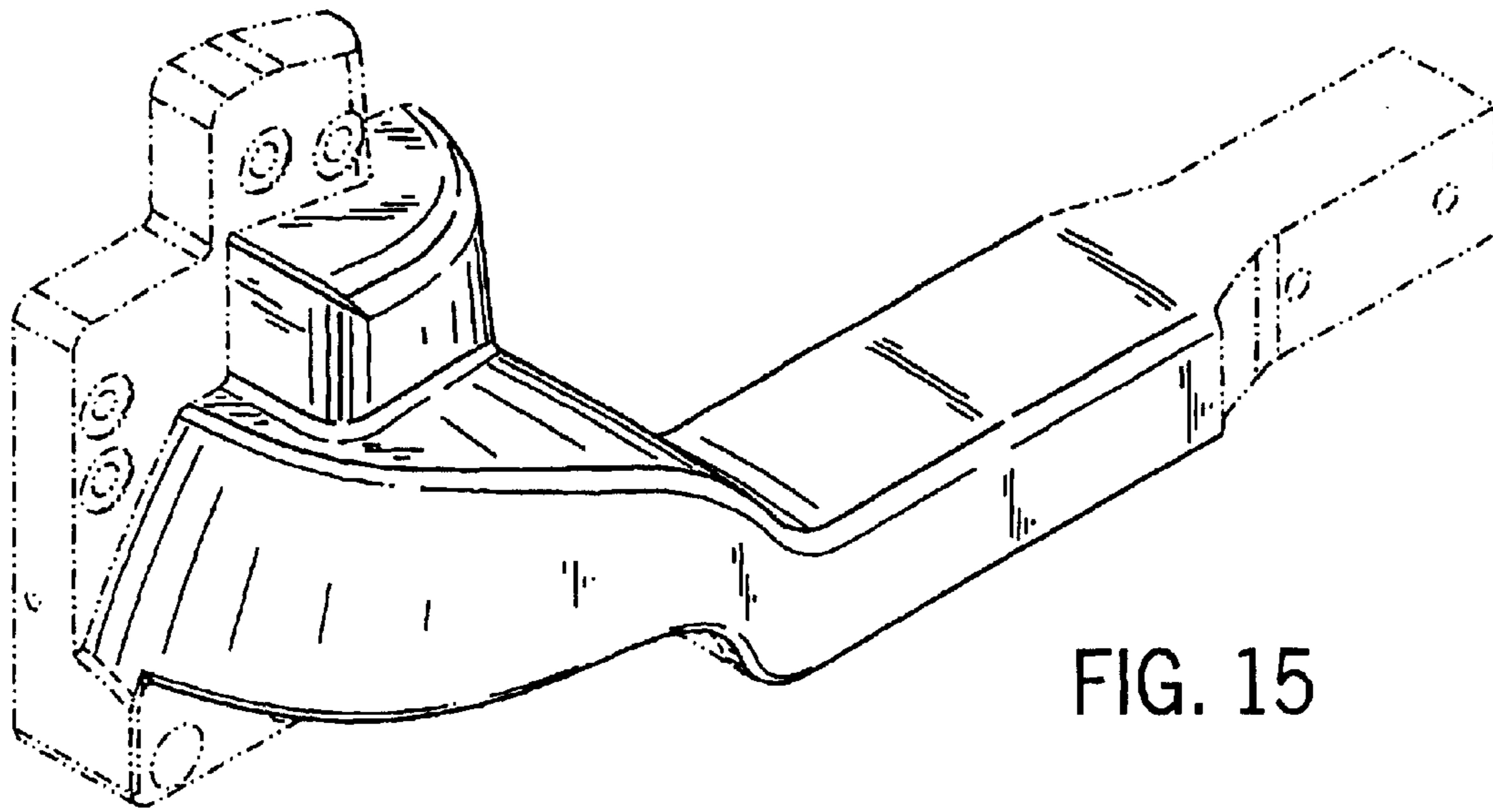

FIG. 15

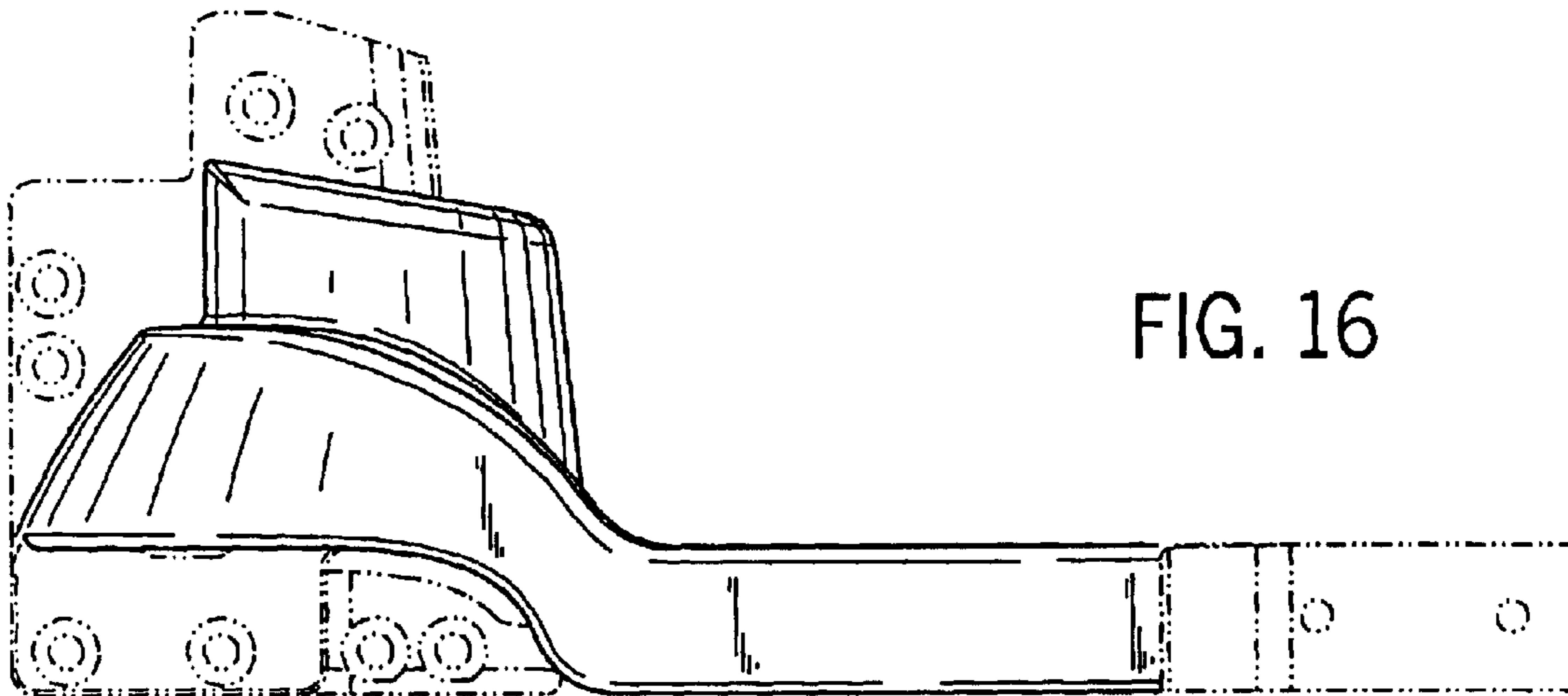

FIG. 16

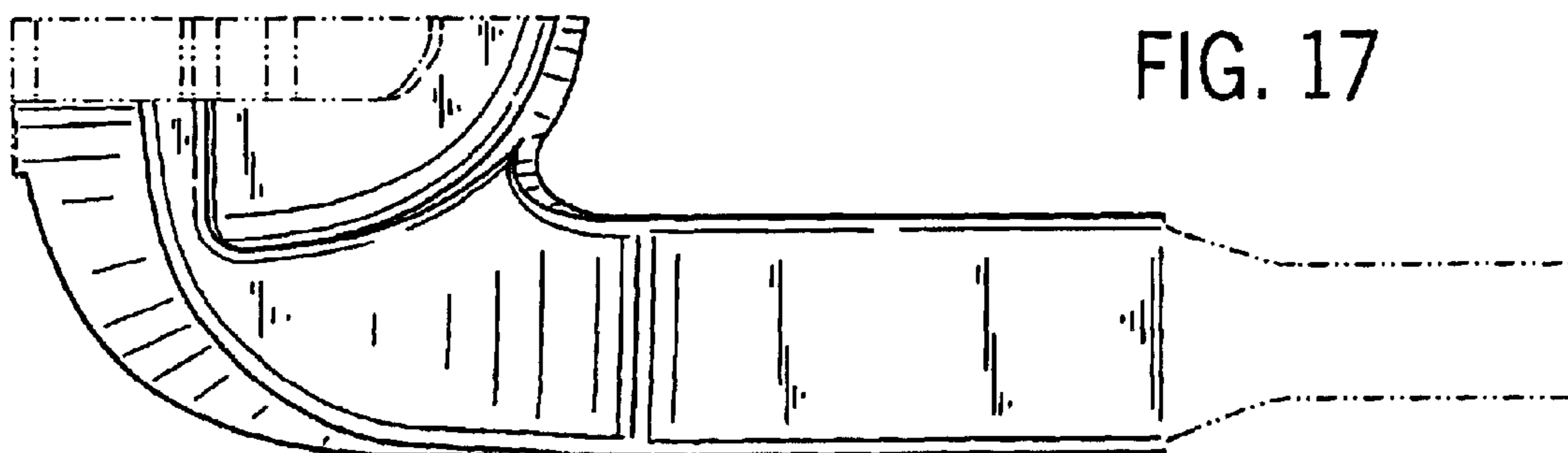

FIG. 17

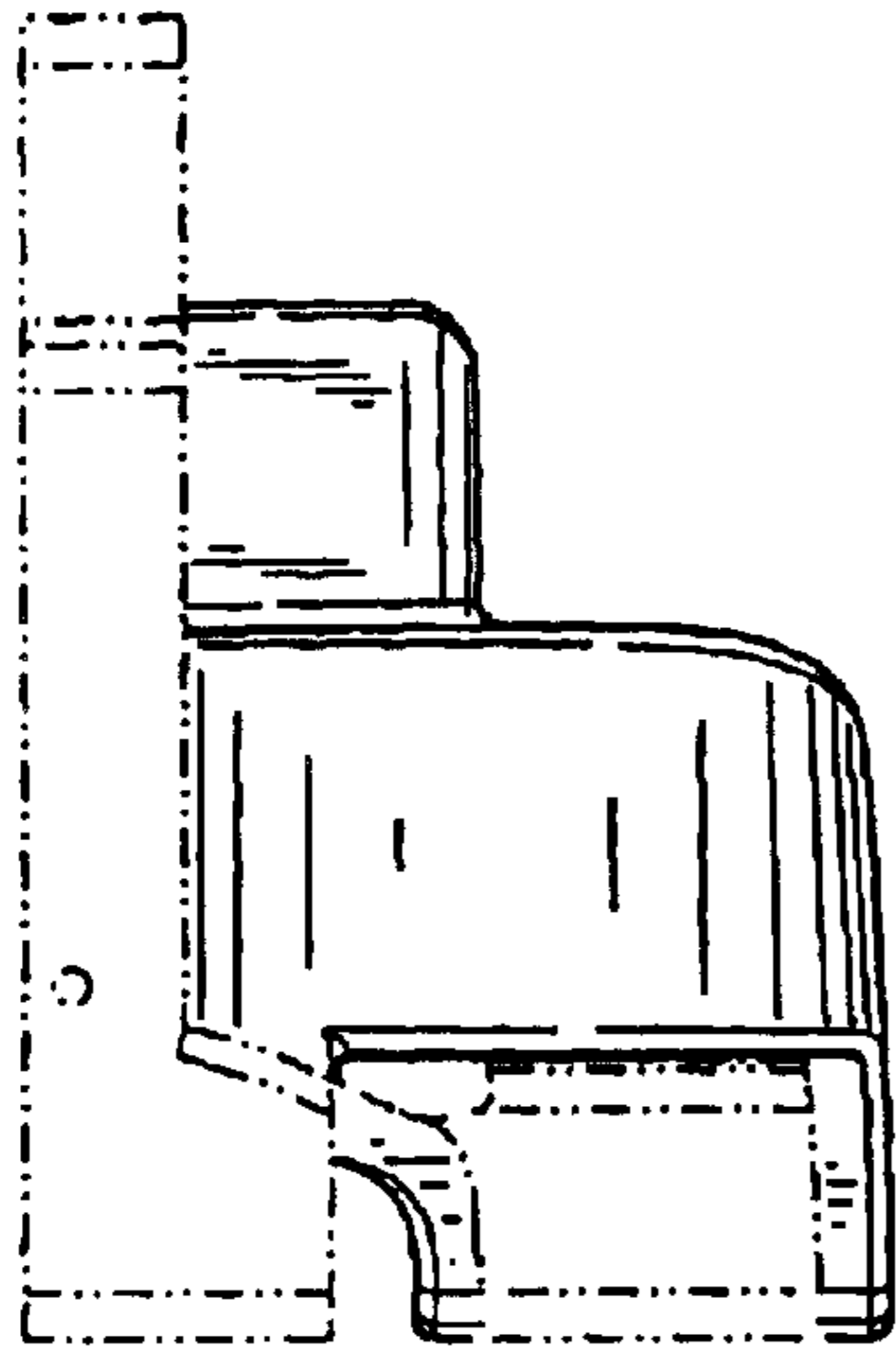

FIG. 18

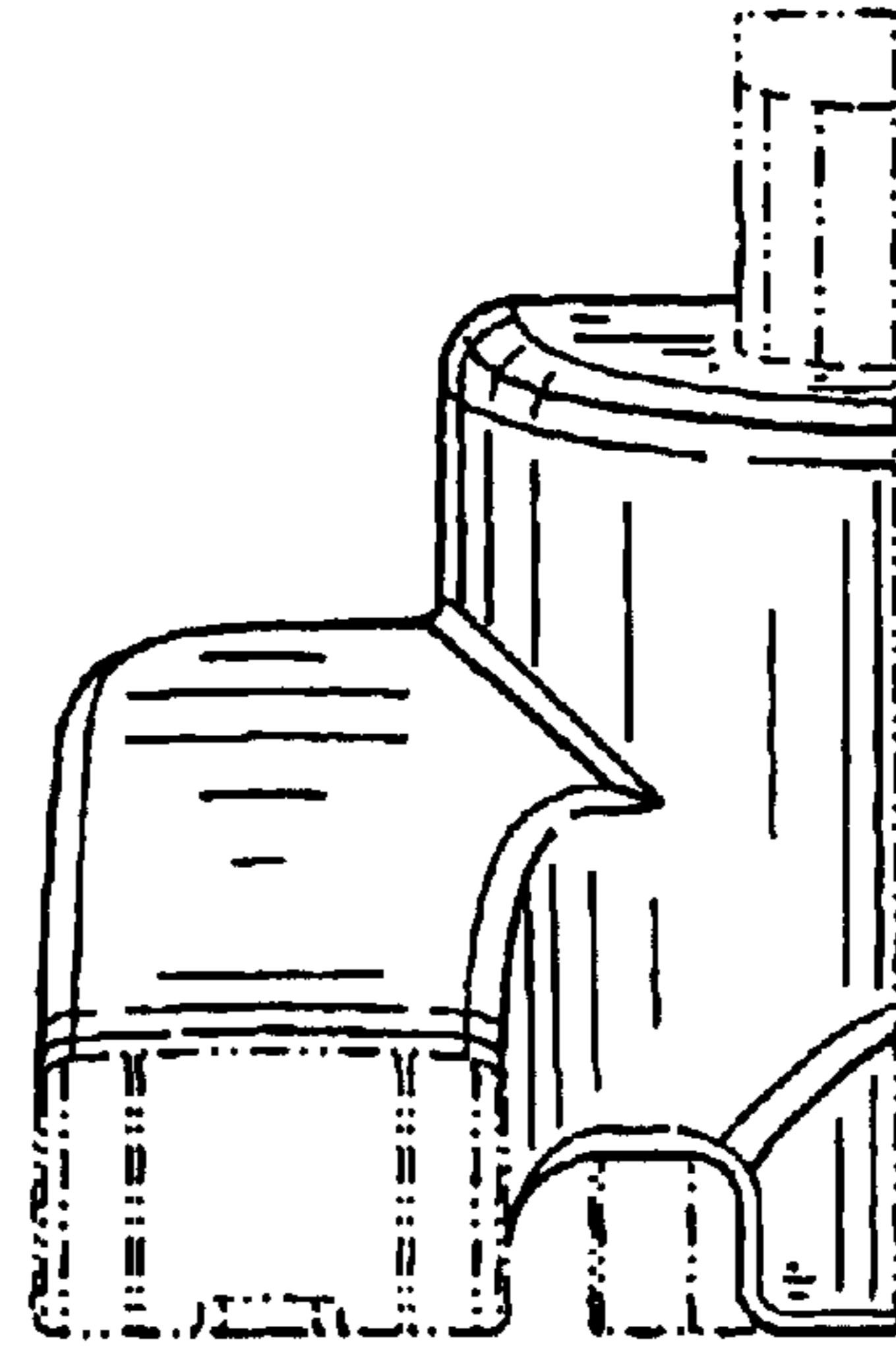

FIG. 19

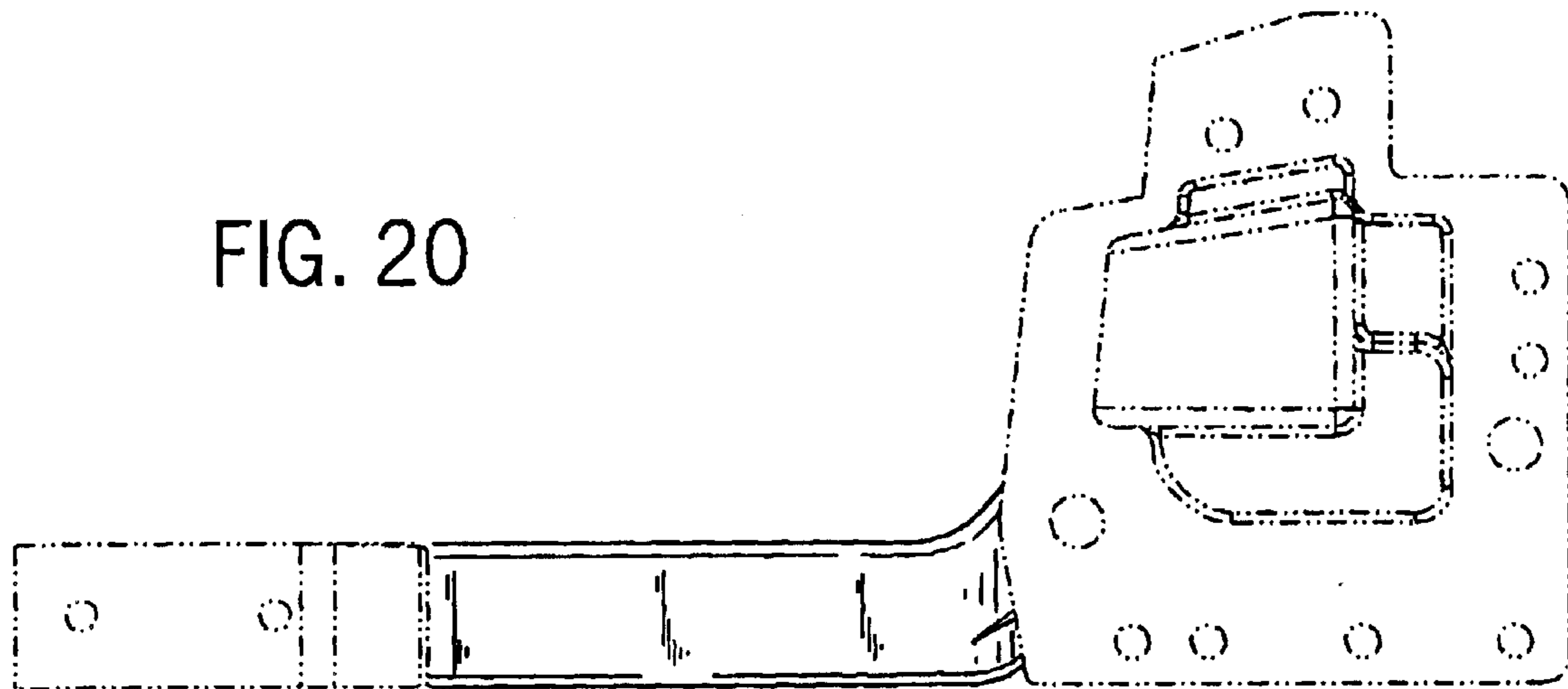

FIG. 20

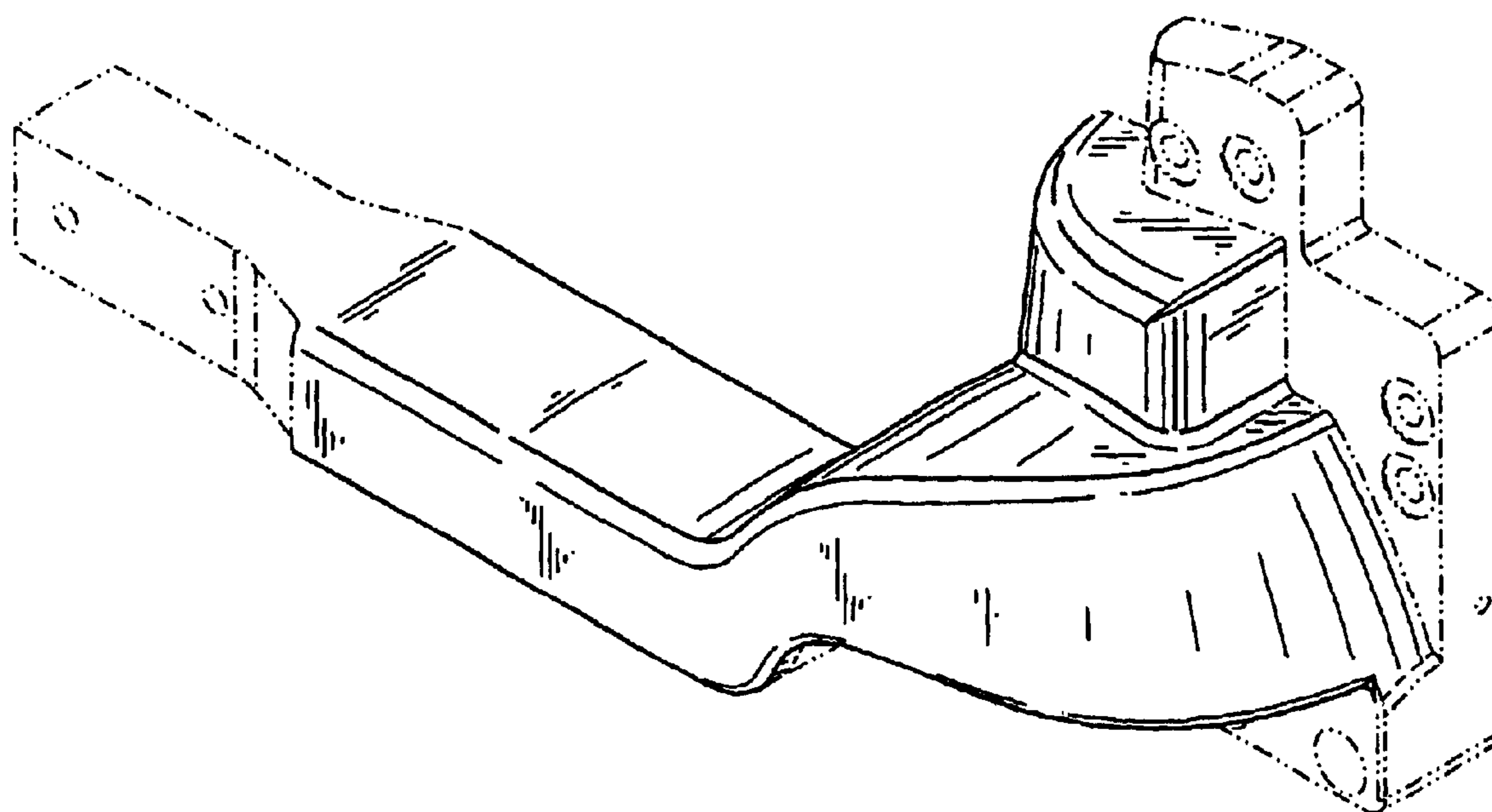

FIG. 21

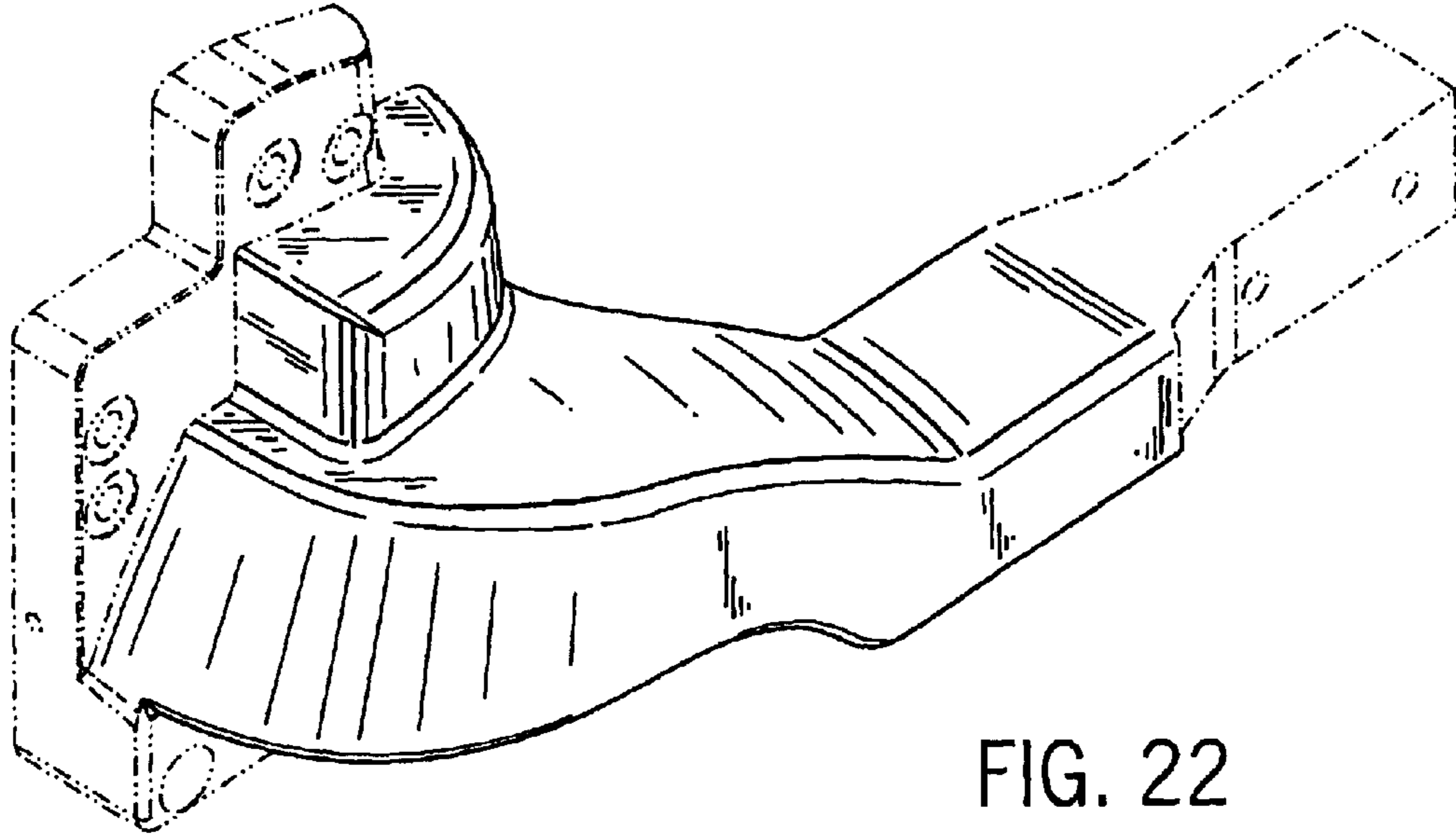

FIG. 22

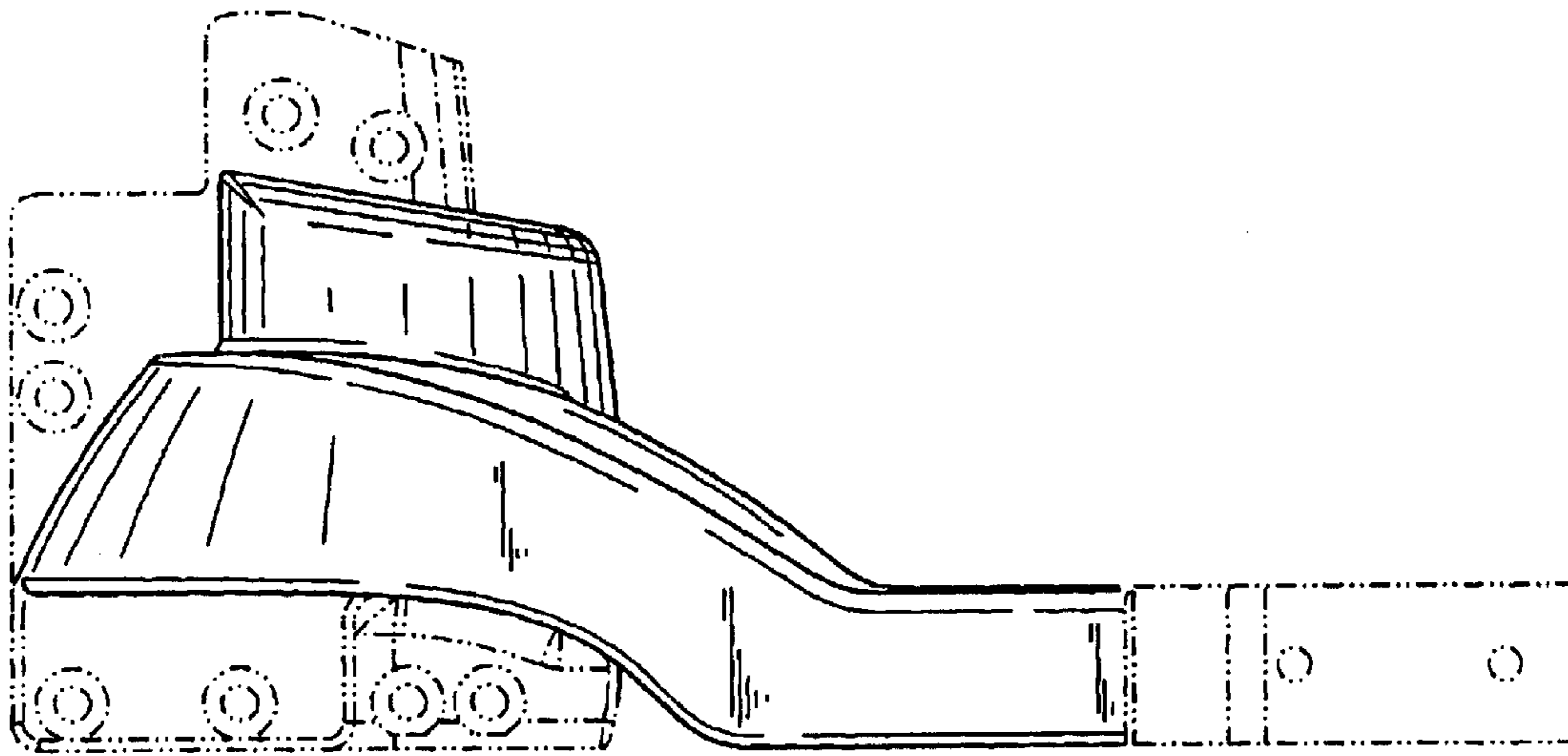

FIG. 23

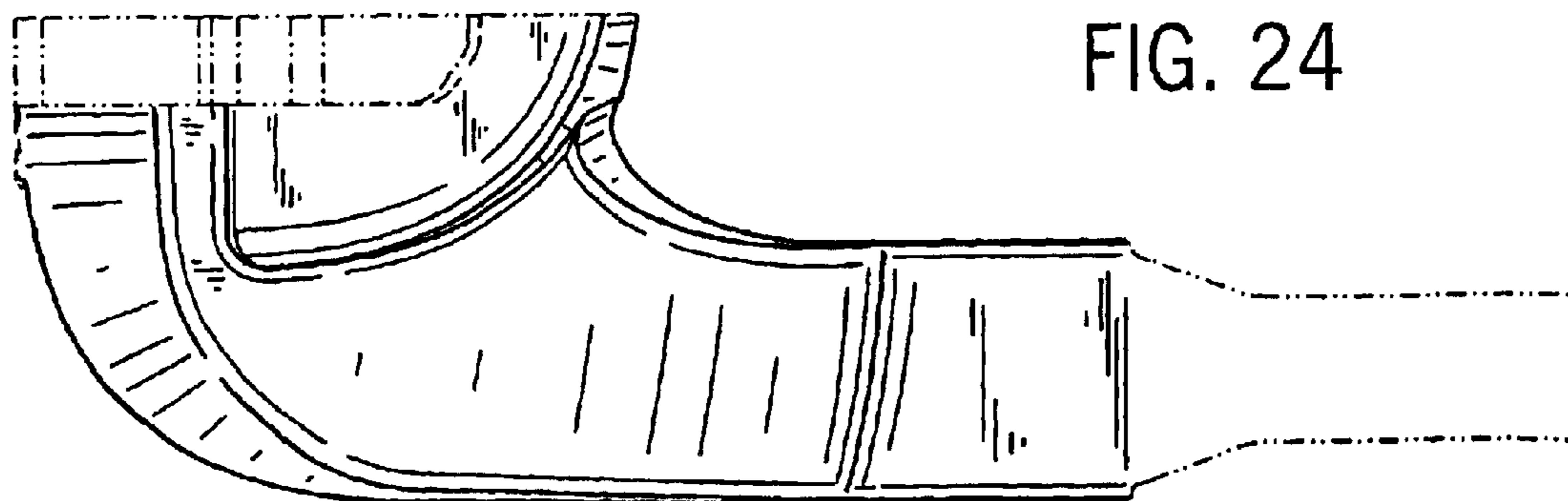

FIG. 24

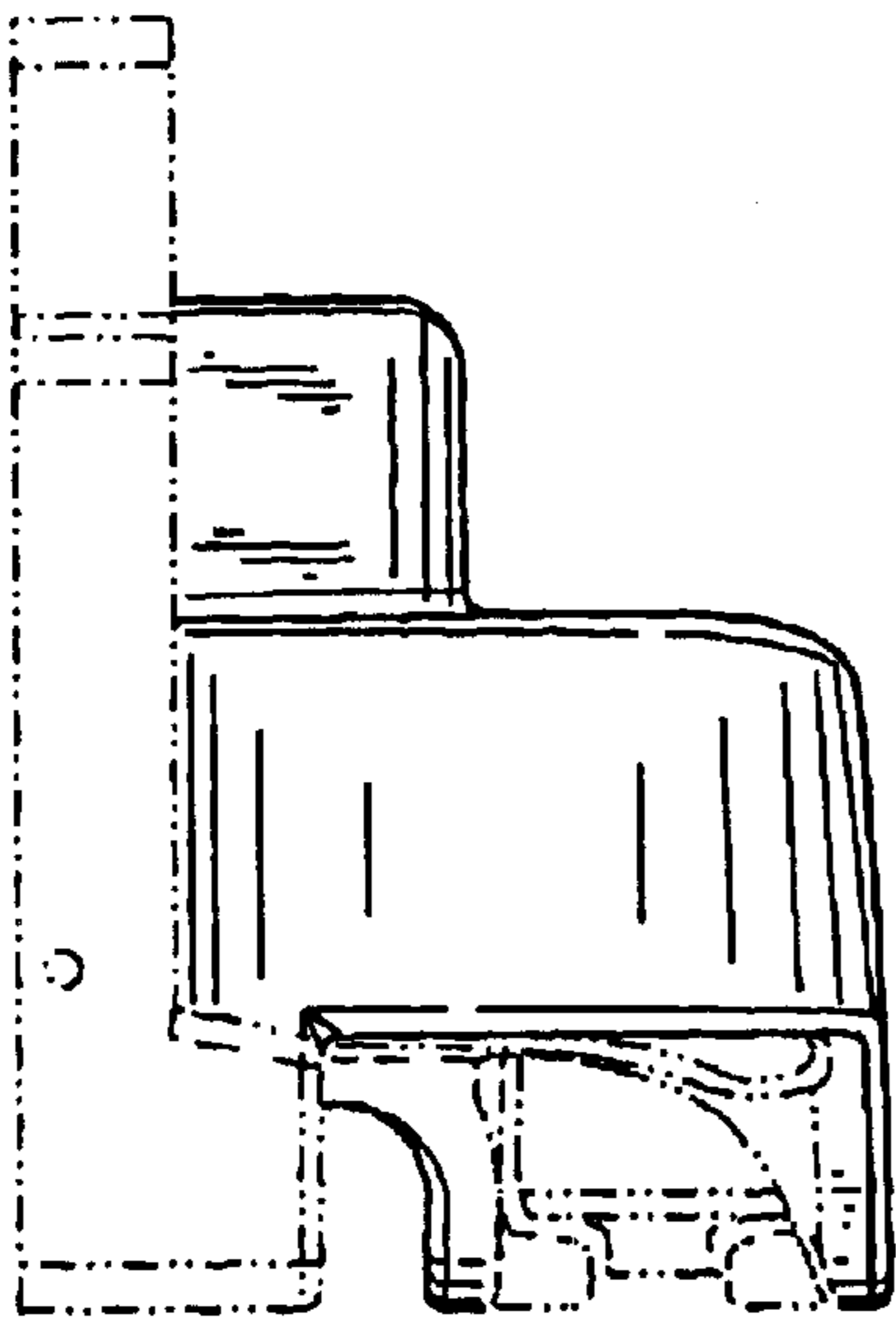

FIG. 25

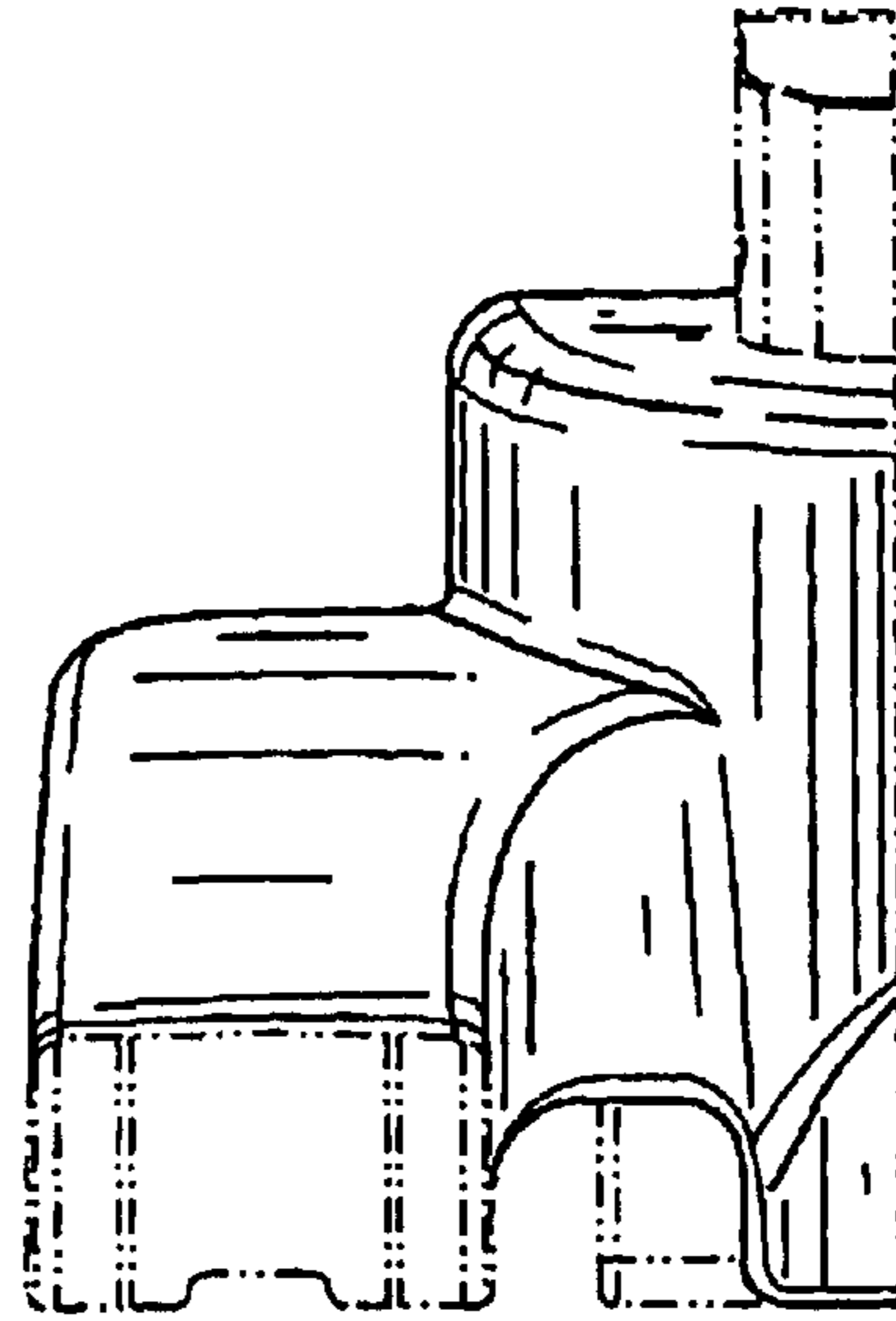

FIG. 26

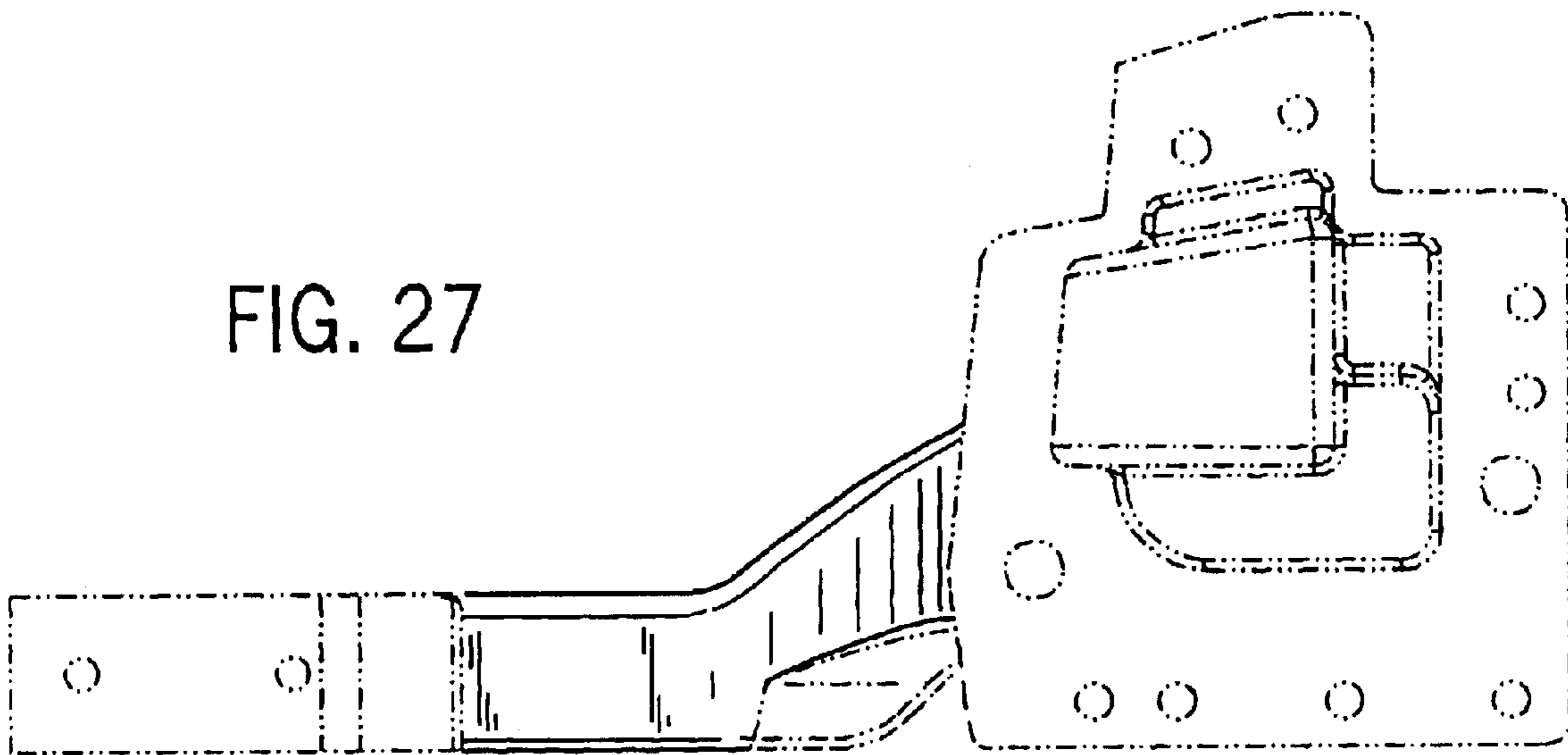

FIG. 27

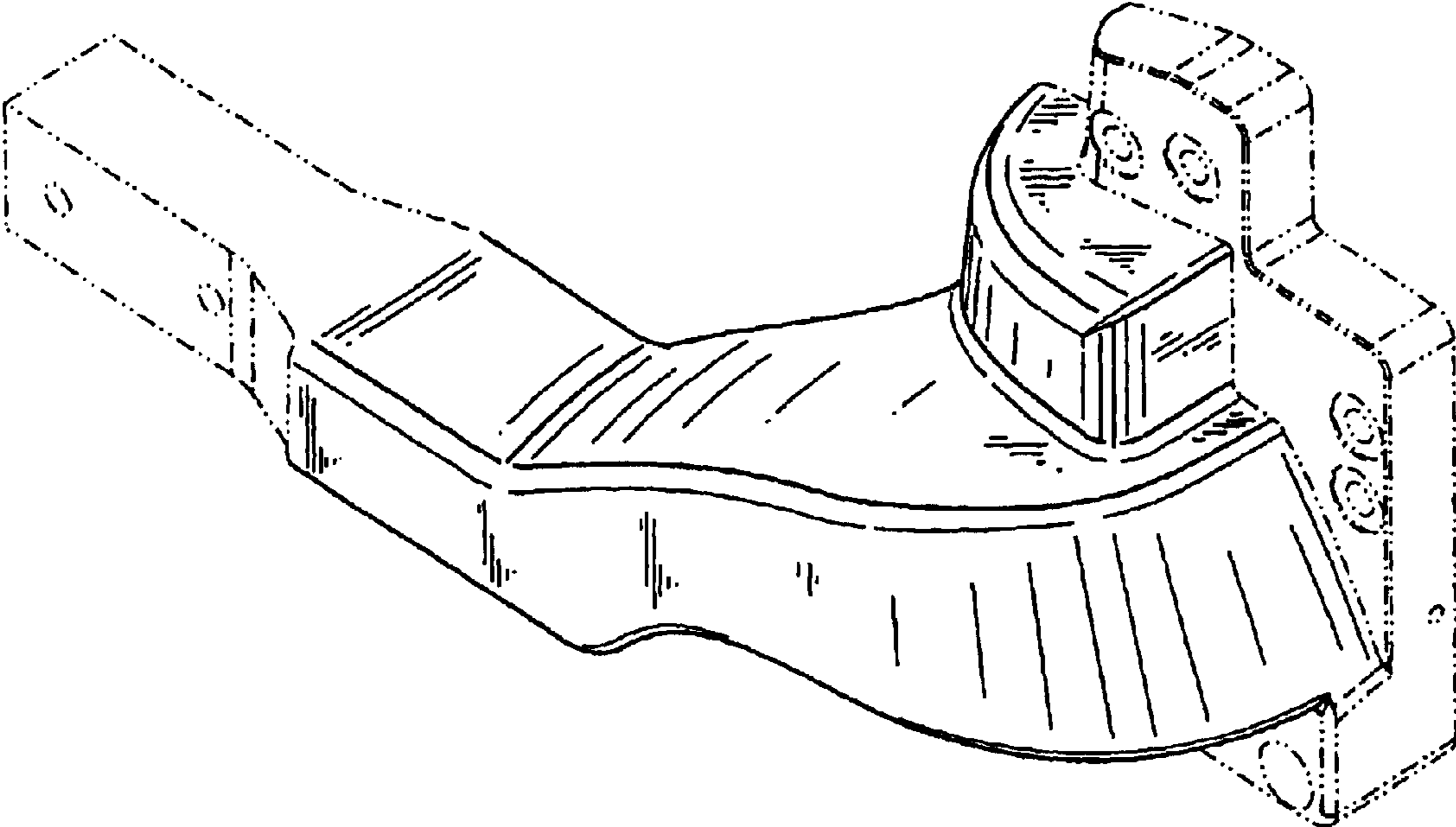

FIG. 28