



US00D499362S

(12) **United States Design Patent** (10) **Patent No.:** **US D499,362 S**  
**Minami et al.** (45) **Date of Patent:** **\*\* Dec. 7, 2004**

(54) **BUMPER FOR AN AUTOMOBILE**  
(75) Inventors: **Takahiro Minami**, Kanagawa-ken (JP);  
**Yoshimasa Ueno**, Kanagawa-ken (JP)  
(73) Assignee: **Toyota Jidosha Kabushiki Kaisha** (JP)  
(\*\*) Term: **14 Years**

2001 Mercedes-Benz A Class; Imported Cars Guide Book,  
2002; Oct. 24, 2001; p. 119.

\* cited by examiner

*Primary Examiner*—Melody N. Brown  
(74) *Attorney, Agent, or Firm*—Saidman DesignLaw Group

(21) Appl. No.: **29/177,918**  
(22) Filed: **Mar. 18, 2003**  
(51) **LOC (7) Cl.** ..... **12-16**  
(52) **U.S. Cl.** ..... **D12/169**  
(58) **Field of Search** ..... D12/169, 196,  
D12/190, 90-92, 171; 296/180.1, 180.2;  
293/102, 113, 115, 120

(57) **CLAIM**  
The ornamental design for a bumper for an automobile, as  
shown and described.

**DESCRIPTION**

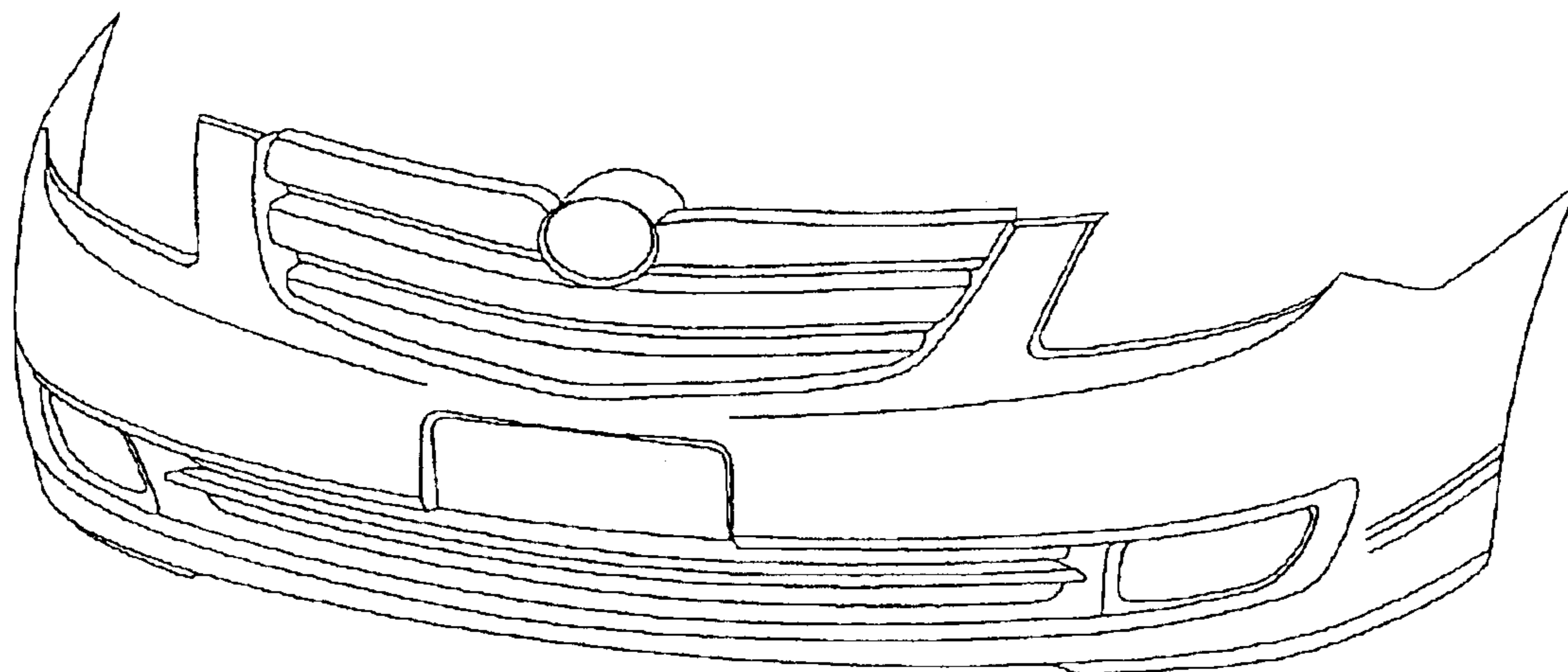
FIG. 1 is a perspective view of a bumper for an automobile  
showing our new design;  
FIG. 2 is a front view thereof;  
FIG. 3 is a rear view thereof;  
FIG. 4 is a top view thereof;  
FIG. 5 is a bottom view; and,  
FIG. 6 is a right side view thereof, the left side view being  
a mirror image.

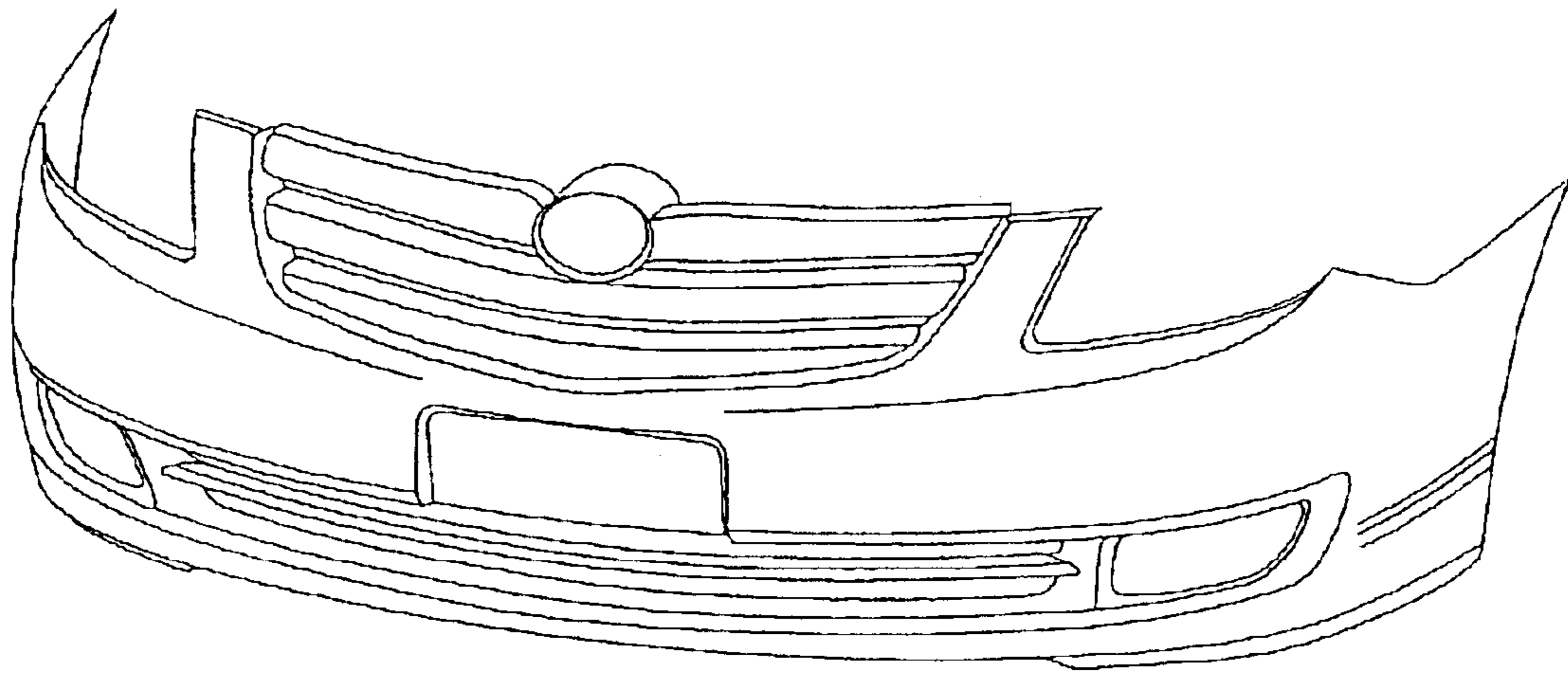
(56) **References Cited**  
**U.S. PATENT DOCUMENTS**  
D452,207 S \* 12/2001 Ishii et al. .... D12/169  
D472,856 S \* 4/2003 Oishi et al. .... D12/169  
D479,491 S \* 9/2003 Kato et al. .... D12/91  
D483,706 S \* 12/2003 Kato ..... D12/169

**OTHER PUBLICATIONS**

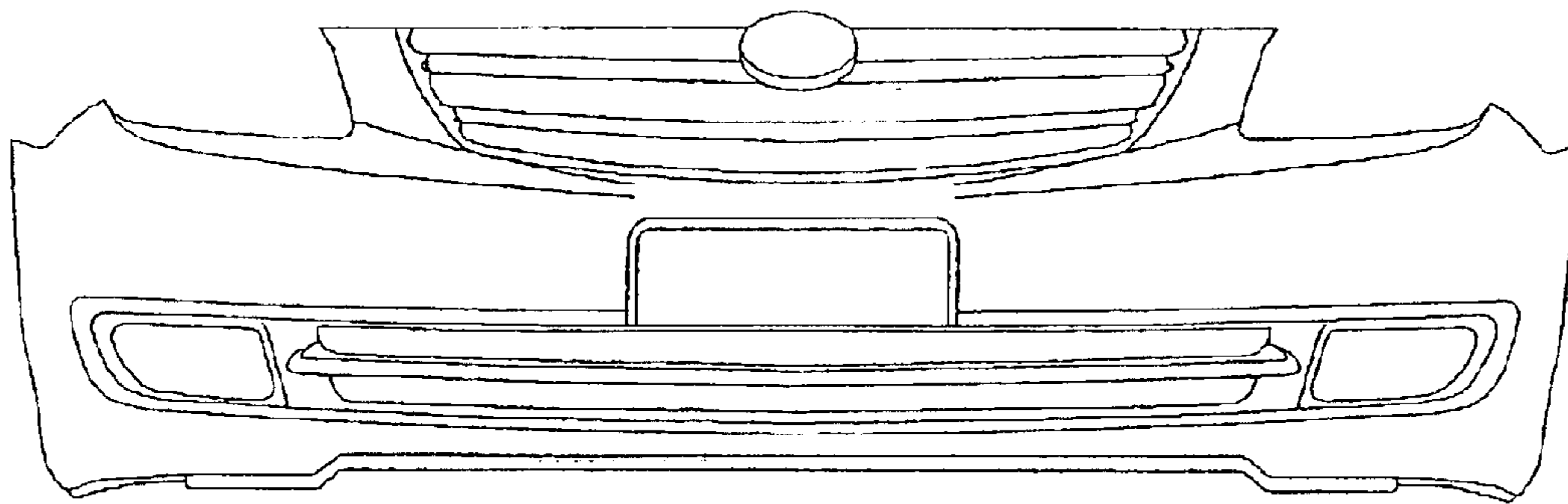
2002 Toyota IST; Brochure of IST; May 2002.  
2001 Honda Stream; Automotive Guidebook of Japan; Oct.  
24, 2001; p. 80.

**1 Claim, 4 Drawing Sheets**

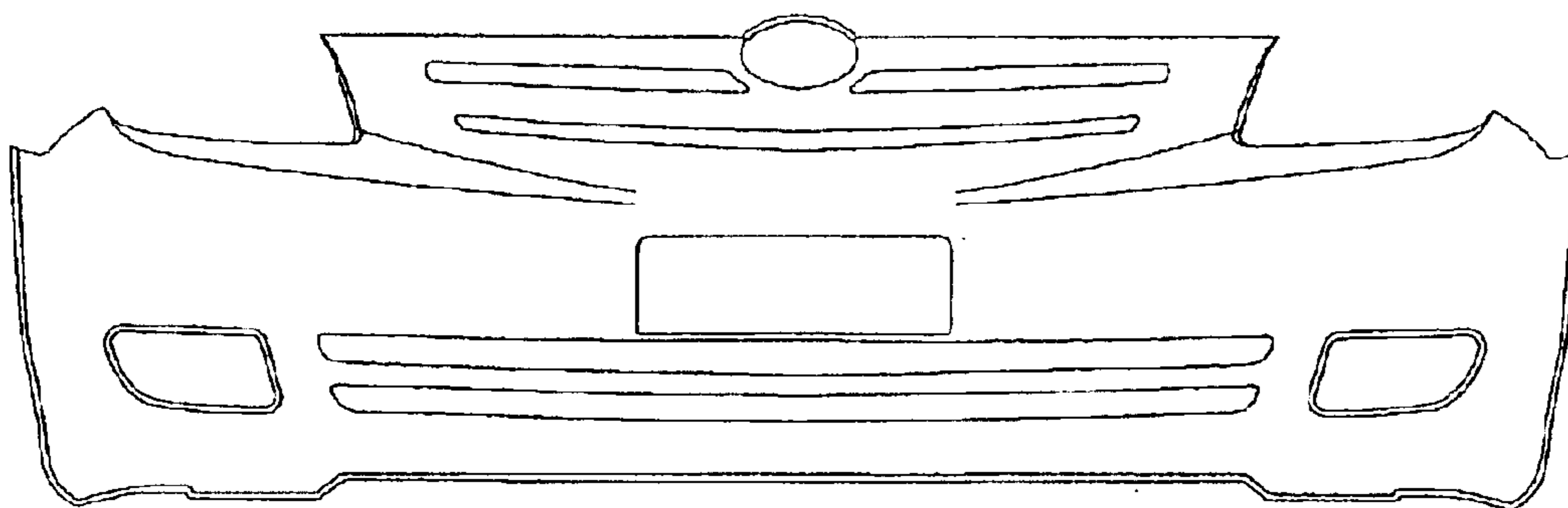




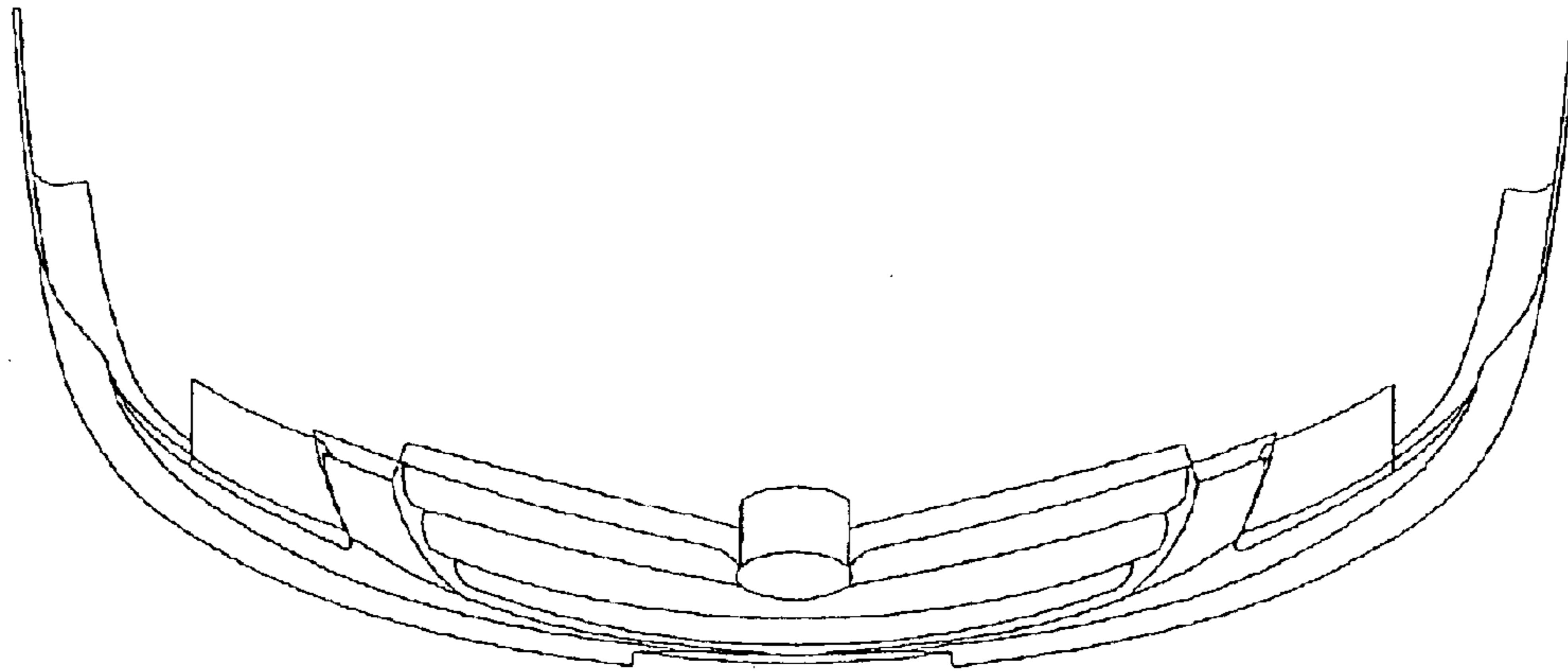
**FIG. 1**



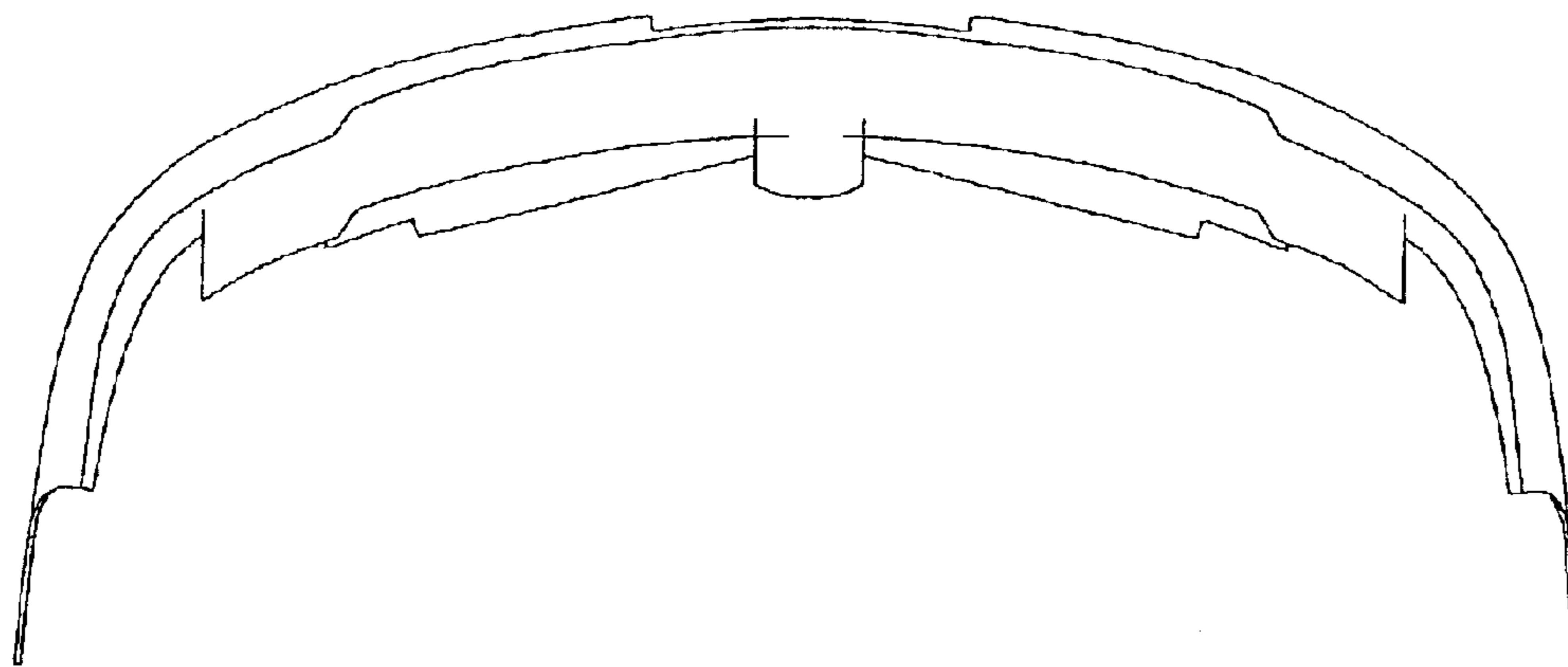
**FIG. 2**



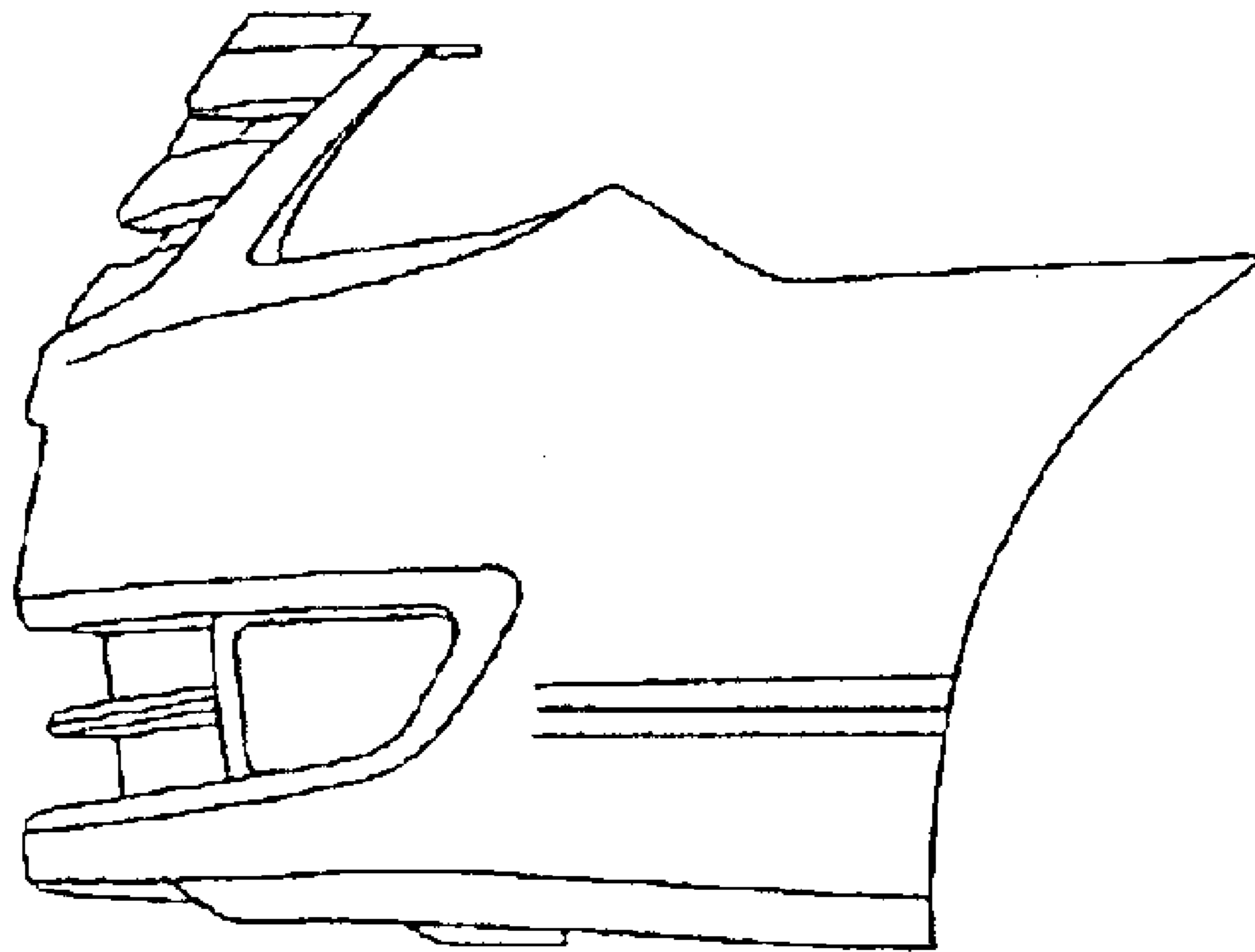
**FIG. 3**



**FIG. 4**



**FIG. 5**



**FIG. 6**