

US00D499051S

(12) **United States Design Patent** (10) **Patent No.:** **US D499,051 S**
Nakamura et al. (45) **Date of Patent:** **** Nov. 30, 2004**

(54) **AUTOMOBILE BUMPER**

(75) Inventors: **Machio Nakamura**, Aichi-ken (JP);
Kenji Kido, Aichi-ken (JP)

(73) Assignee: **Toyota Jidosha Kabushiki Kaisha**,
Aichi-ken (JP)

(**) Term: **14 Years**

(21) Appl. No.: **29/182,053**

(22) Filed: **May 20, 2003**

(51) **LOC (7) Cl.** **12-16**

(52) **U.S. Cl.** **D12/169**

(58) **Field of Search** D12/90-92, 86,
D12/169, 196; 296/180.1, 180.2; 293/102,
113, 115, 117, 120

(56) **References Cited**

U.S. PATENT DOCUMENTS

D462,640 S	*	9/2002	Sakae	D12/169
D473,167 S	*	4/2003	Shiono	D12/169
D473,168 S	*	4/2003	Hayashi	D12/169
D473,499 S	*	4/2003	Tanabe et al.	D12/169
D473,500 S	*	4/2003	Okumoto et al.	D12/169
D474,720 S	*	5/2003	Tachibana et al.	D12/169

OTHER PUBLICATIONS

Brochure of Celsior, "Celsior," (Mfg.—Toyota Jidosha Kabushiki Kaisha), Aug. 2001.

Brochure of Crown Athlete, "Crown Athlete," (Mfg.—Toyota Jidosha Kabushiki Kaisha), Aug. 20, 2001.

Imported Cars Guide Book 2001, Mercedes Benz S 600L, (Mfg. Mercedes-Benz), Nov. 17, 2000, p. 138.

* cited by examiner

Primary Examiner—Melody N. Brown

(74) *Attorney, Agent, or Firm*—Finnegan, Henderson, Farabow, Garrett & Dunner, L.L.P.

(57) **CLAIM**

The ornamental design for an automobile bumper, as shown and described.

DESCRIPTION

FIG. 1 is a left-front, perspective view of an automobile bumper of our new design;
 FIG. 2 is a front view of our new design;
 FIG. 3 is a rear view of our new design;
 FIG. 4 is a left-side view our new design, the right-side view being a mirror image thereof;
 FIG. 5 is a top view of our new design;
 FIG. 6 is a bottom view of our new design;
 FIG. 7 is a cross-sectional view of our new design taken along the line 7—7 in FIG. 2, showing the profile of that portion of the design;
 FIG. 8 is a cross-sectional view of our new design taken along the line 8—8 in FIG. 2, showing the profile of that portion of the design;
 FIG. 9 is a cross-sectional view of our new design taken along the line 9—9 in FIG. 2, showing the profile of that portion of the design; and,
 FIG. 10 is a cross-sectional view of our new design taken along the line 10—10 in FIG. 2, showing the profile of that portion of the design.

1 Claim, 5 Drawing Sheets

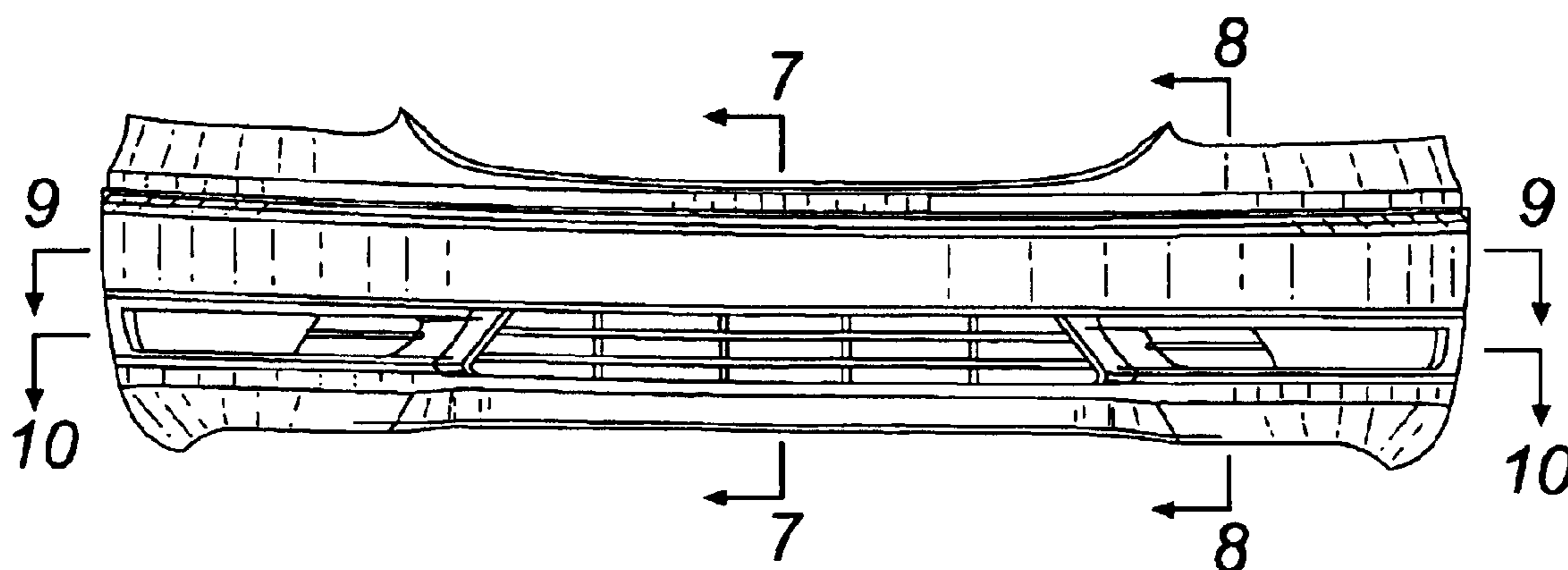

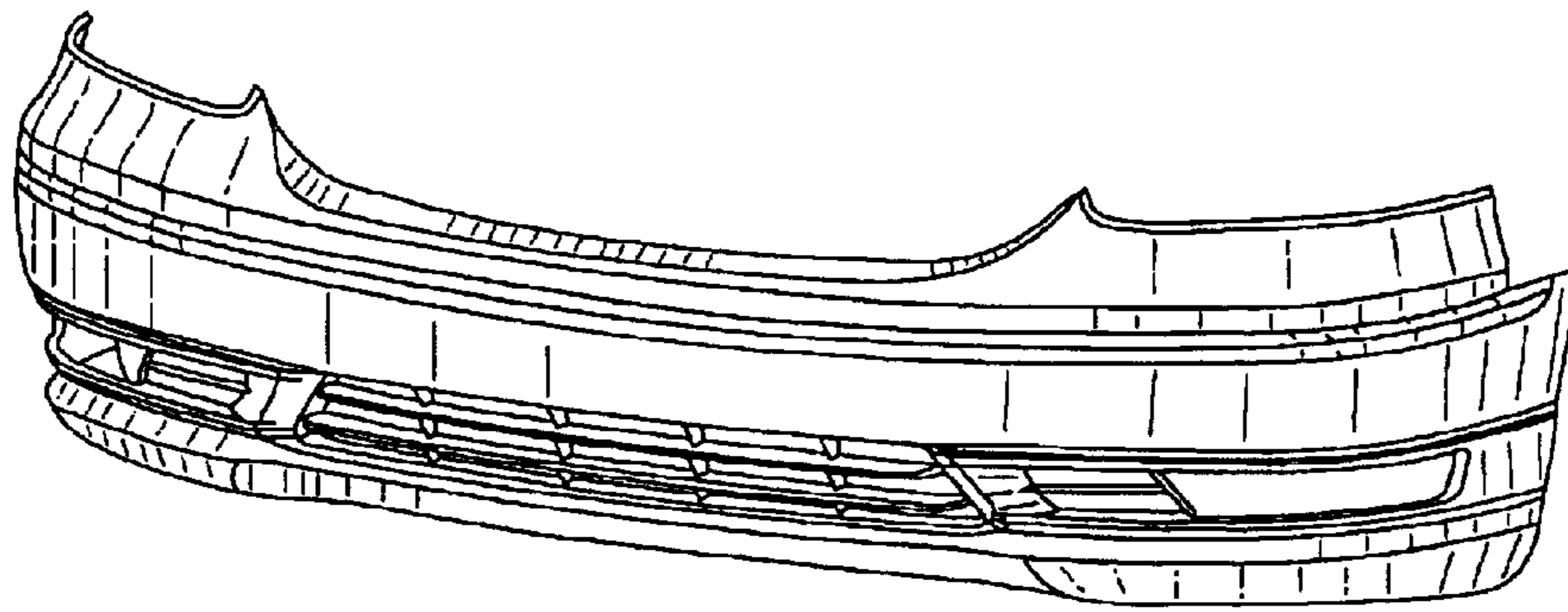

FIG. 1

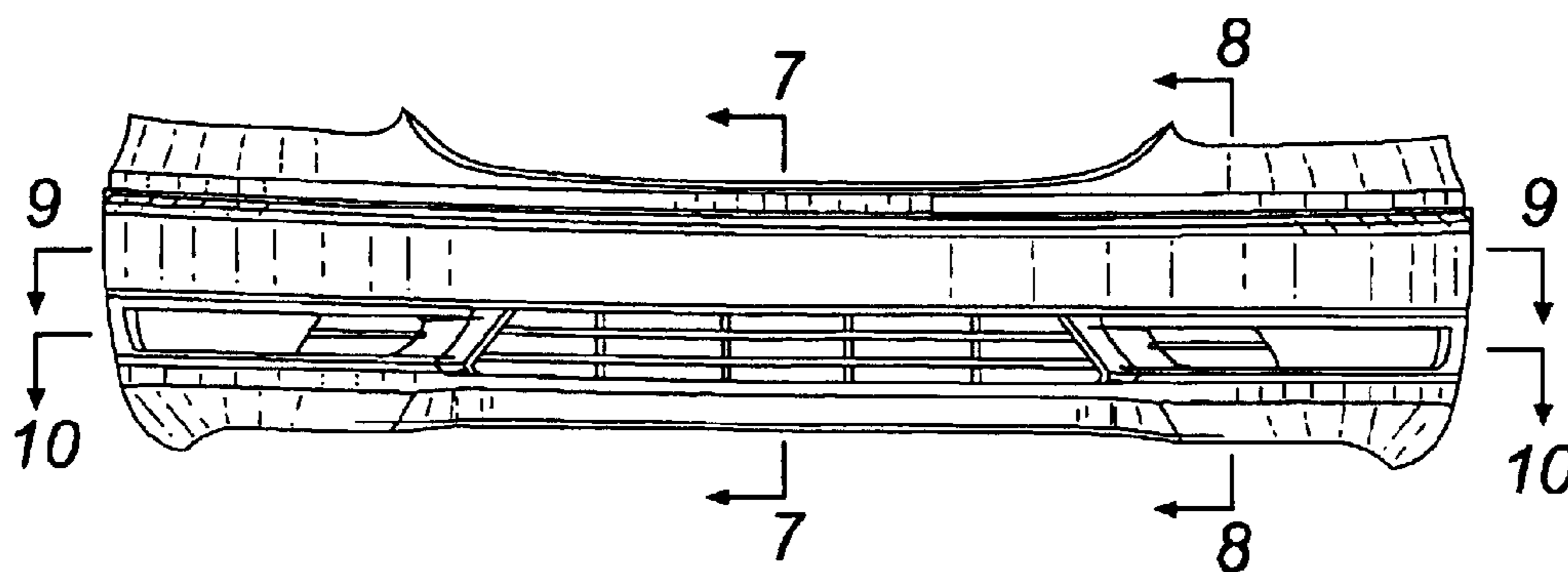

FIG. 2

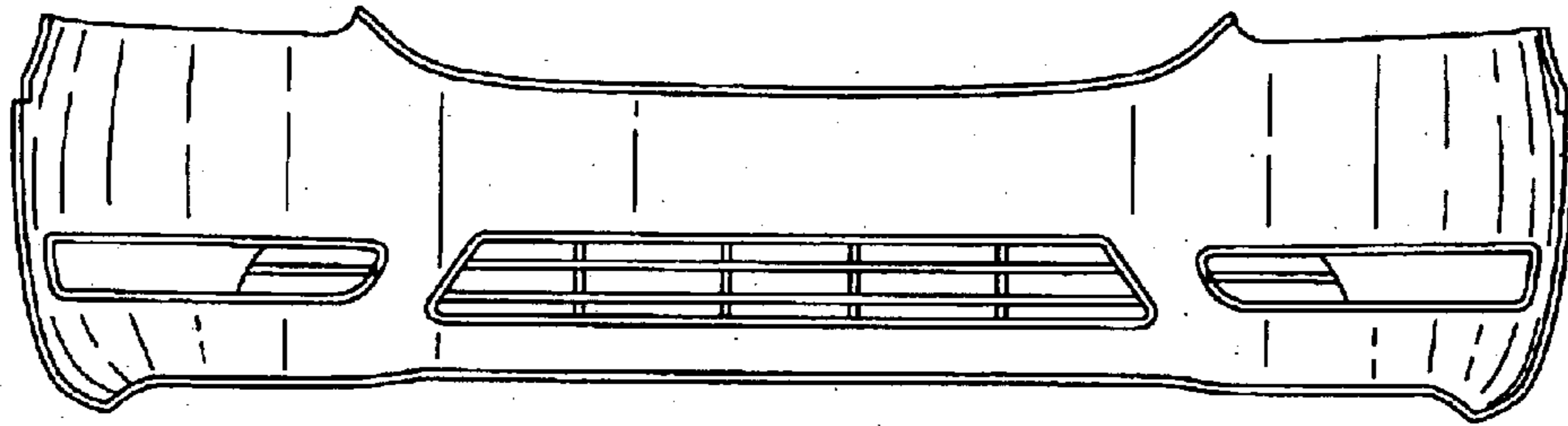

FIG. 3

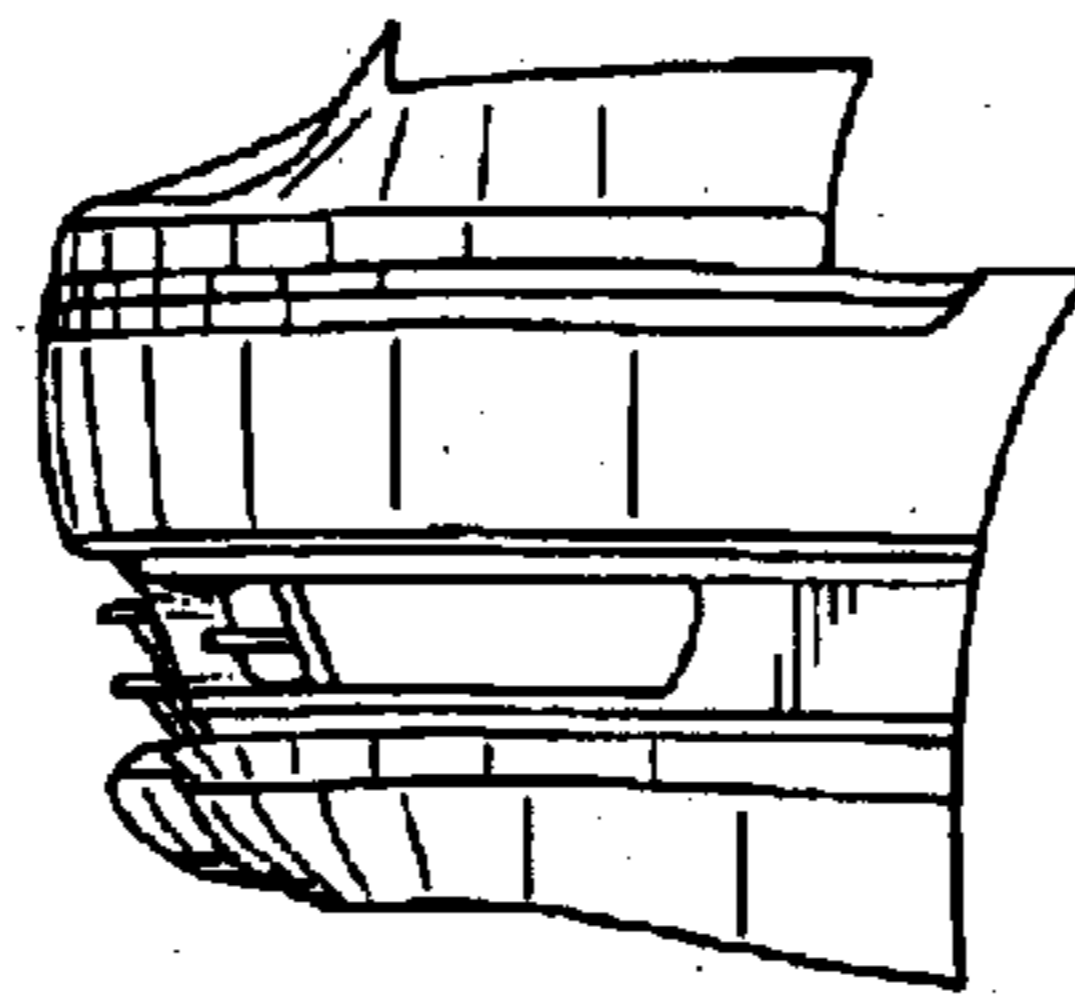

FIG. 4

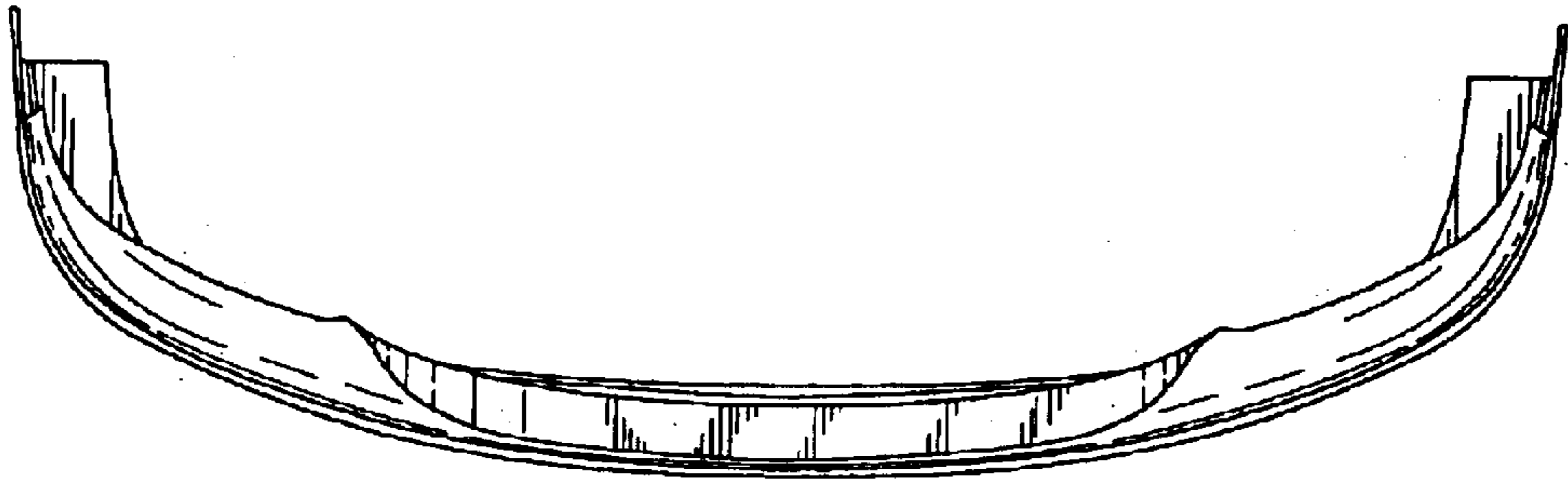

FIG. 5



FIG. 6



FIG. 7



FIG. 8

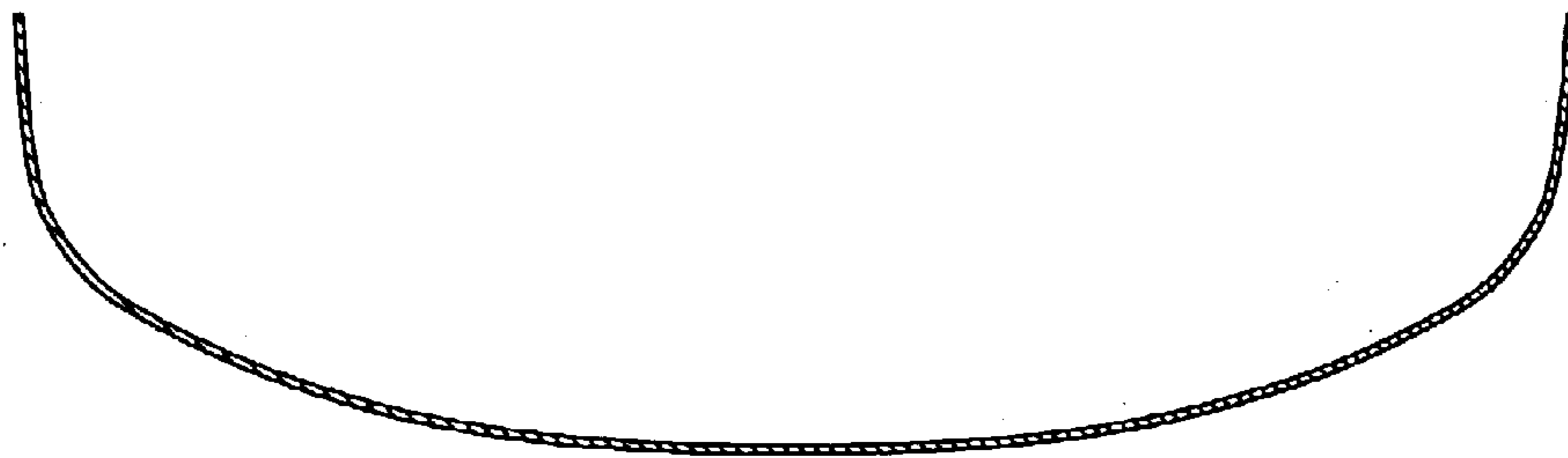

FIG. 9

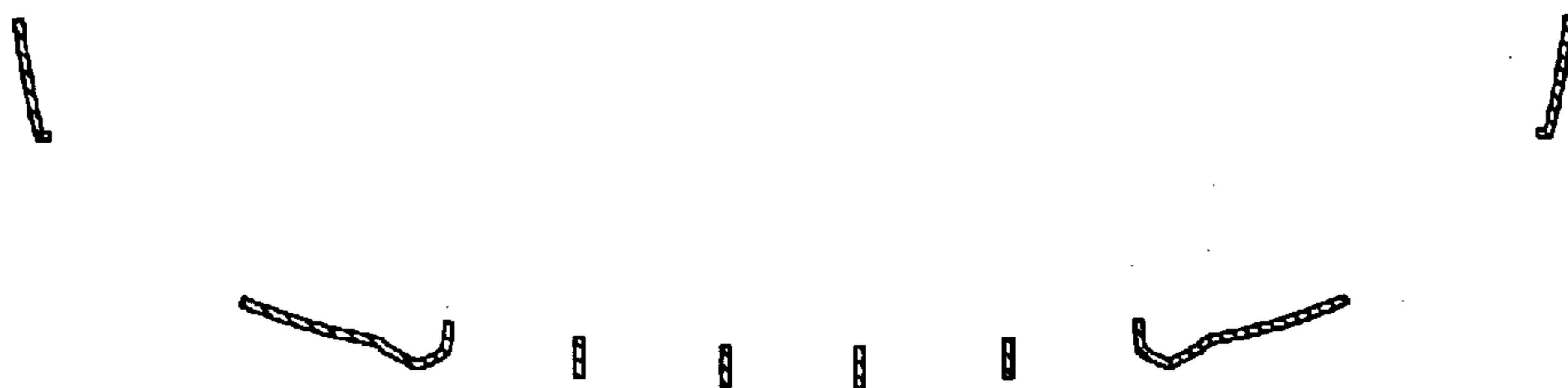

FIG. 10