

US00D499048S

(12) **United States Design Patent**
Tsukahara et al.

(10) **Patent No.:** **US D499,048 S**
(45) **Date of Patent:** **** Nov. 30, 2004**

(54) **AUTOMOBILE**

D490,019 S * 5/2004 Sakae D12/91

(75) Inventors: **Hijiri Tsukahara**, Shizuoka-ken (JP);
Kazuto Subashiri, Shizuoka-ken (JP)

FOREIGN PATENT DOCUMENTS

JP D1126503 11/2001
JP D1126832 11/2001

(73) Assignee: **Suzuki Motor Corporation**,
Shizuoka-ken (JP)

* cited by examiner

(**) Term: **14 Years**

Primary Examiner—Melody N. Brown
(74) *Attorney, Agent, or Firm*—Nixon & Vanderhye, P.C.

(21) Appl. No.: **29/195,314**

(57) **CLAIM**

(22) Filed: **Dec. 10, 2003**

The ornamental design for an automobile, as shown and described.

(30) **Foreign Application Priority Data**

DESCRIPTION

Jun. 10, 2003 (JP) 2003-016367

(51) **LOC (7) Cl.** **12-08**

FIG. 1 is a front elevational view of an automobile showing our new design;

(52) **U.S. Cl.** **D12/91**

FIG. 2 is a rear elevational view thereof;

(58) **Field of Search** D12/90-92, 86,
D12/88; D21/424, 433, 548, 549; 296/185,
186

FIG. 3 is a top plan view thereof;

FIG. 4 is a bottom plan view thereof;

FIG. 5 is a right side elevational view thereof;

FIG. 6 is a left side elevational view thereof;

FIG. 7 is a top, front, and right side perspective view thereof;

and,

FIG. 8 is a top, rear, and right side perspective view thereof.

(56) **References Cited**

U.S. PATENT DOCUMENTS

D402,319 S * 12/1998 Fu D12/91
D458,871 S * 6/2002 Honda et al. D12/92
D488,743 S * 4/2004 Takagi et al. D12/91

1 Claim, 7 Drawing Sheets

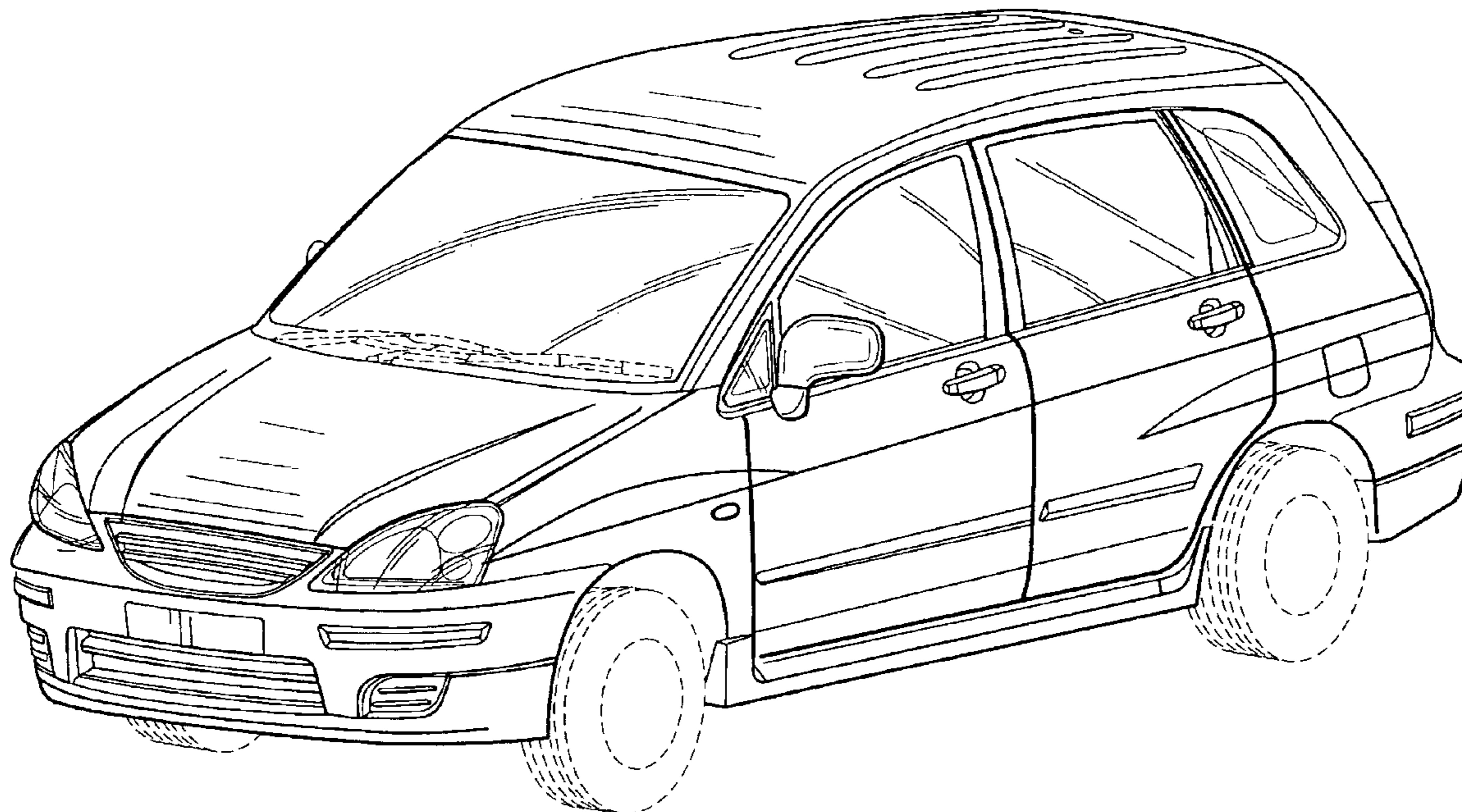

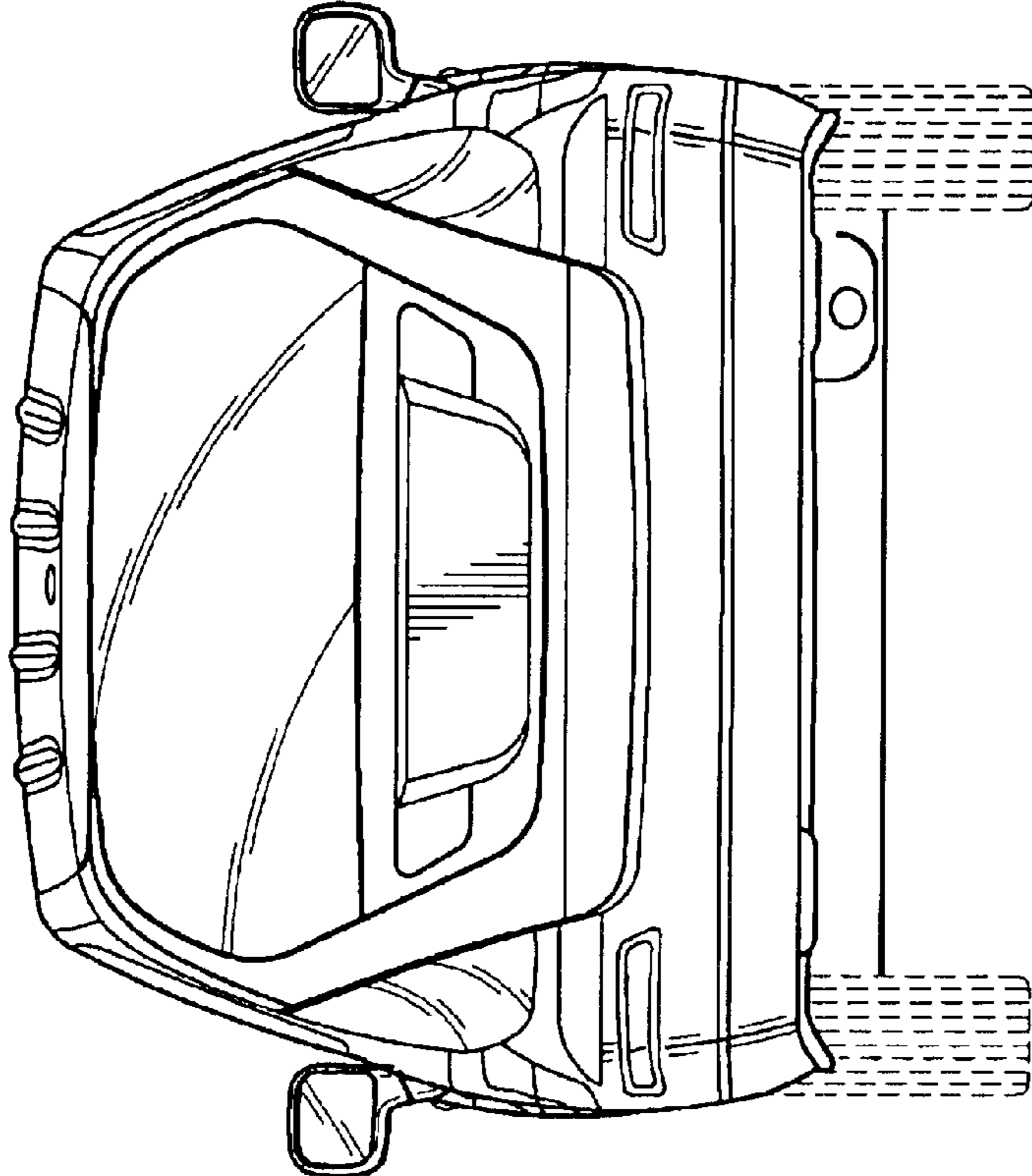

Fig. 2

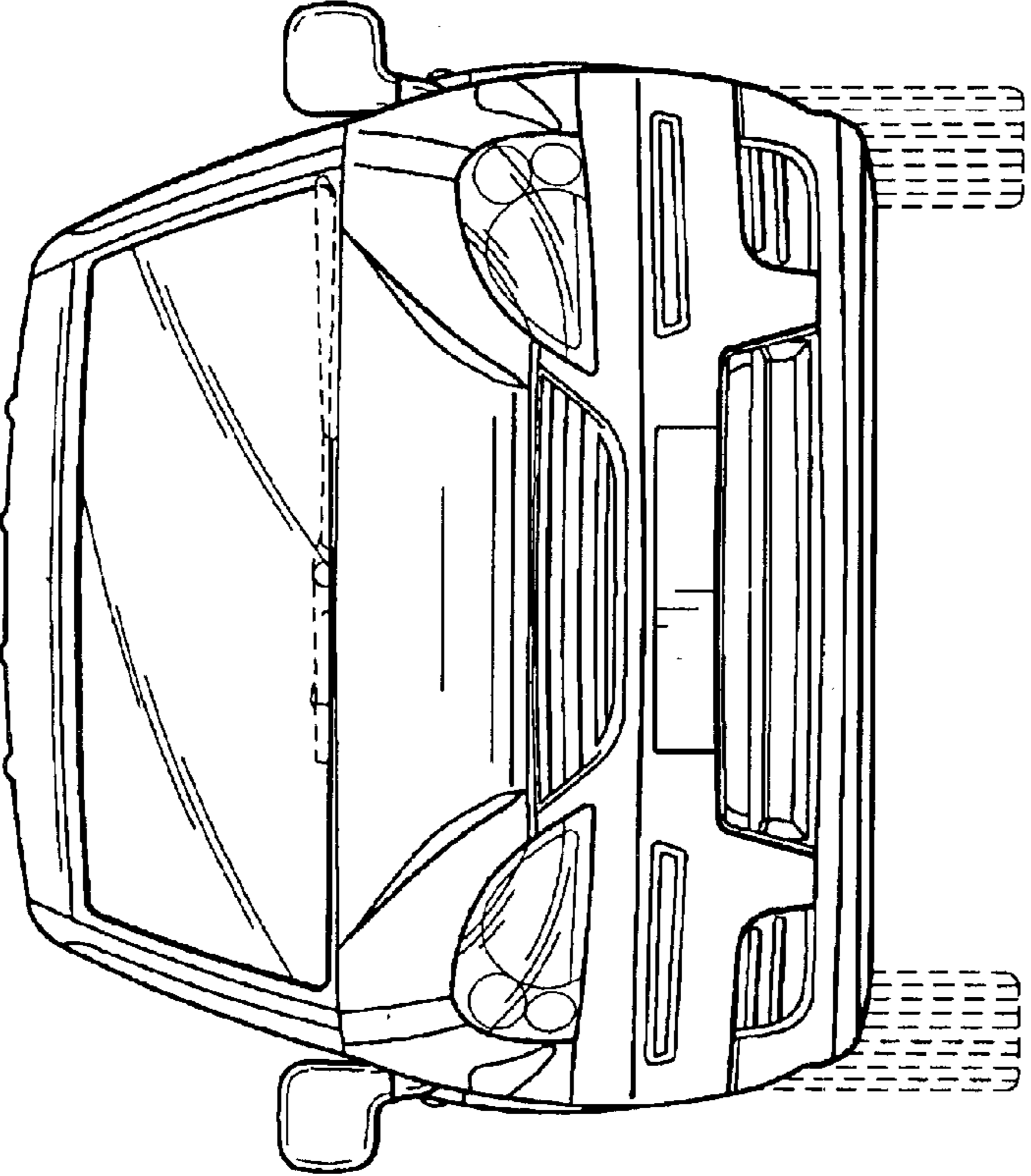

Fig. 1

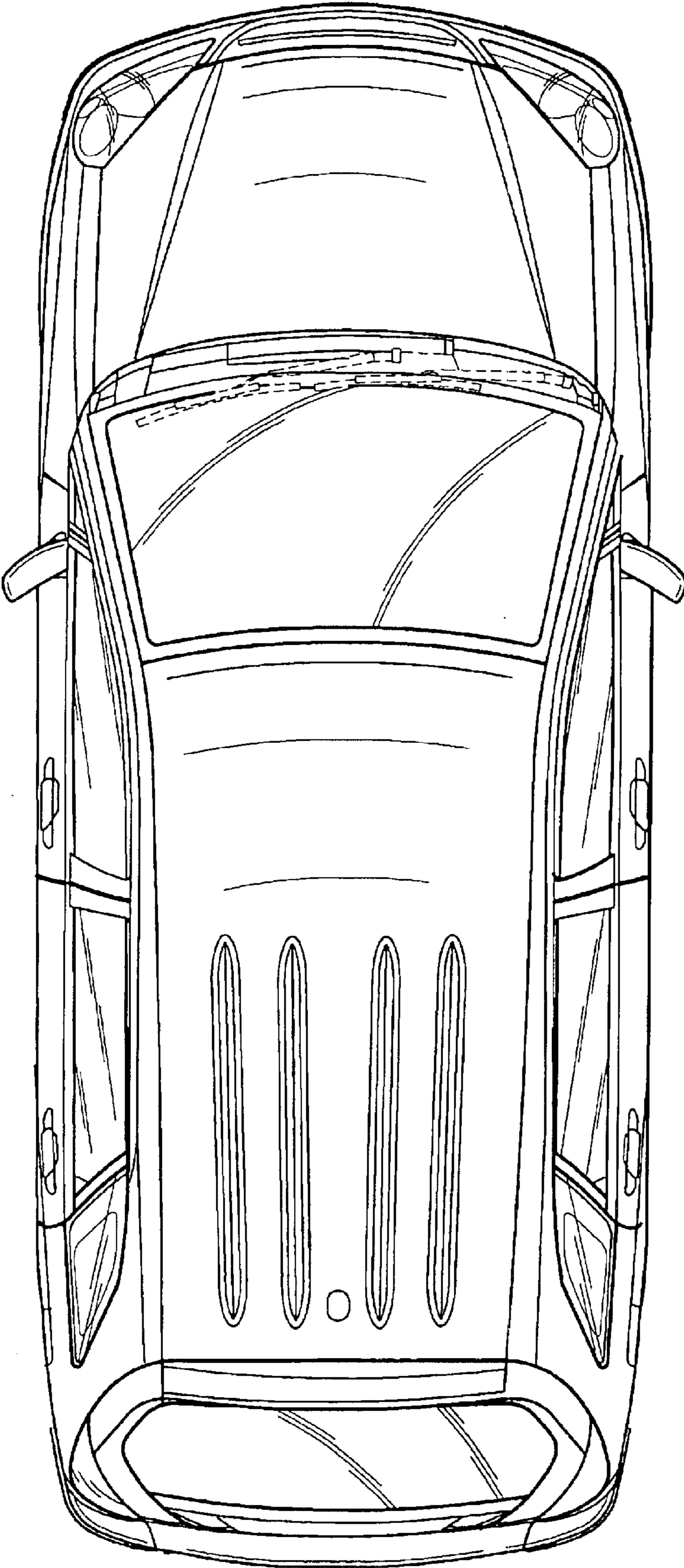

Fig. 3

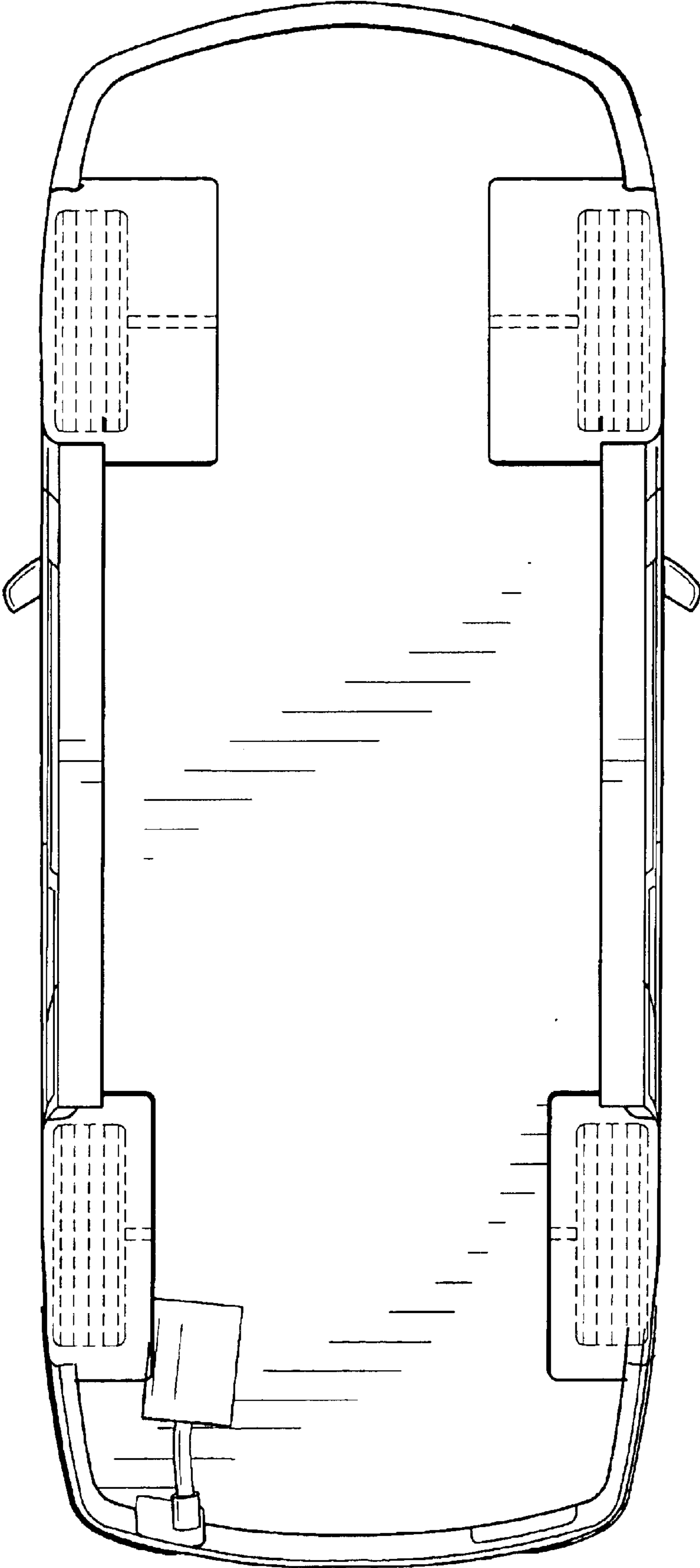

Fig. 4

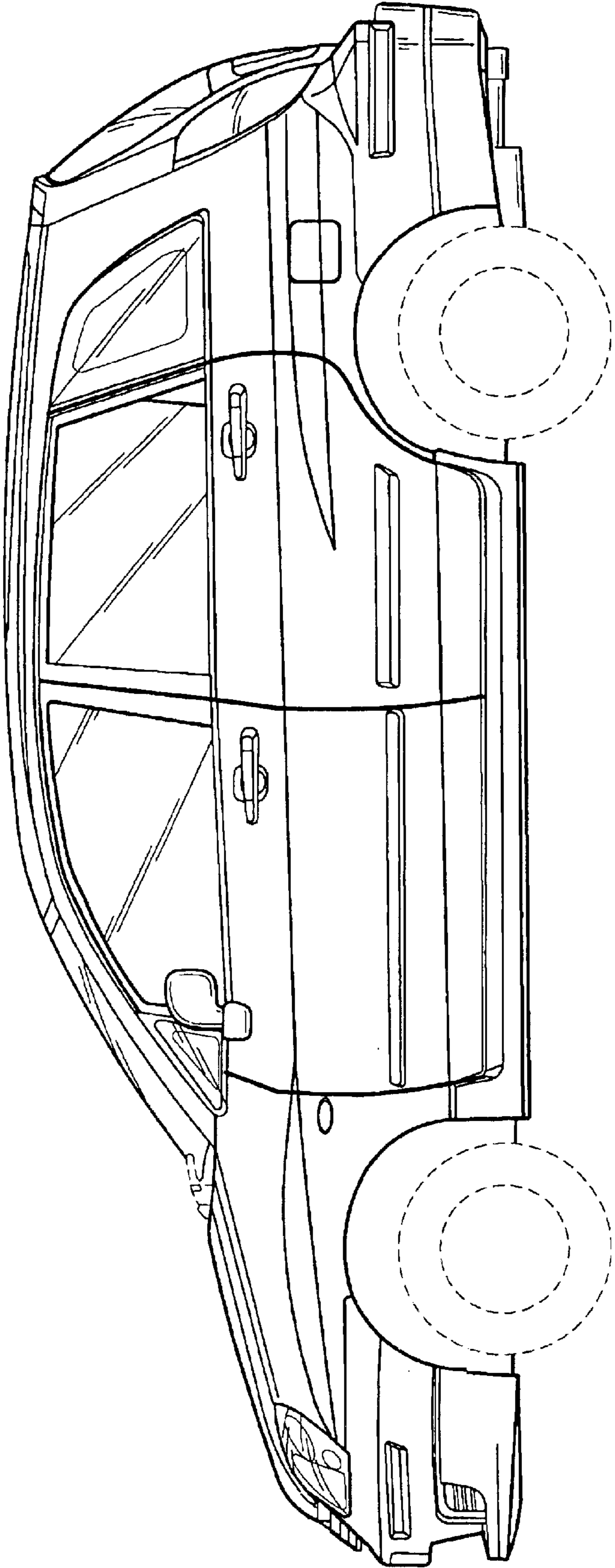

Fig. 5

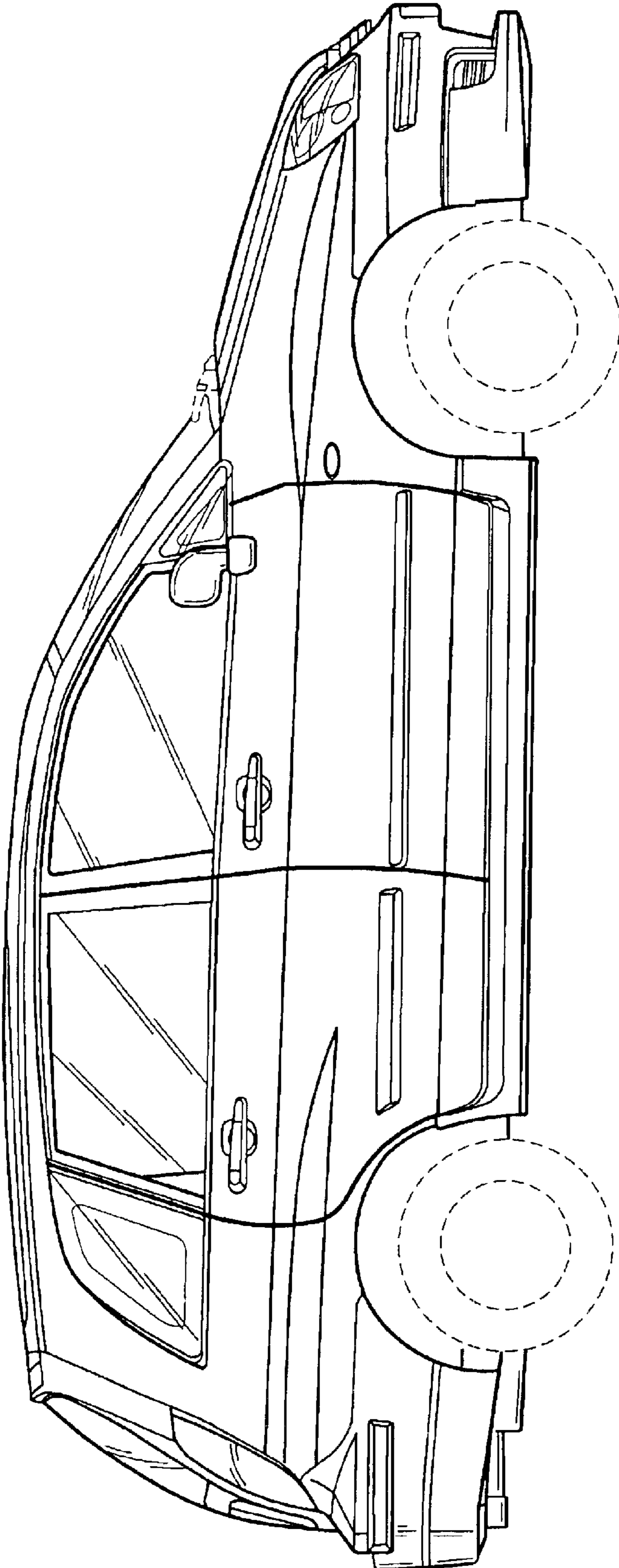

Fig. 6

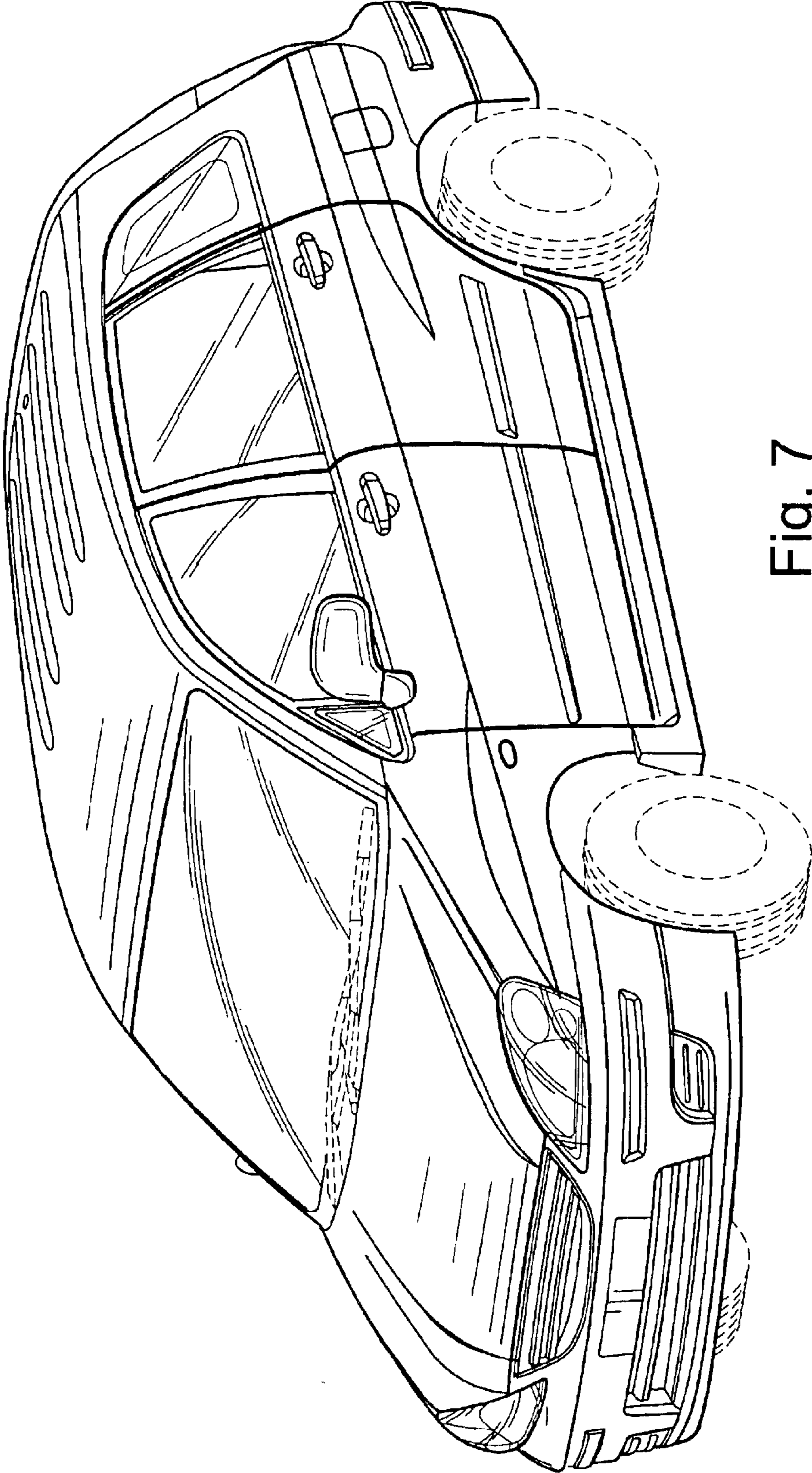

Fig. 7

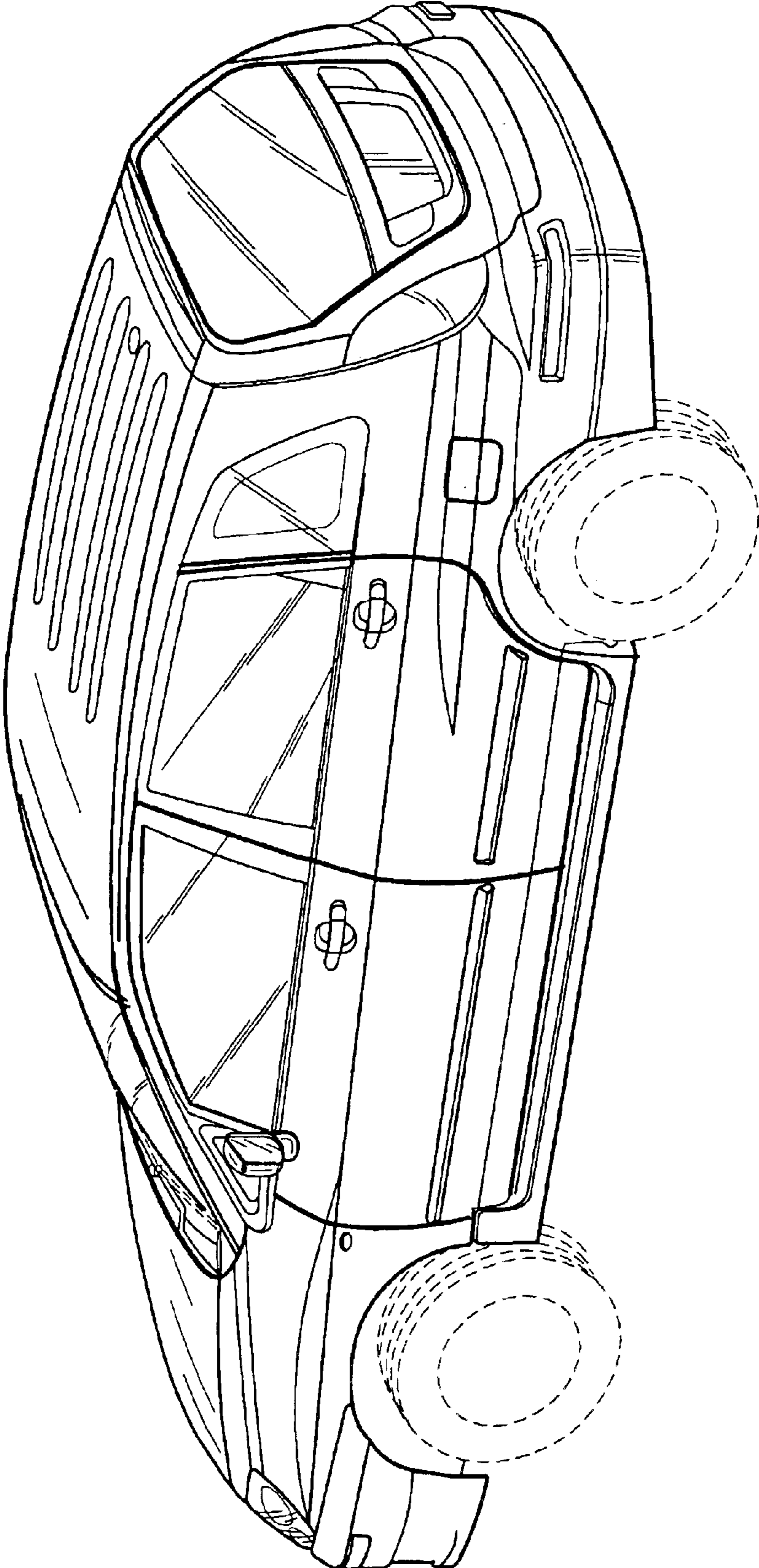

Fig. 8