

US00D498776S

(12) **United States Design Patent** (10) **Patent No.:** **US D498,776 S**
Hu (45) **Date of Patent:** **** Nov. 23, 2004**

(54) **GEAR WHEEL**

(76) Inventor: **Bobby Hu**, 8F, No. 536-1, Ta Chin Street, Taichung (TW)

(**) Term: **14 Years**

(21) Appl. No.: **29/203,961**

(22) Filed: **Apr. 22, 2004**

(51) **LOC (7) Cl.** **15-09**

(52) **U.S. Cl.** **D15/148**

(58) **Field of Search** D15/148-149;
474/152, 162; 81/60, 63, 63.2

2002/0023520 A1 * 2/2002 Hu 81/63.2
 2003/0115993 A1 * 6/2003 Chang 81/60
 2003/0230174 A1 * 12/2003 Hsien 81/60
 2004/0011162 A1 * 1/2004 Hsien 81/63.2
 2004/0055422 A1 * 3/2004 Lin 81/60

* cited by examiner

Primary Examiner—Antoine D. Davis

(74) *Attorney, Agent, or Firm*—Alan D. Kamrath; Nikolai & Mersereau, P.A.

(57) **CLAIM**

The ornamental design for gear wheel, as shown and described.

DESCRIPTION

FIG. 1 is a perspective view of a gear wheel showing my new design;

FIG. 2 is a front view thereof; the opposite side being a mirror image of the shown; and,

FIG. 3 is a top view thereof.

(56) **References Cited**

U.S. PATENT DOCUMENTS

D118,168 S * 12/1939 Nassimbene D15/148
 D392,656 S * 3/1998 Mizukami D15/149
 6,148,695 A * 11/2000 Hu 81/60
 6,282,991 B1 * 9/2001 Hu 81/63.2
 2002/0002092 A1 * 1/2002 Reguzzi 474/152
 2002/0023519 A1 * 2/2002 Hu 81/63.2

1 Claim, 2 Drawing Sheets

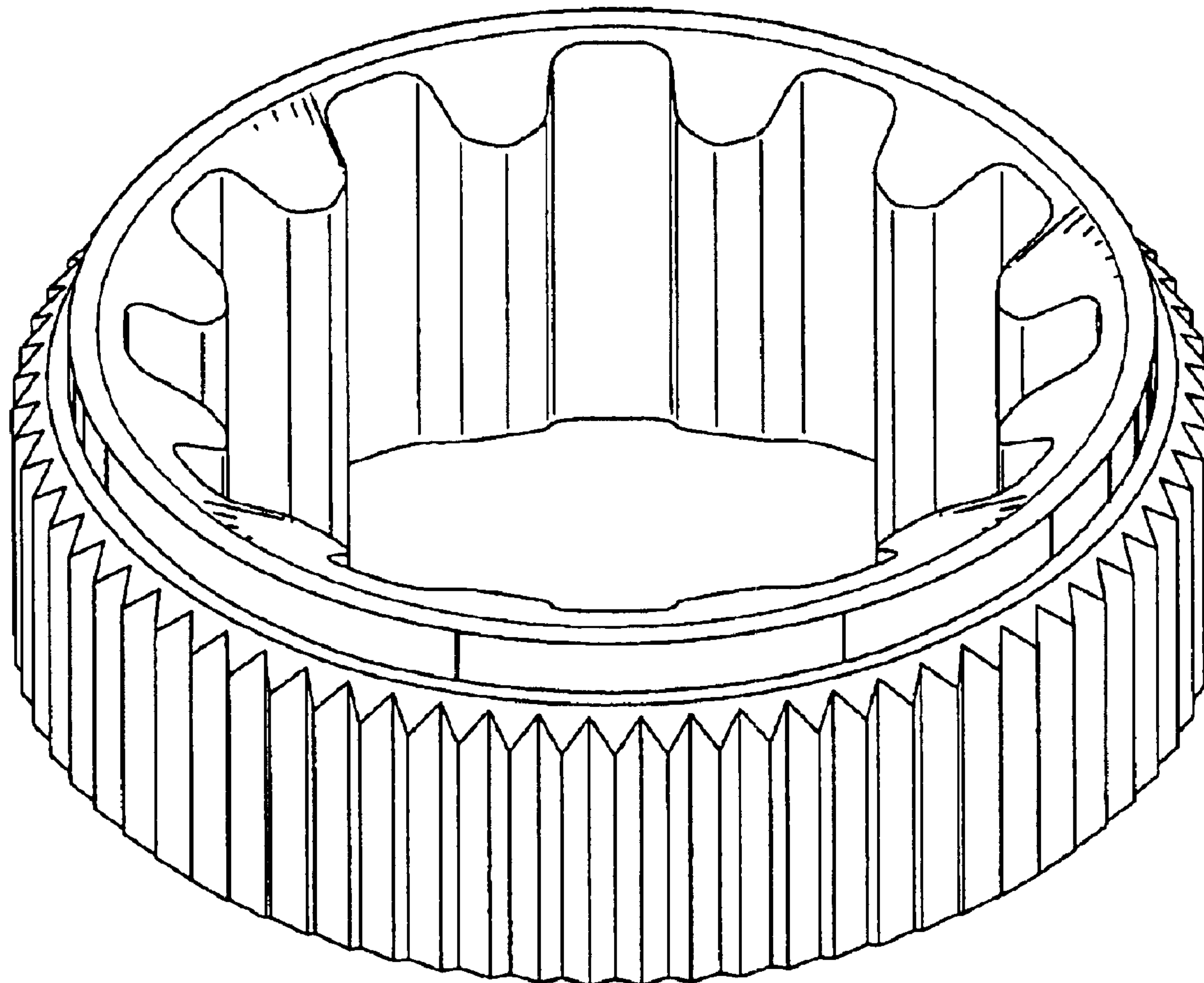

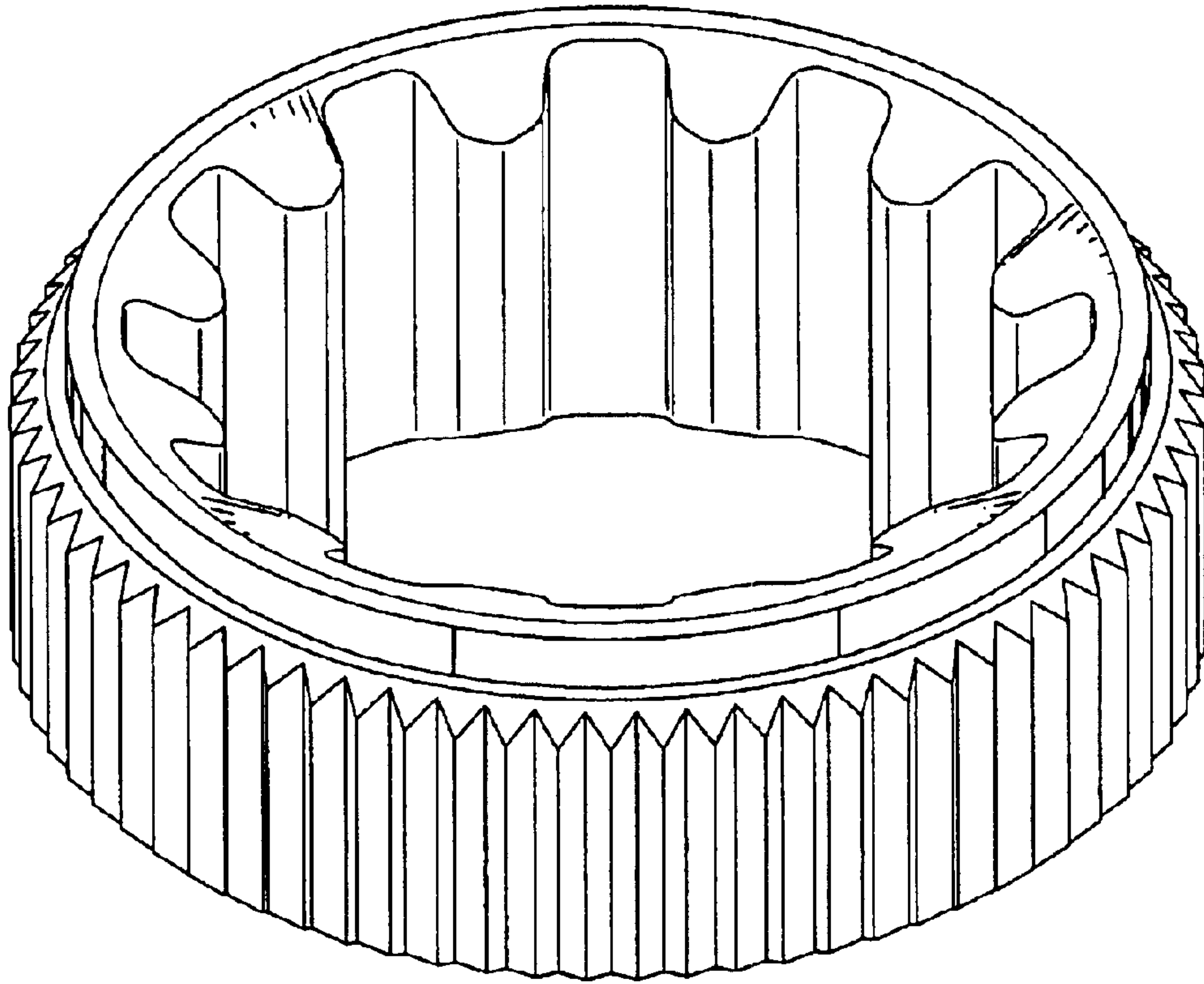

Fig. 1

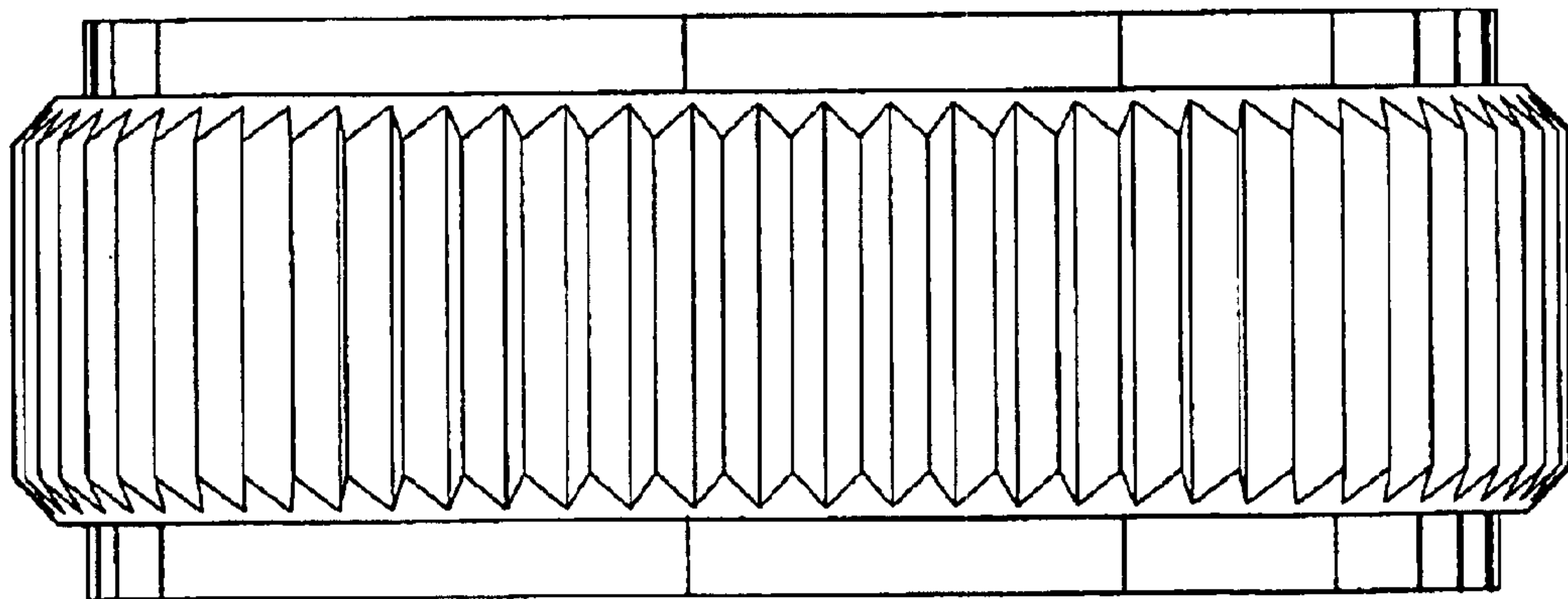

Fig. 2

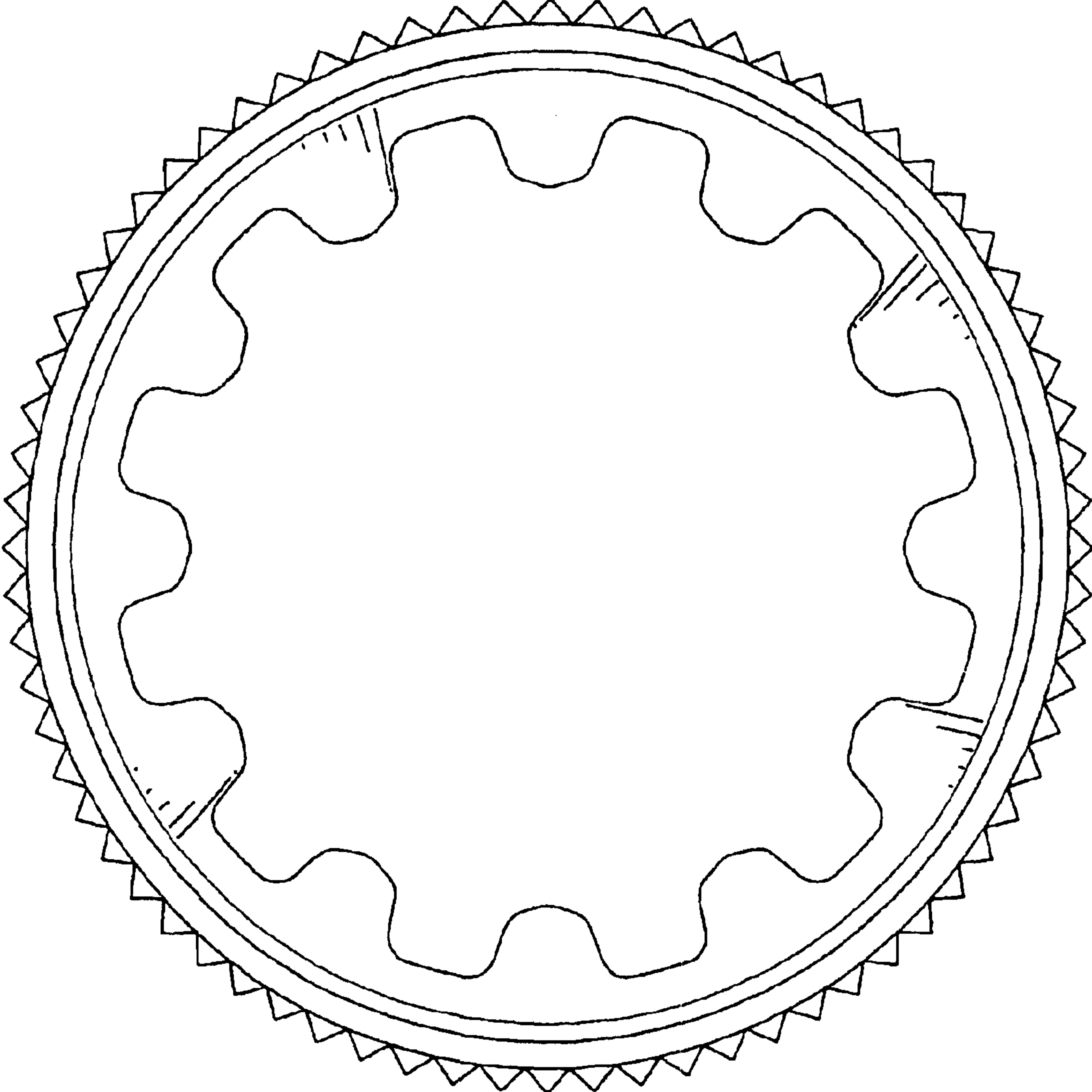

Fig. 3



US00D498776C1

(12) **EX PARTE REEXAMINATION CERTIFICATE** (6223rd)
United States Patent
Hu

(10) **Number:** **US D498,776 C1**
(45) **Certificate Issued:** **May 6, 2008**

(54) **GEAR WHEEL**

(56) **References Cited**

(76) **Inventor:** **Bobby Hu**, 8F, No. 536-1, Ta Chin Street, Taichung (TW)

U.S. PATENT DOCUMENTS

Reexamination Request:

No. 90/007,513, Apr. 22, 2005

4,991,468 A	*	2/1991	Lee	81/60
6,216,563 B1	*	4/2001	Hsieh	81/63.2
6,488,136 B2	*	12/2002	Chang	81/60
6,516,930 B2	*	2/2003	Chen	192/43.2
2003/0070512 A1	*	4/2003	Hu	81/63.2

Reexamination Certificate for:

Patent No.: **Des. 498,776**
Issued: **Nov. 23, 2004**
Appl. No.: **29/203,961**
Filed: **Apr. 22, 2004**

FOREIGN PATENT DOCUMENTS

TW	507637	*	10/2002
TW	571873	*	1/2004

- (51) **LOC (8) Cl.** **15-09**
- (52) **U.S. Cl.** **D15/148**
- (58) **Field of Classification Search** 81/60,
81/61, 62, 63, 63.1, 63.2; 192/46
See application file for complete search history.

* cited by examiner

Primary Examiner—Adir Aronovich

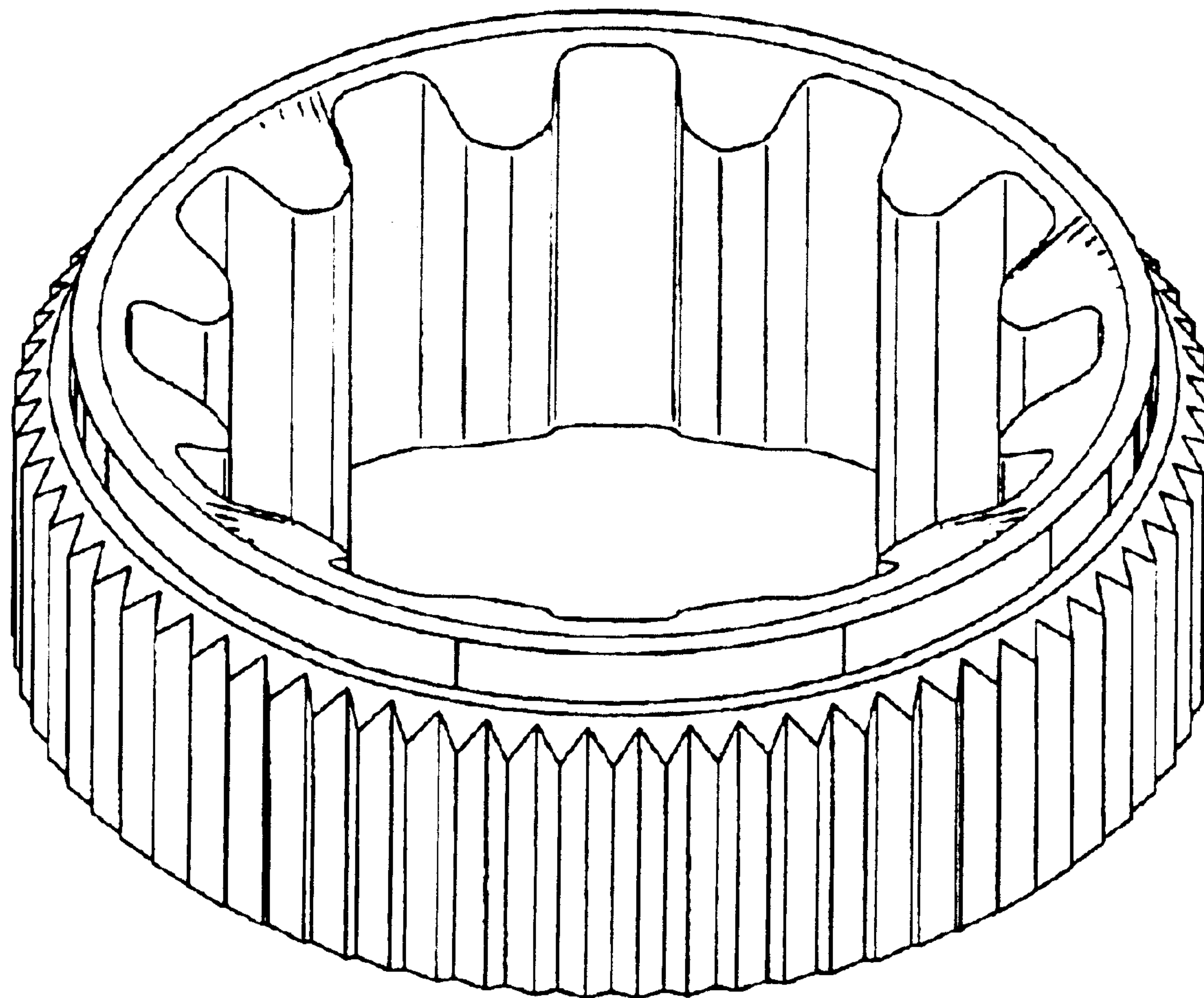

**EX PARTE
REEXAMINATION CERTIFICATE
ISSUED UNDER 35 U.S.C. 307**

Claim 1 is cancelled.

5 [The ornamental design for gear wheel, as shown and described.]

AS A RESULT OF REEXAMINATION, IT HAS BEEN DETERMINED THAT:

* * * * *