

US00D498655S

(12) **United States Design Patent** (10) **Patent No.:** **US D498,655 S**
Perfetti et al. (45) **Date of Patent:** **** Nov. 23, 2004**

(54) **HANDLE FOR AN OVER THE HIGHWAY TRUCK**

(75) Inventors: **Ruben Perfetti**, Greensboro, NC (US);
John Martin, Madison, NC (US);
Michael Sorrells, Greensboro, NC (US)

(73) Assignee: **Volvo Trucks North America, Inc.**,
Greensboro, NC (US)

(**) Term: **14 Years**

(21) Appl. No.: **29/186,475**

(22) Filed: **Jul. 16, 2003**

(51) **LOC (7) Cl.** **08-06**

(52) **U.S. Cl.** **D8/306**

(58) **Field of Search** D8/301, 306, 338,
D8/350, 353, 302, 307, 341, 321, 331;
70/135, 208; 292/336.3; D12/196

(56) **References Cited**

U.S. PATENT DOCUMENTS

D218,672 S	*	9/1970	Laufer	D8/302
D303,617 S	*	9/1989	Russell et al.	D8/306
D303,618 S	*	9/1989	Russell et al.	D8/306
D383,664 S	*	9/1997	Bennett	D8/331
D390,086 S	*	2/1998	Weinerman et al.	D8/306
D394,373 S	*	5/1998	Weinerman et al.	D8/306
D460,680 S	*	7/2002	Weinerman et al.	D8/353

OTHER PUBLICATIONS

1 page section of a story board used by the inventors of the present application depicting competing trucks that were on the market when this design was completed 1990.

* cited by examiner

Primary Examiner—Paula A. Greene

(74) *Attorney, Agent, or Firm*—Watts Hoffmann Co.

(57) **CLAIM**

We claim the ornamental design for a handle for an over the highway truck, as shown and described.

DESCRIPTION

FIG. 1 is a perspective view of the fairing handle of our new design;

FIG. 2 is a perspective view of the fairing handle;

FIG. 3 is a top plan view of the fairing handle;

FIG. 4 is a front elevational view of the fairing handle;

FIG. 5 is a right side elevational view of the fairing trim piece;

FIG. 6 is a rear elevational view of the fairing handle;

FIG. 7 is a left side elevational view of the fairing handle; and,

FIG. 8 is a bottom plan view of the fairing handle.

The broken lines shown are for illustrative purposes only and form no part of the claimed design.

1 Claim, 3 Drawing Sheets

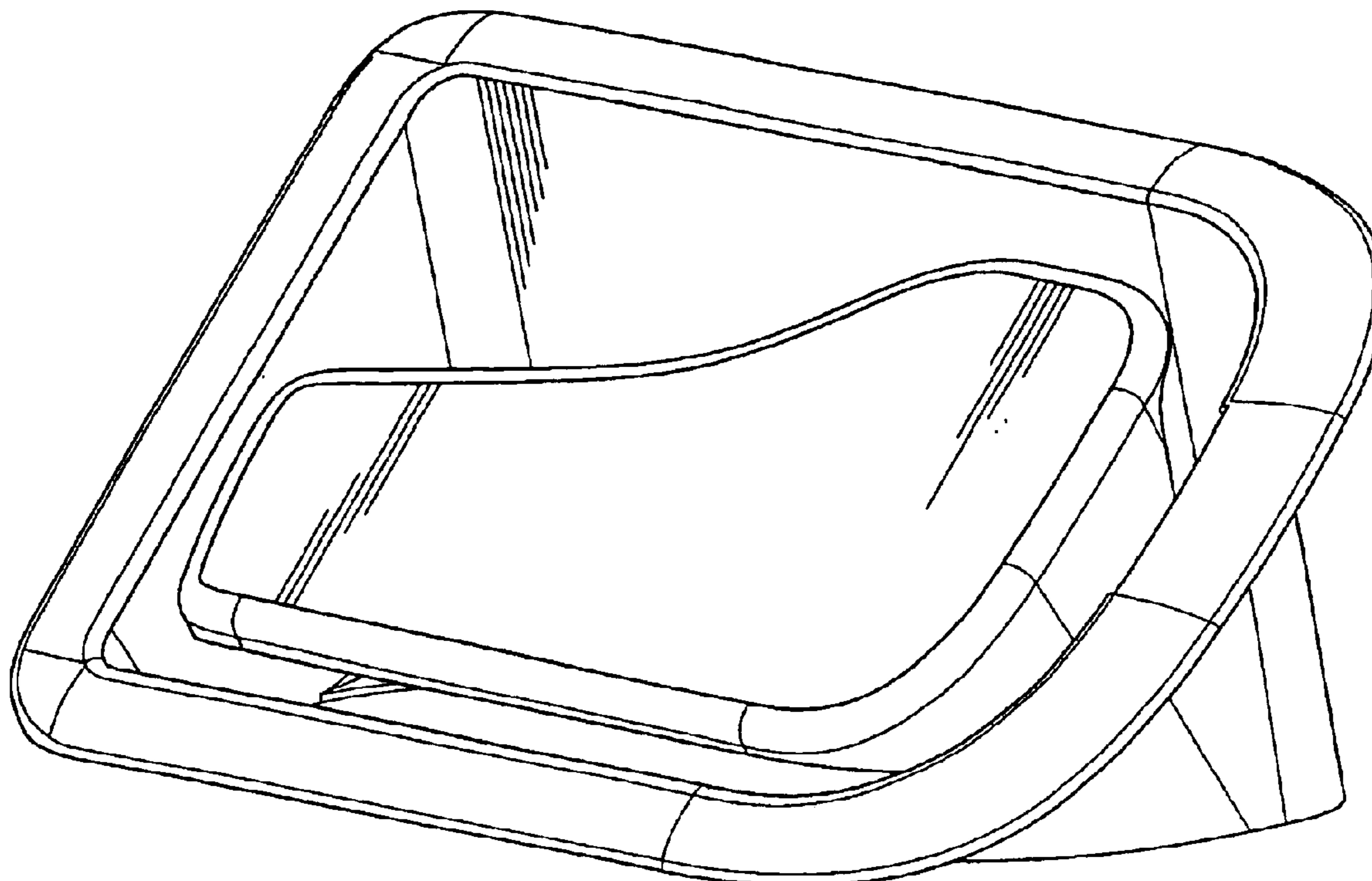

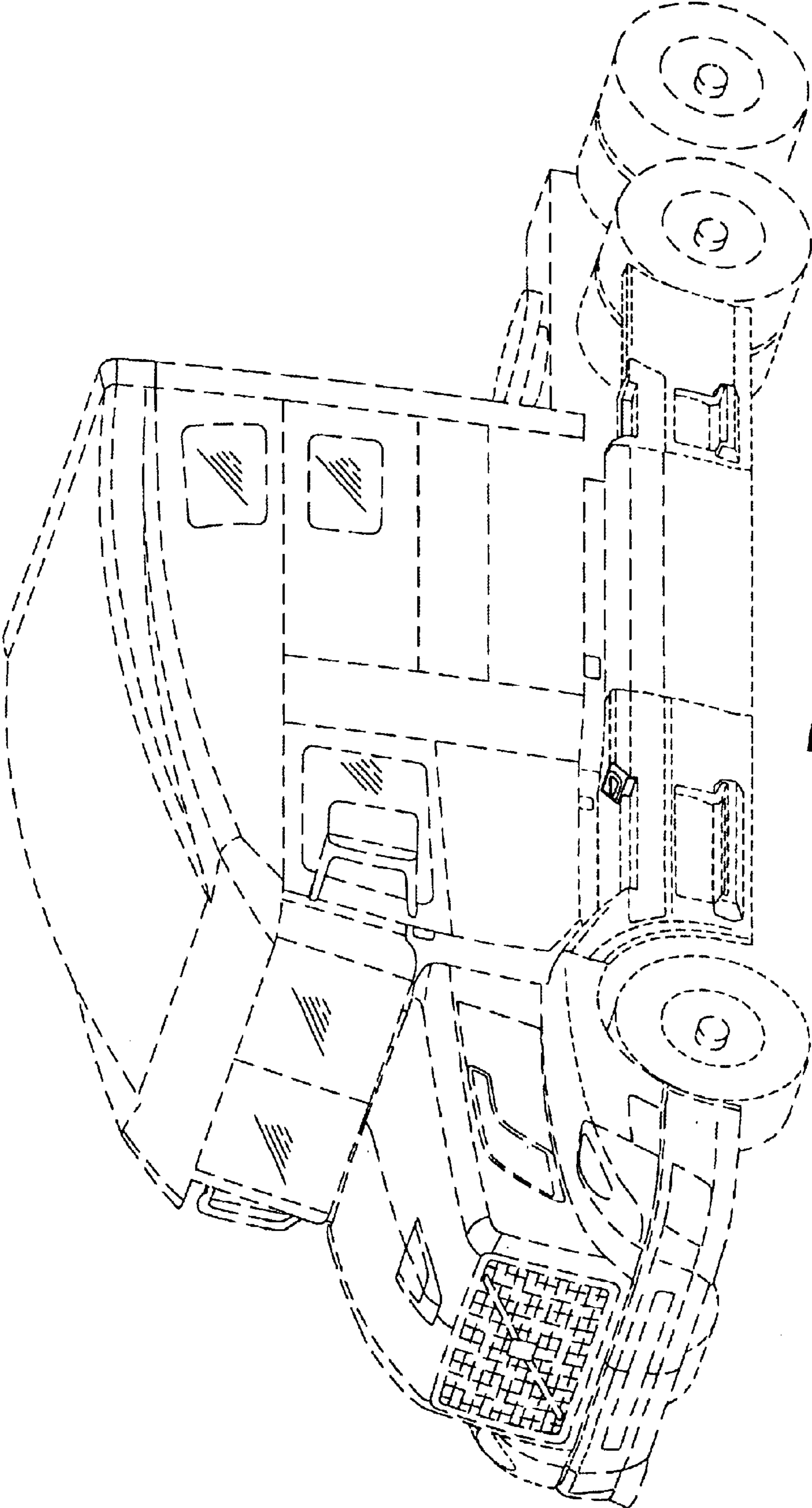

FIG. 1

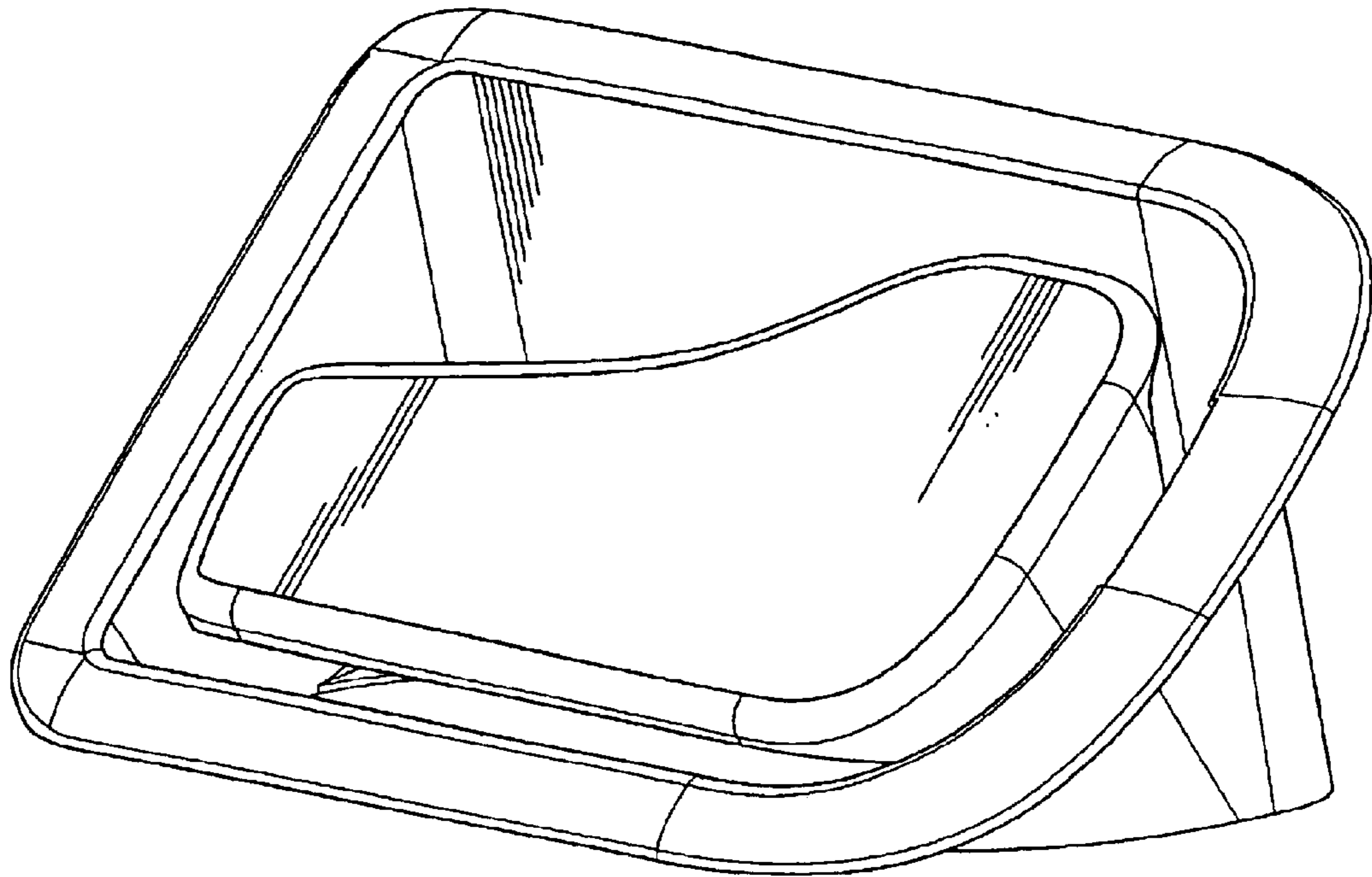

FIG. 2

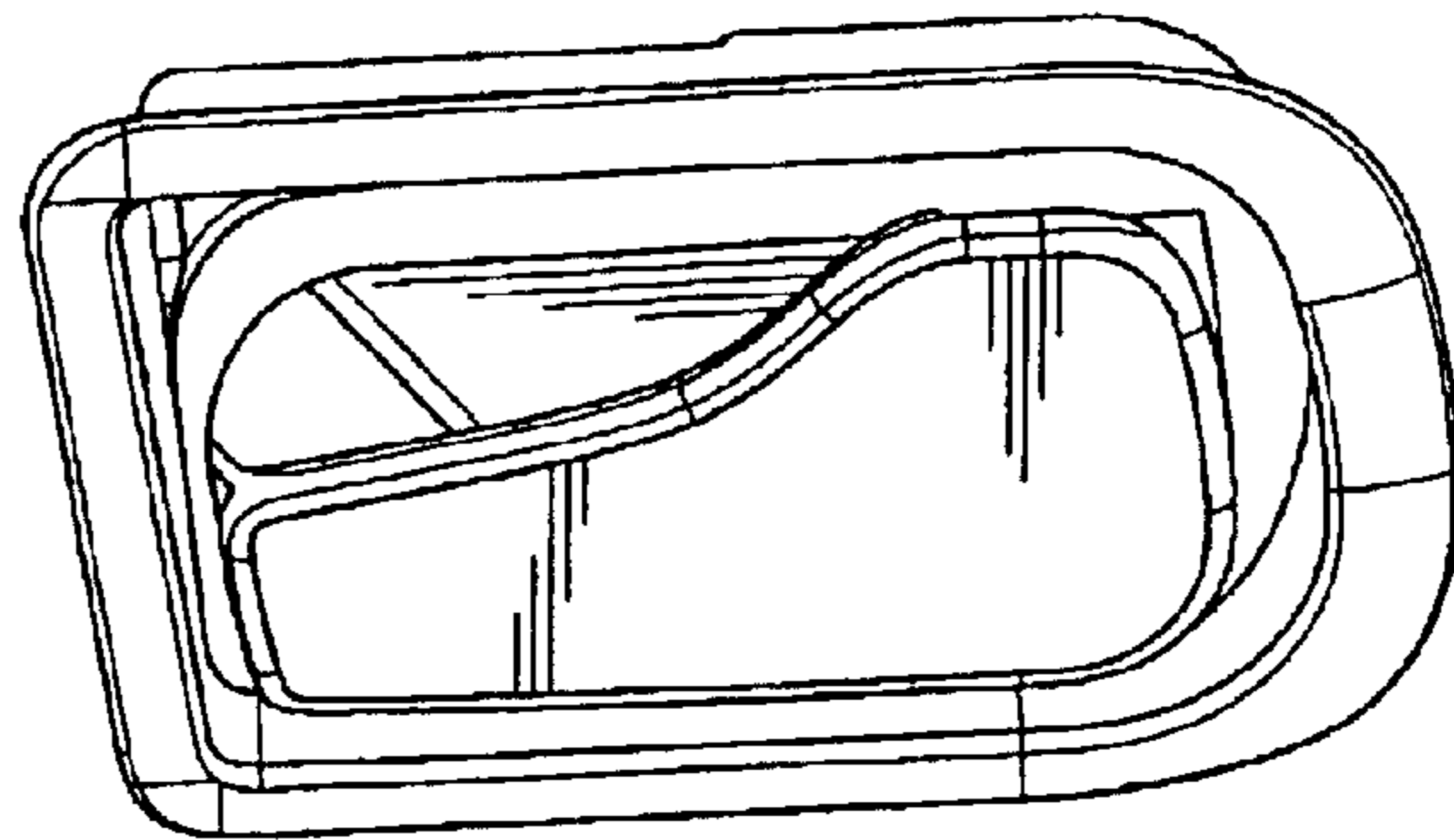

FIG. 3

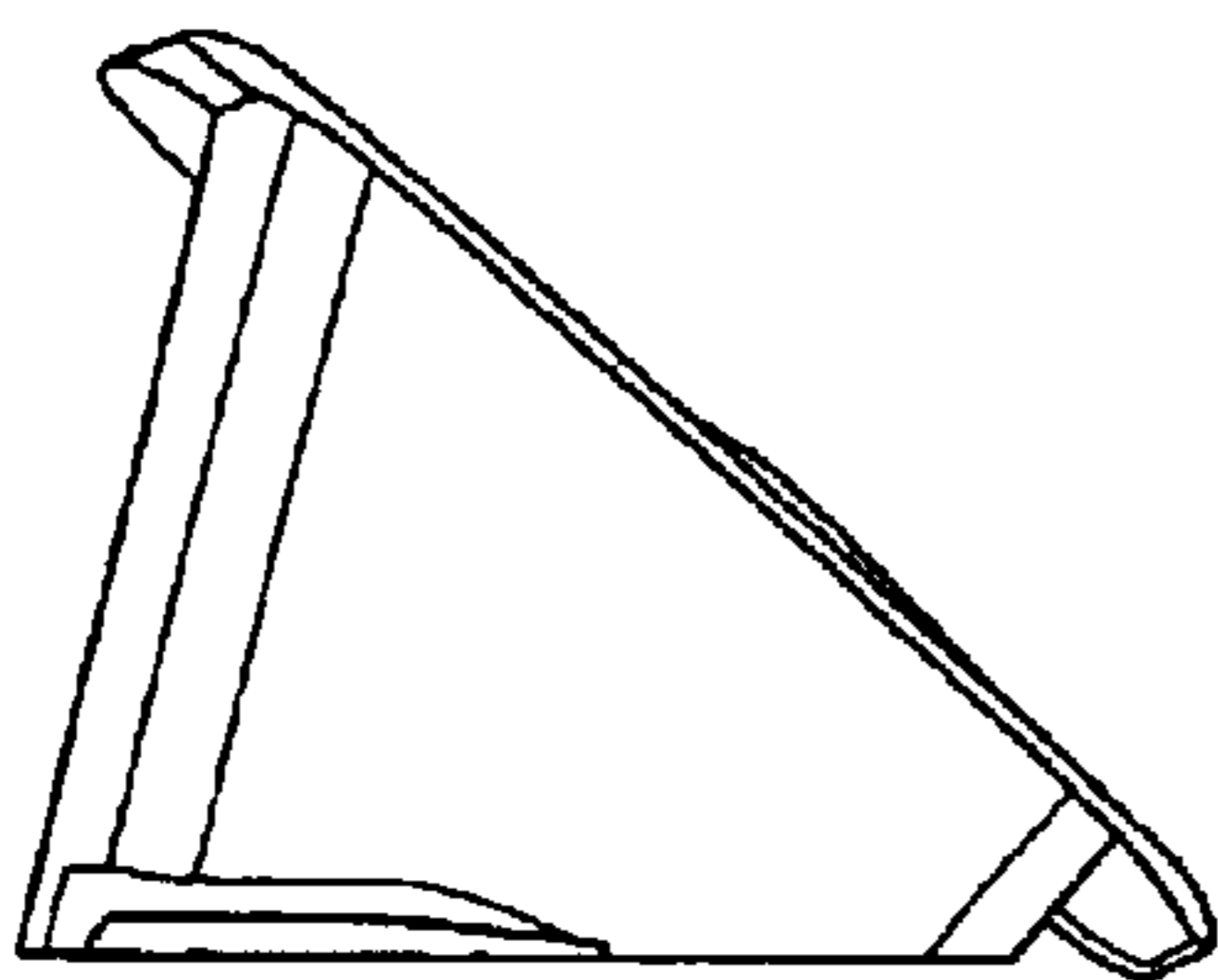

FIG. 4

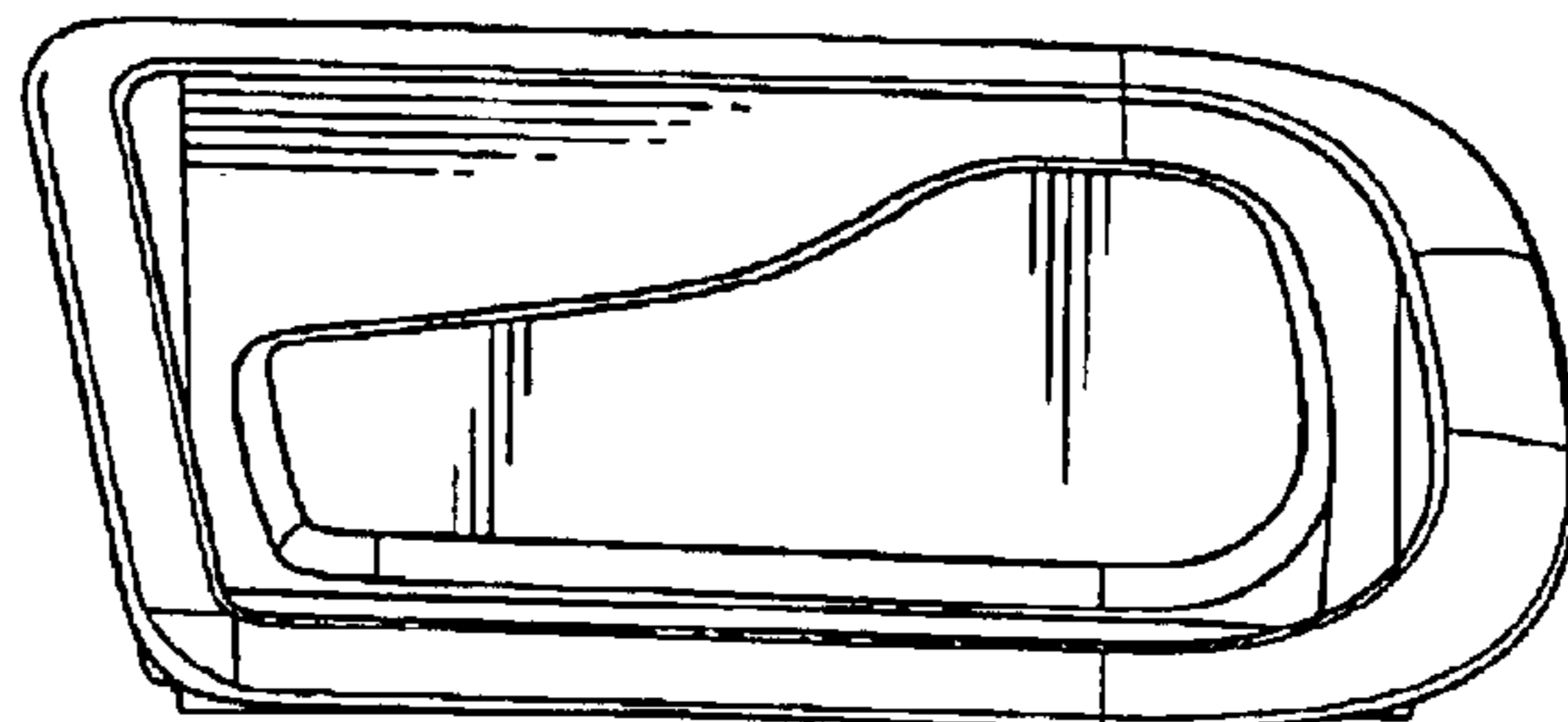

FIG. 5

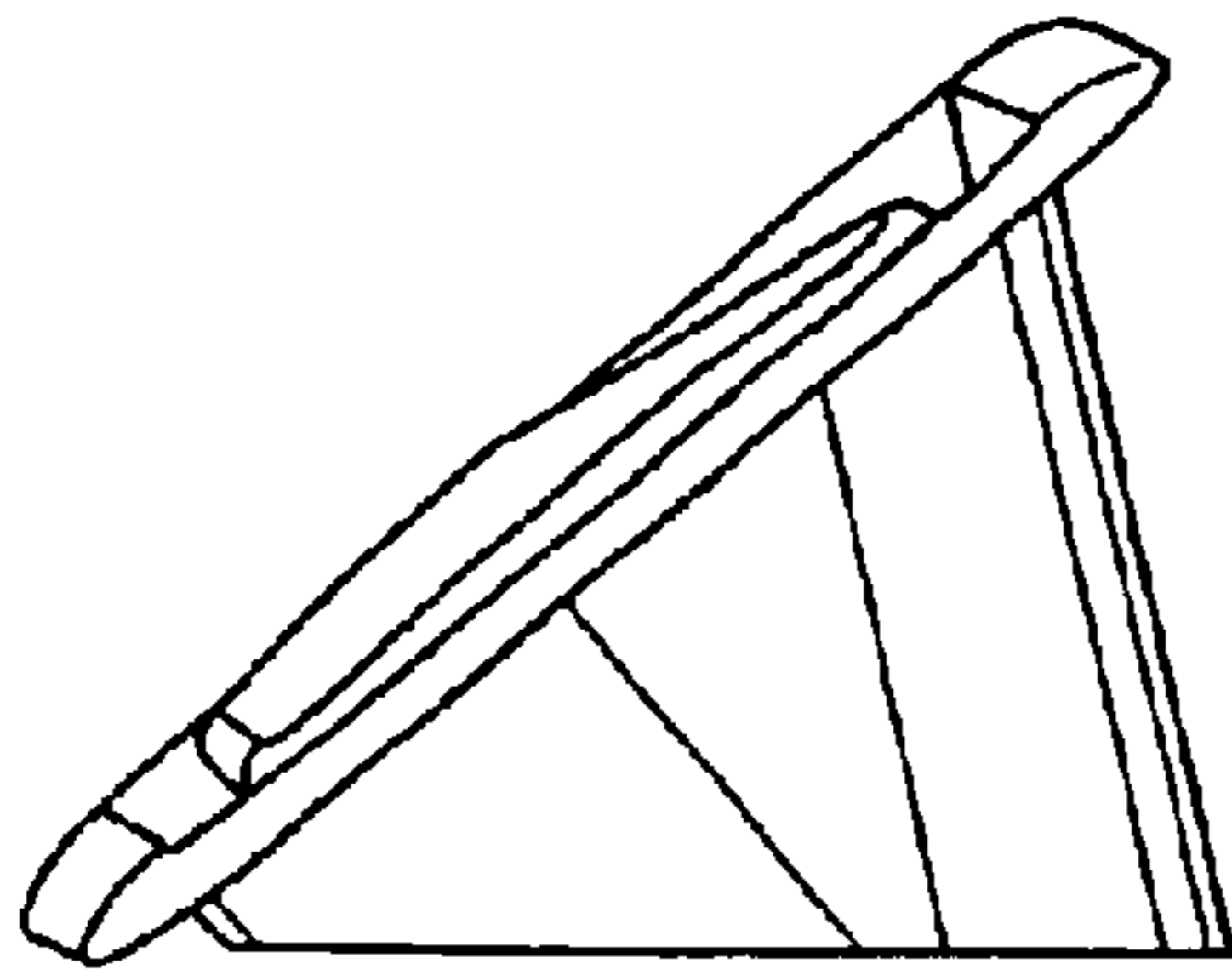

FIG. 6

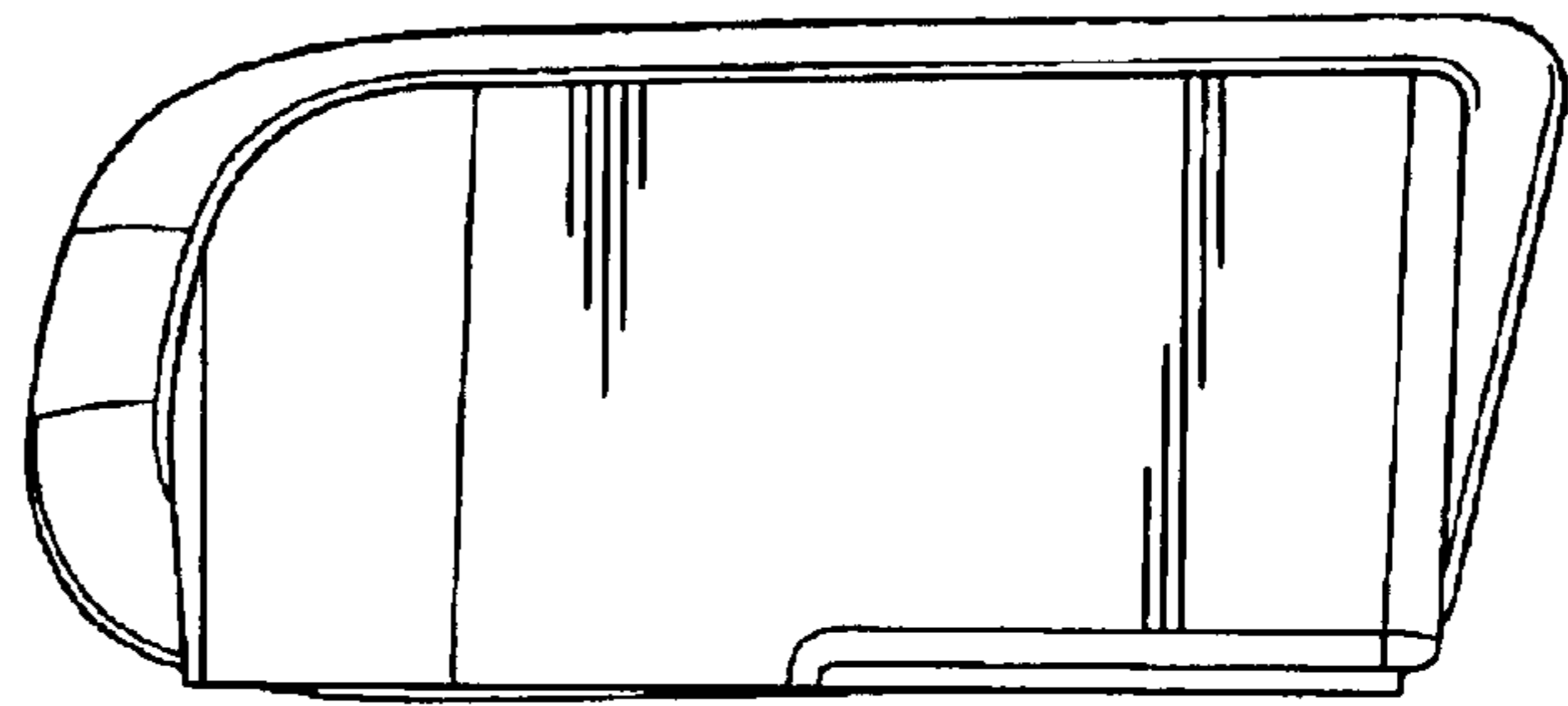

FIG. 7

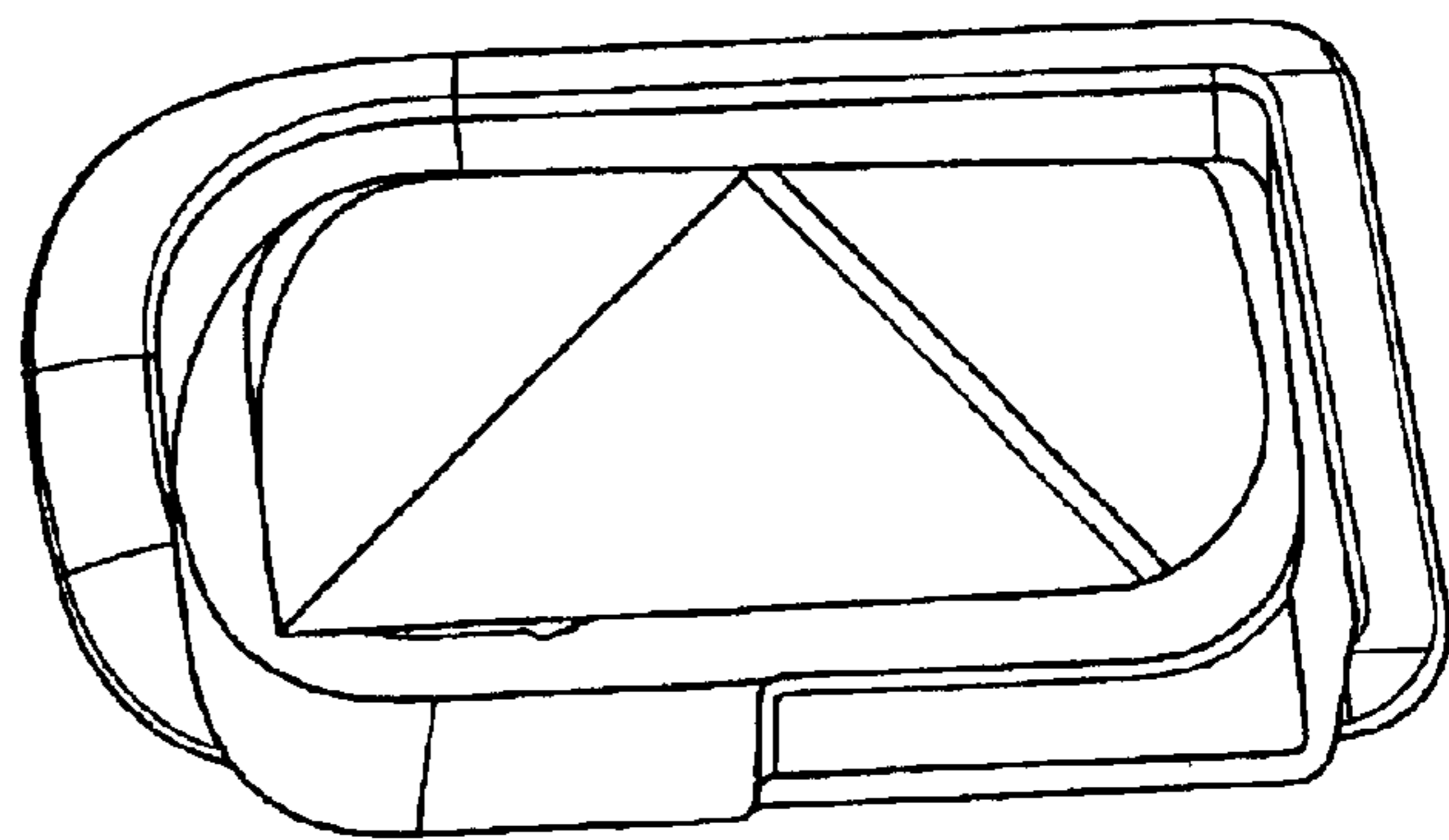

FIG. 8