



US00D498537S

(12) **United States Design Patent**  
**Miller**

(10) **Patent No.:** **US D498,537 S**

(45) **Date of Patent:** **\*\* Nov. 16, 2004**

(54) **ROAD SYSTEM**

(76) Inventor: **N. Craig Miller**, 8676 Vista Del Boca Dr., Boca Raton, FL (US) 33433

(\*\*) Term: **14 Years**

(21) Appl. No.: **29/174,941**

(22) Filed: **Jan. 27, 2003**

**Related U.S. Application Data**

(63) Continuation-in-part of application No. 29/143,524, filed on Jun. 15, 2001, now Pat. No. Des. 472,646, which is a continuation-in-part of application No. 29/137,857, filed on Apr. 27, 2000, now Pat. No. Des. 451,203.

(51) **LOC (7) Cl.** ..... **25-03**

(52) **U.S. Cl.** ..... **D25/1**

(58) **Field of Search** ..... D25/1; 404/1;  
340/933, 928

*Primary Examiner*—Doris Clark

(74) *Attorney, Agent, or Firm*—Frank J. Benasutti

(57) **CLAIM**

I claim the ornamental design of a road system, as shown and described.

**DESCRIPTION**

FIG. 1 is a perspective view of a road system showing my new design;

FIG. 2 is a perspective view of a second embodiment of a road system;

FIG. 3 is a perspective view of a third embodiment of a road system;

FIG. 4 is a perspective view of a fourth embodiment of a road system;

FIG. 5 is a perspective view of a fifth embodiment of a road system;

FIG. 6 is a perspective view of a sixth embodiment of a road system;

FIG. 7 is a perspective view of a seventh embodiment of a road system;

FIG. 8 is a perspective view of an eighth embodiment of a road system;

FIG. 9 is a perspective view of a ninth embodiment of a road system;

FIG. 10 is a perspective view of a tenth embodiment of a road system; and,

FIG. 11 is a perspective view of an eleventh embodiment of a road system.

The road system is shown fragmented throughout the views to indicate that the pattern is repetitive as illustrated in the drawing.

The broken lines are for illustrative purposes only and form no part of the claimed design.

**1 Claim, 11 Drawing Sheets**

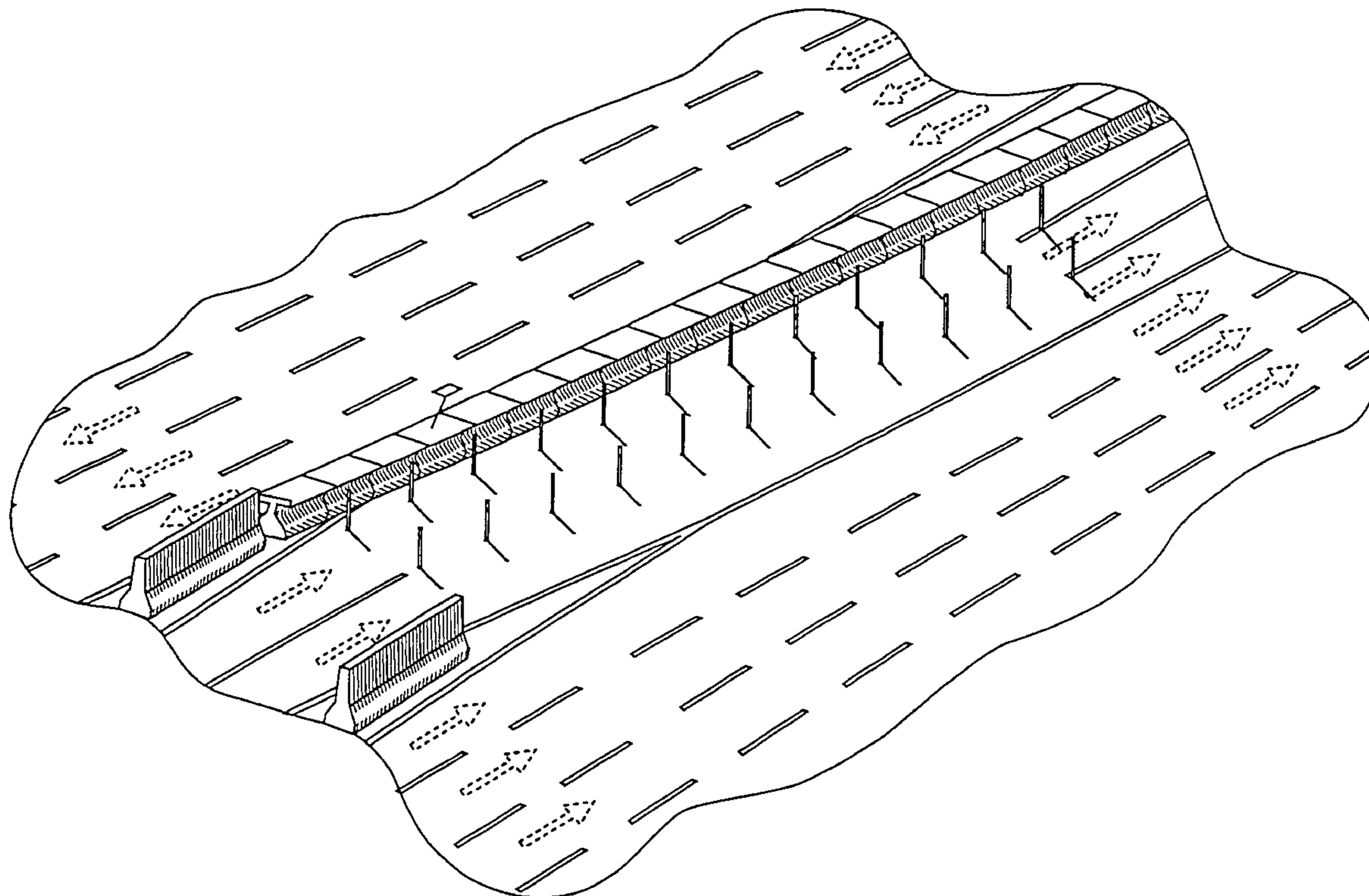

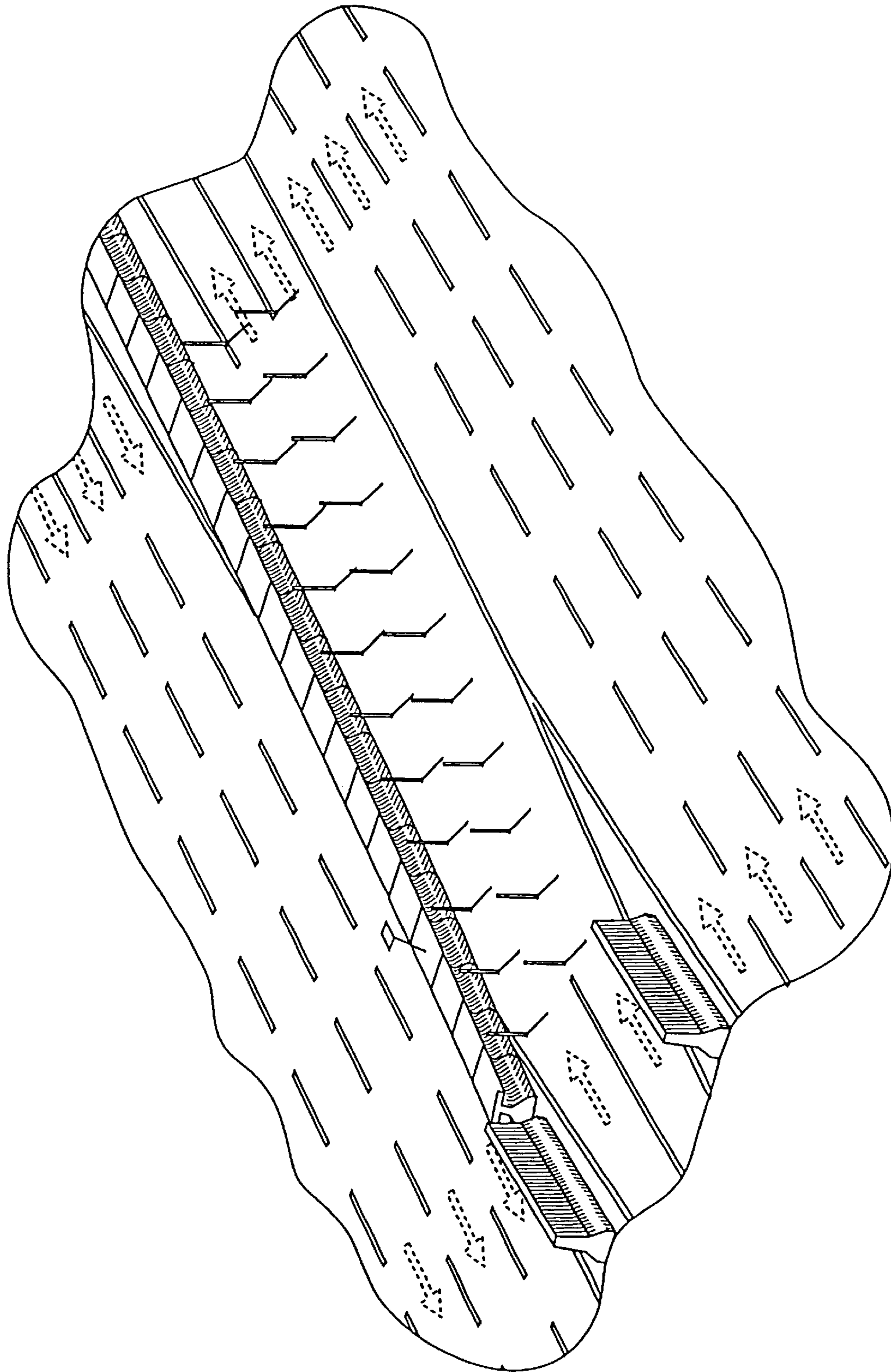

Fig. 1

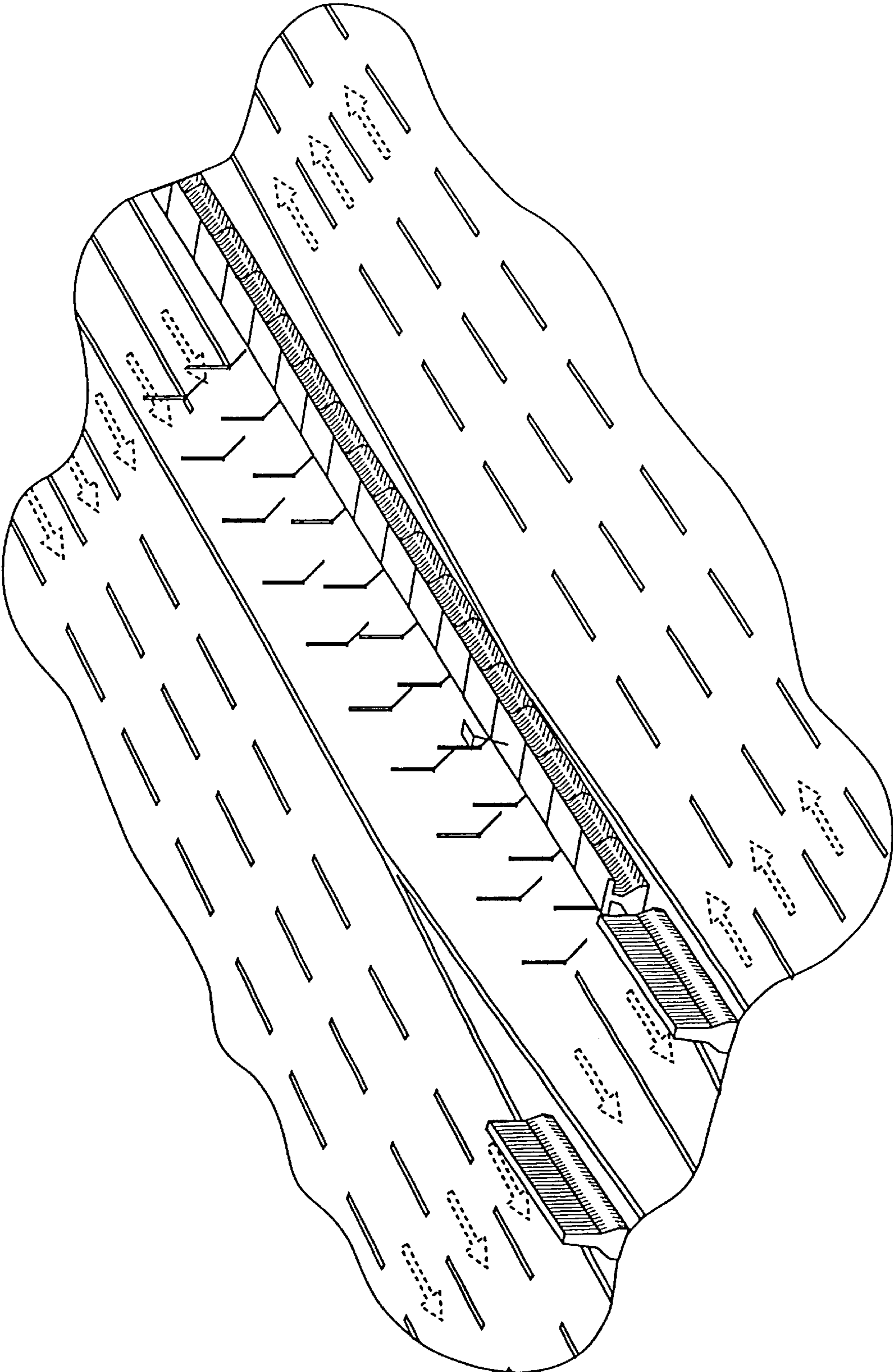

Fig. 2

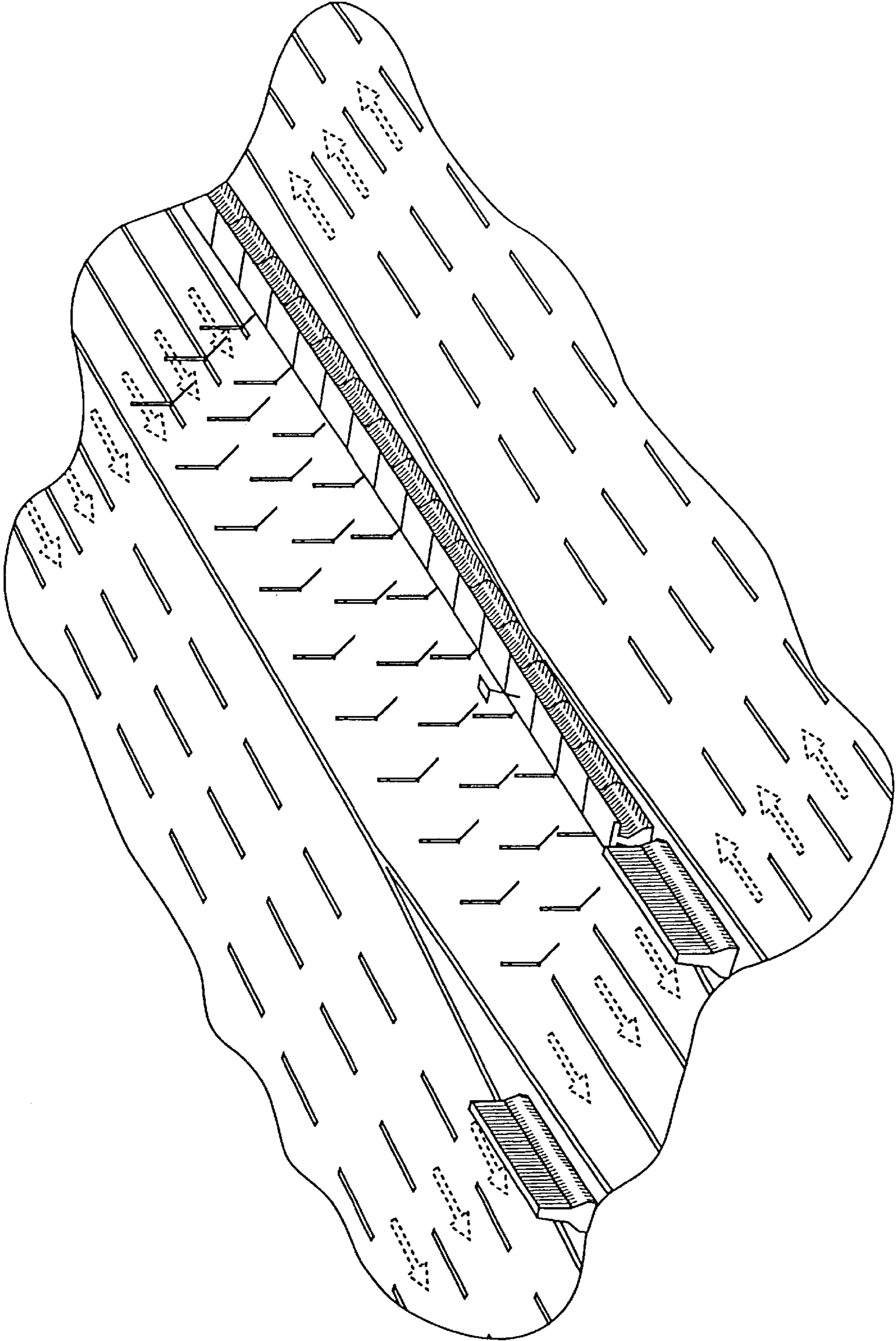

Fig. 3

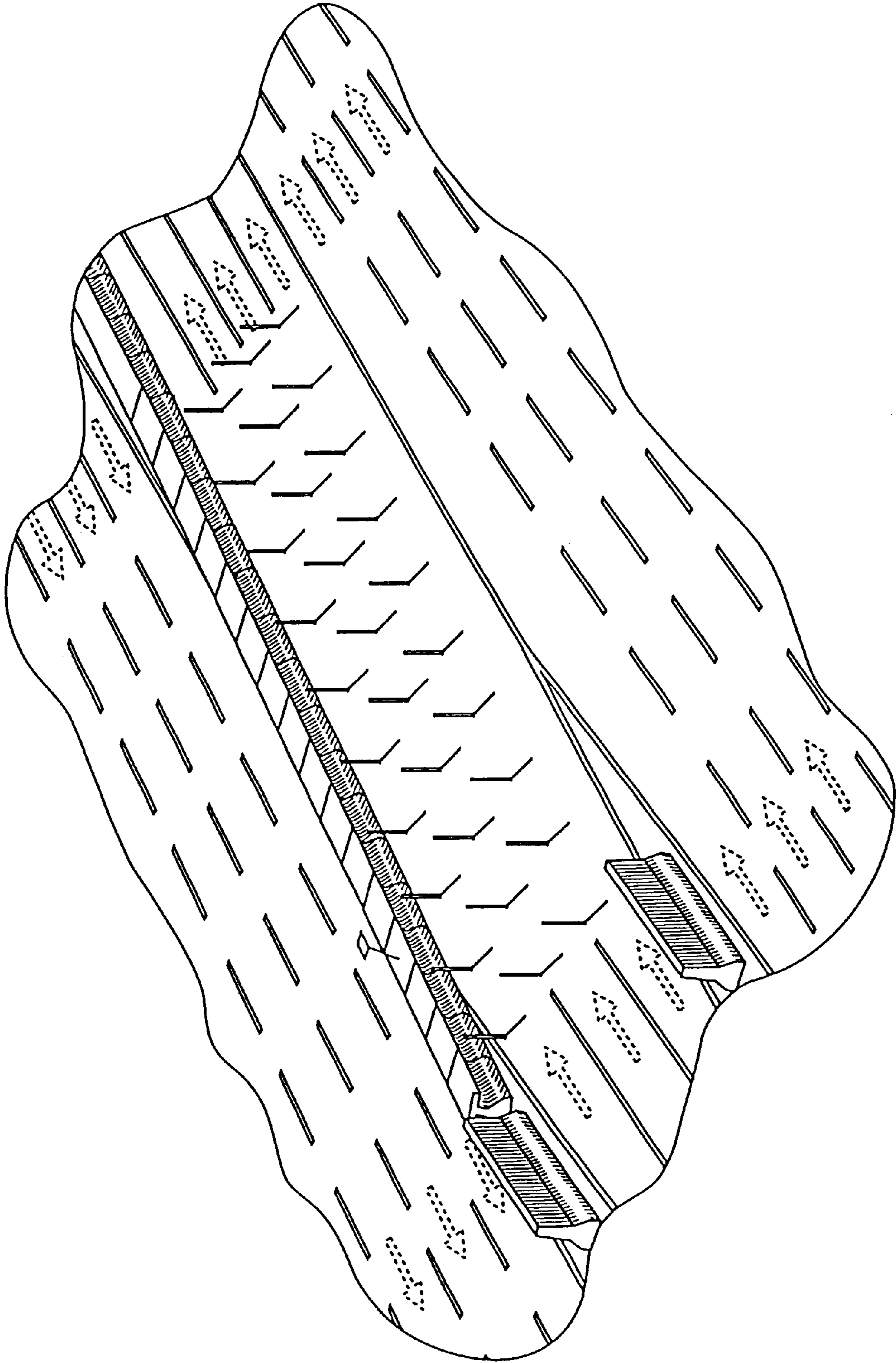

Fig. 4

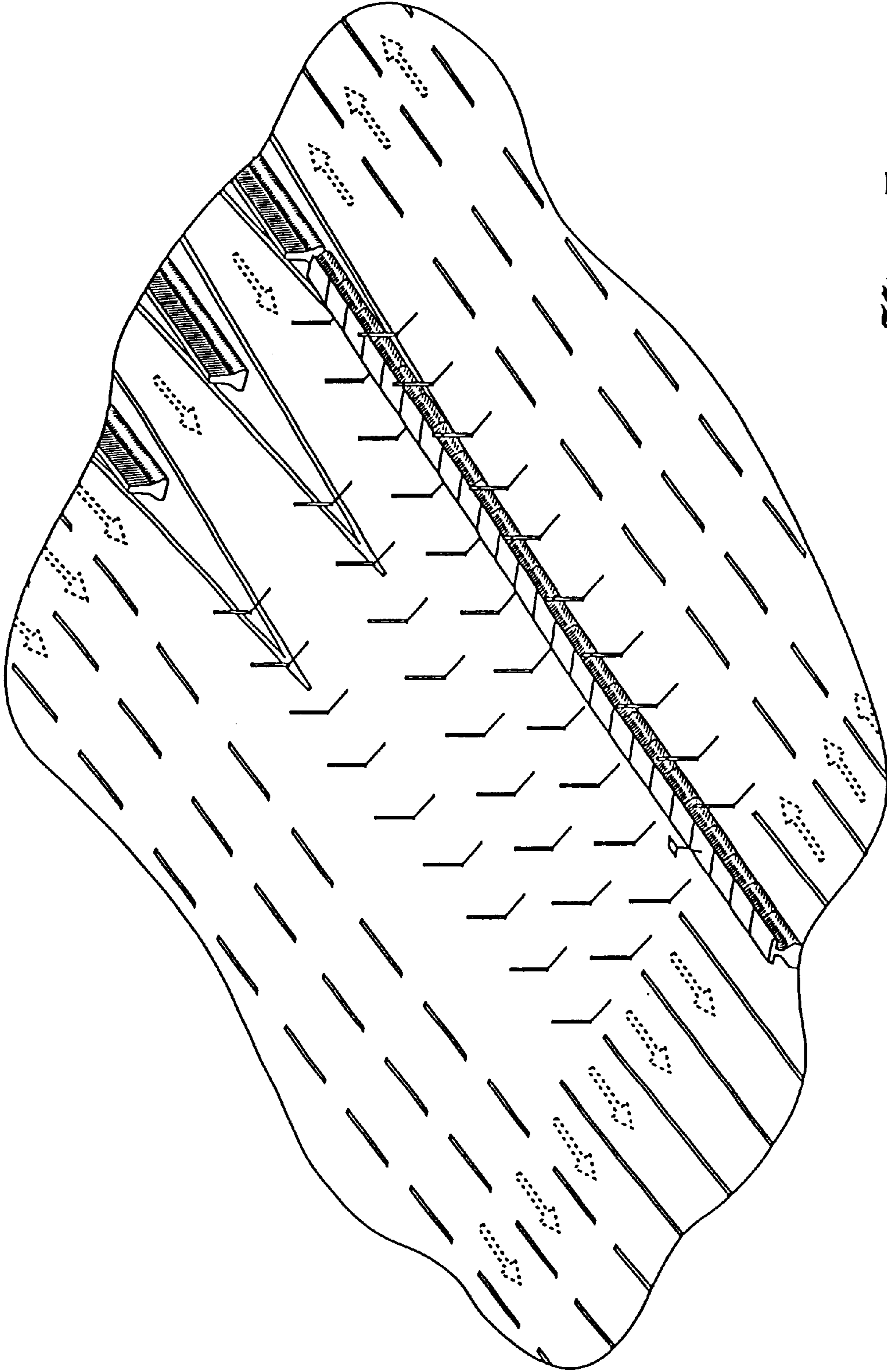

Fig. 5

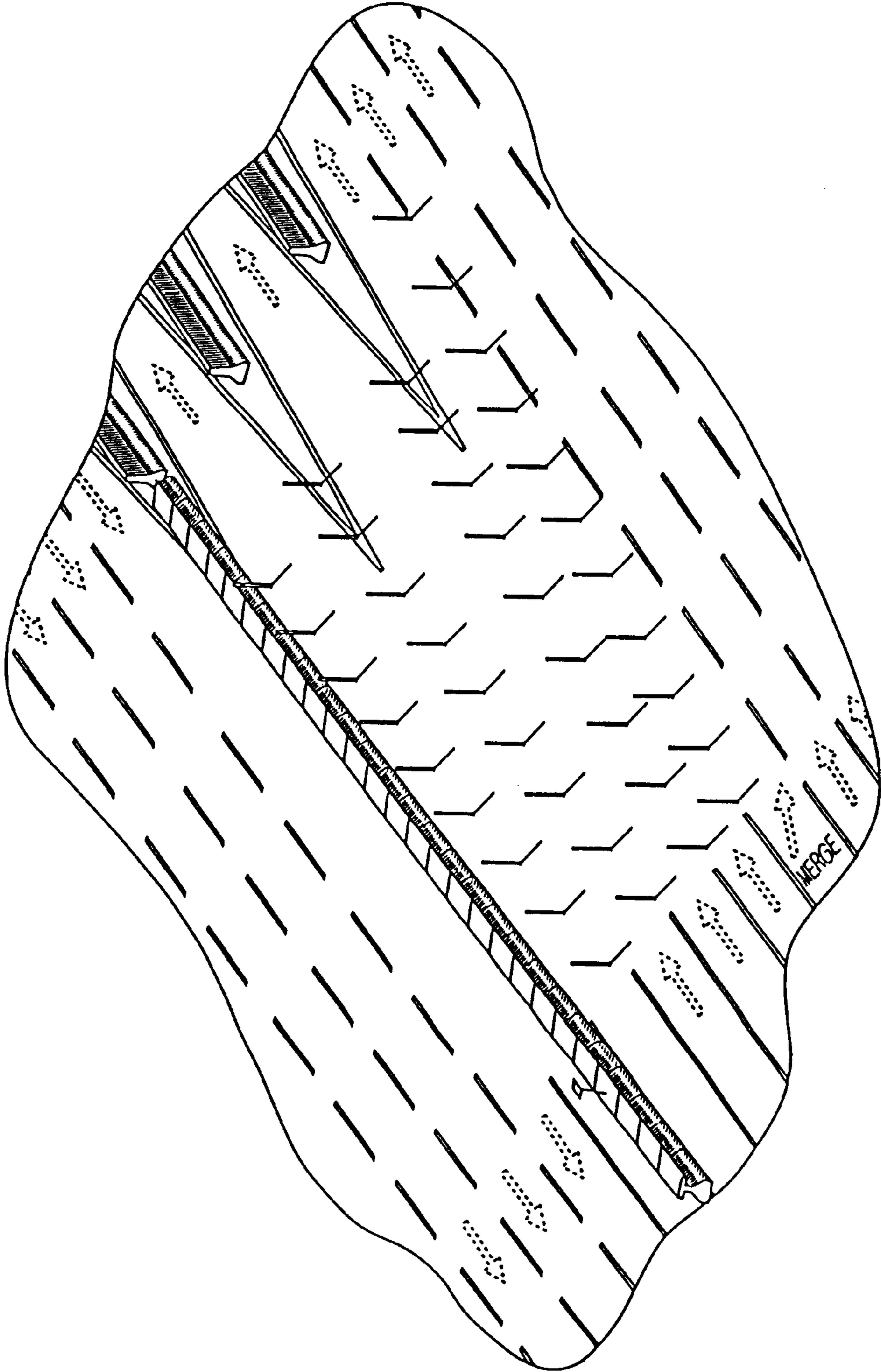

Fig. 6

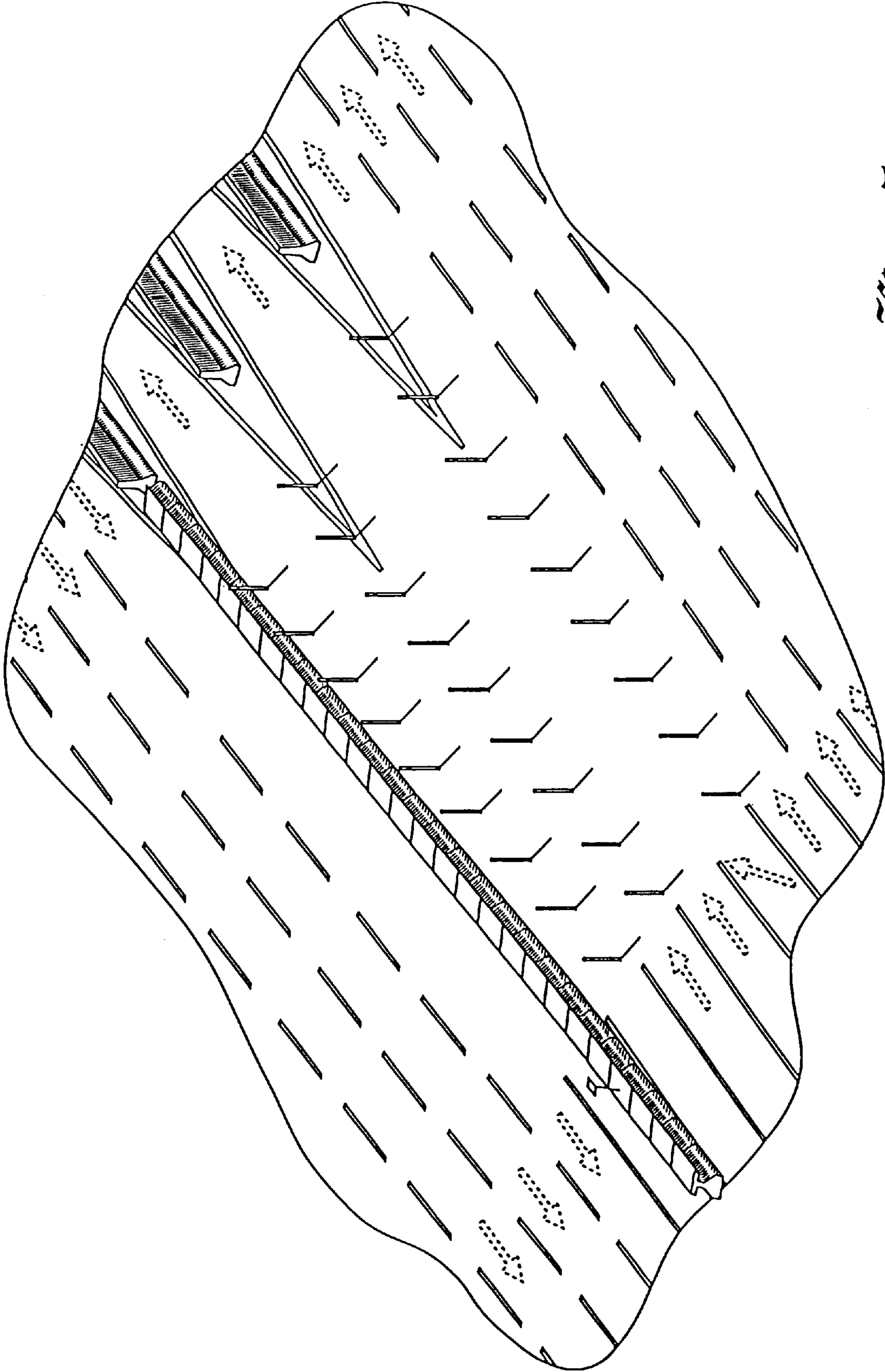

Fig. 7



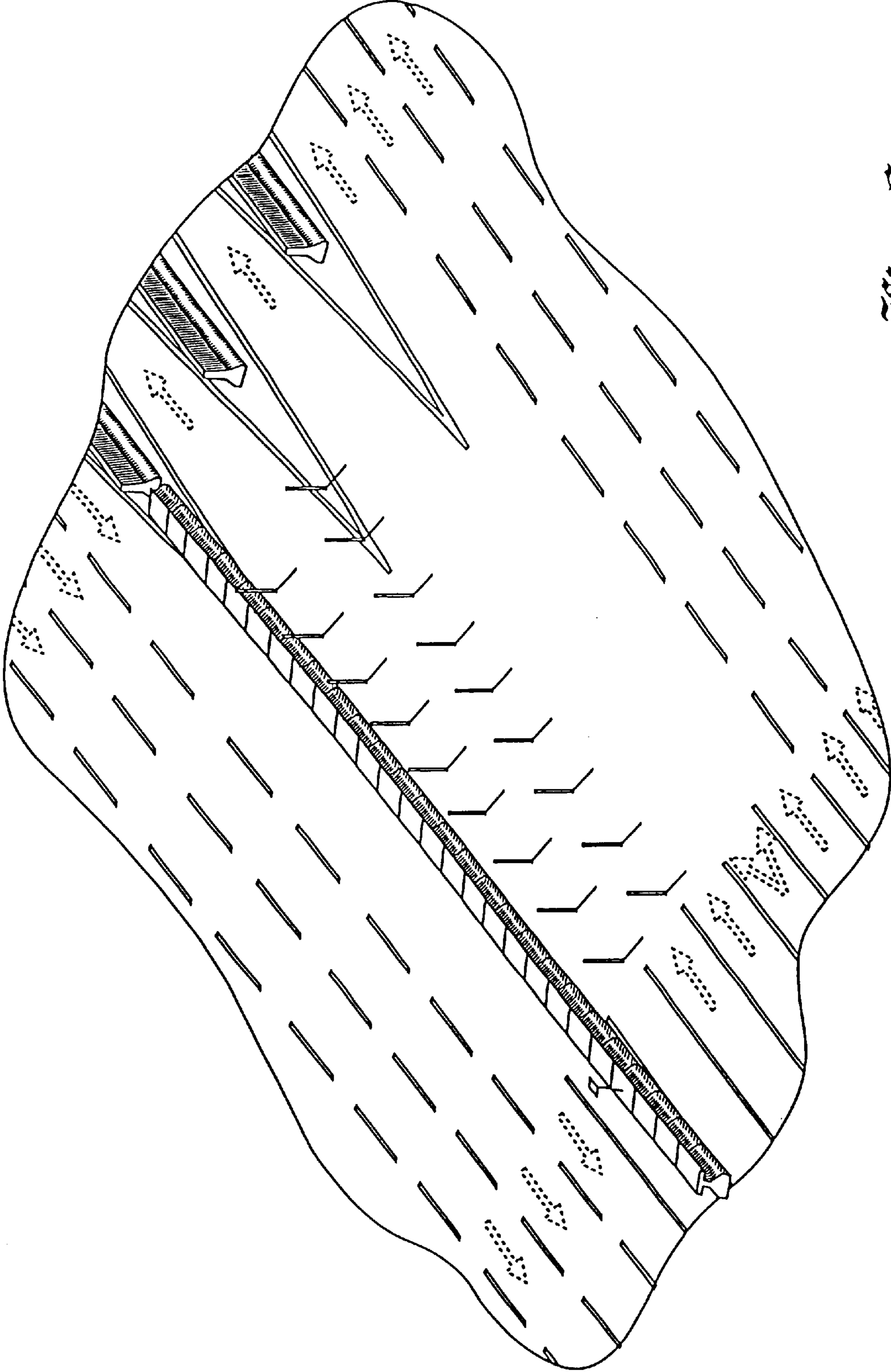

Fig. 8

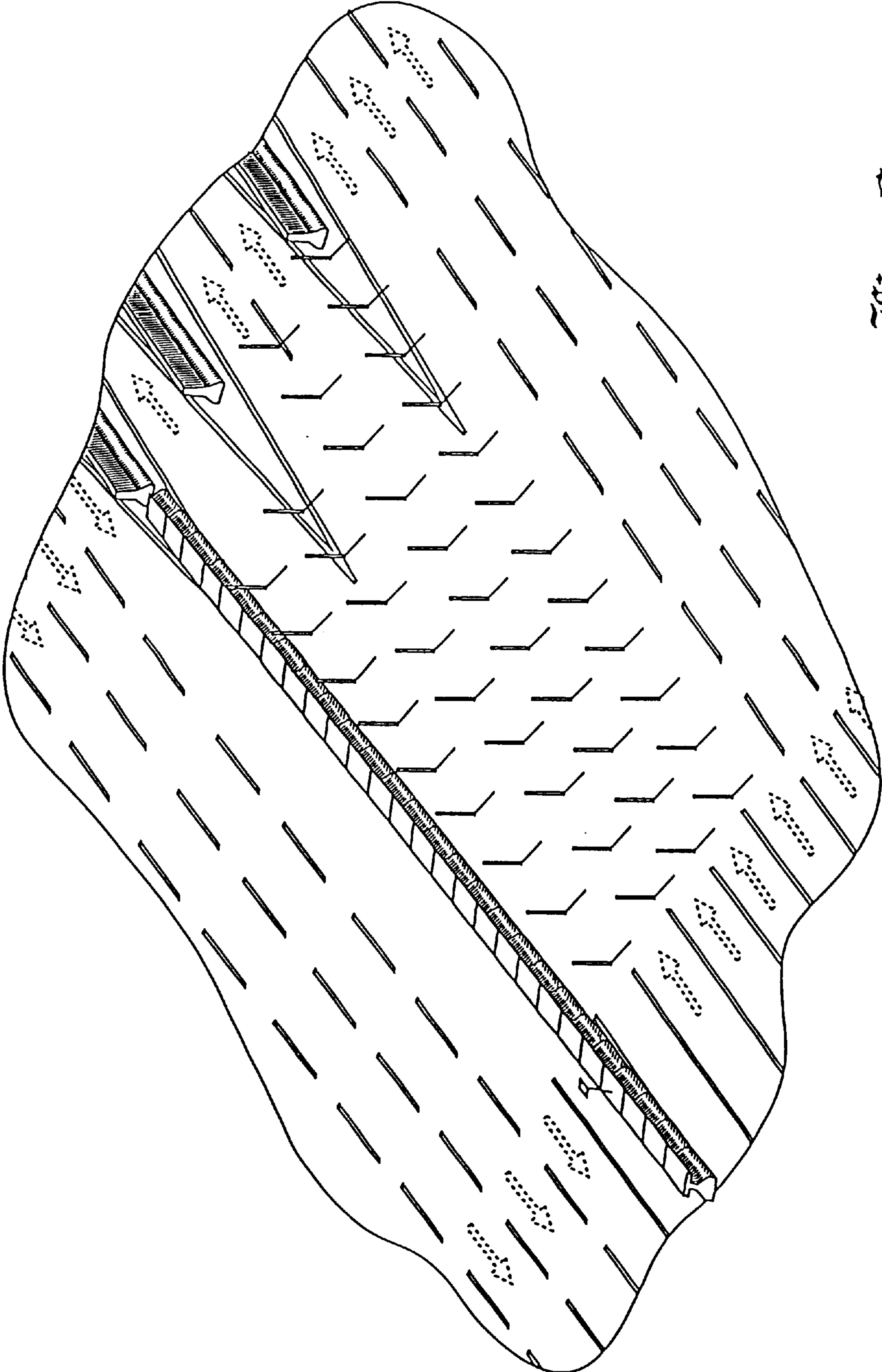

Fig. 9

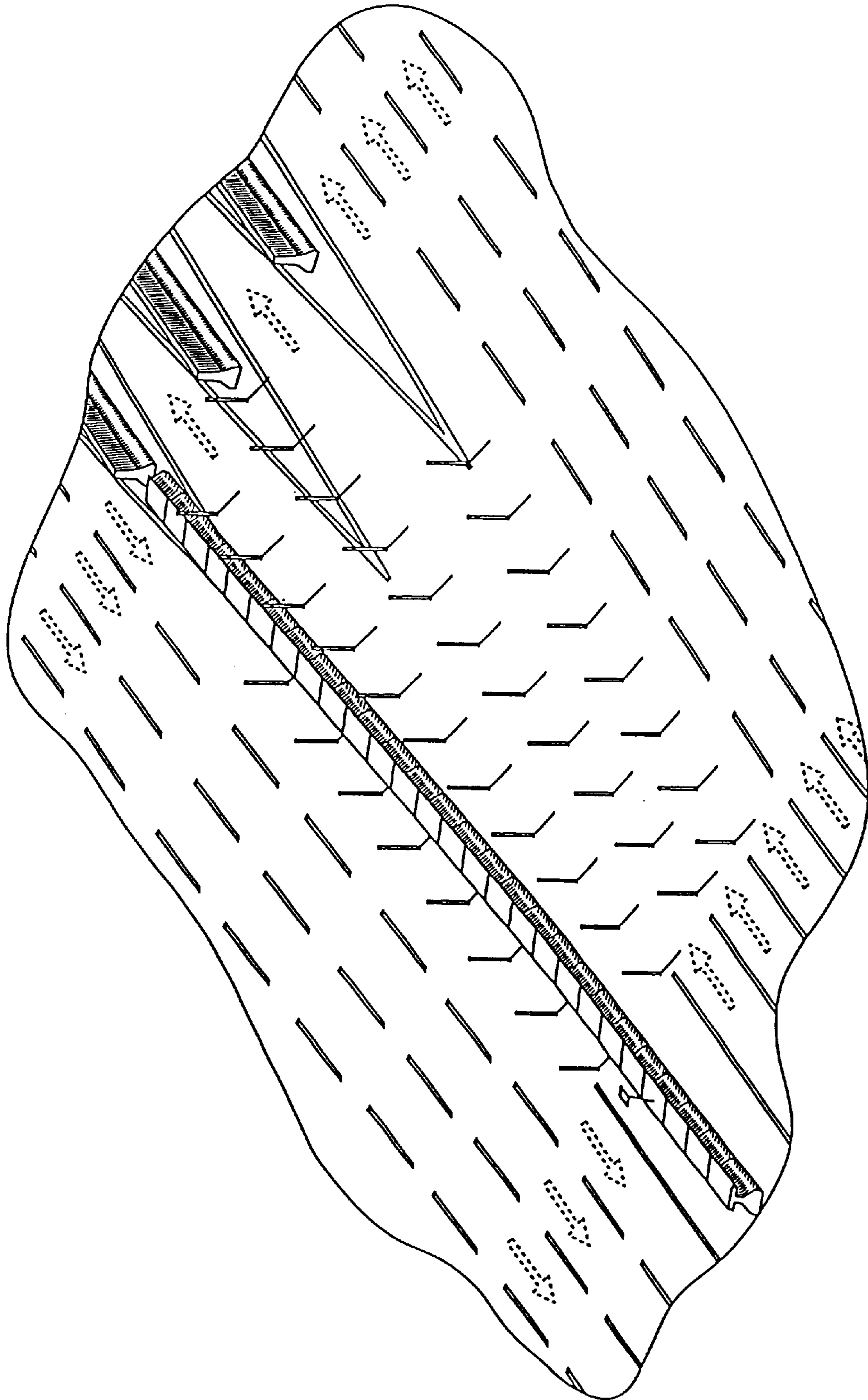

Fig. 10

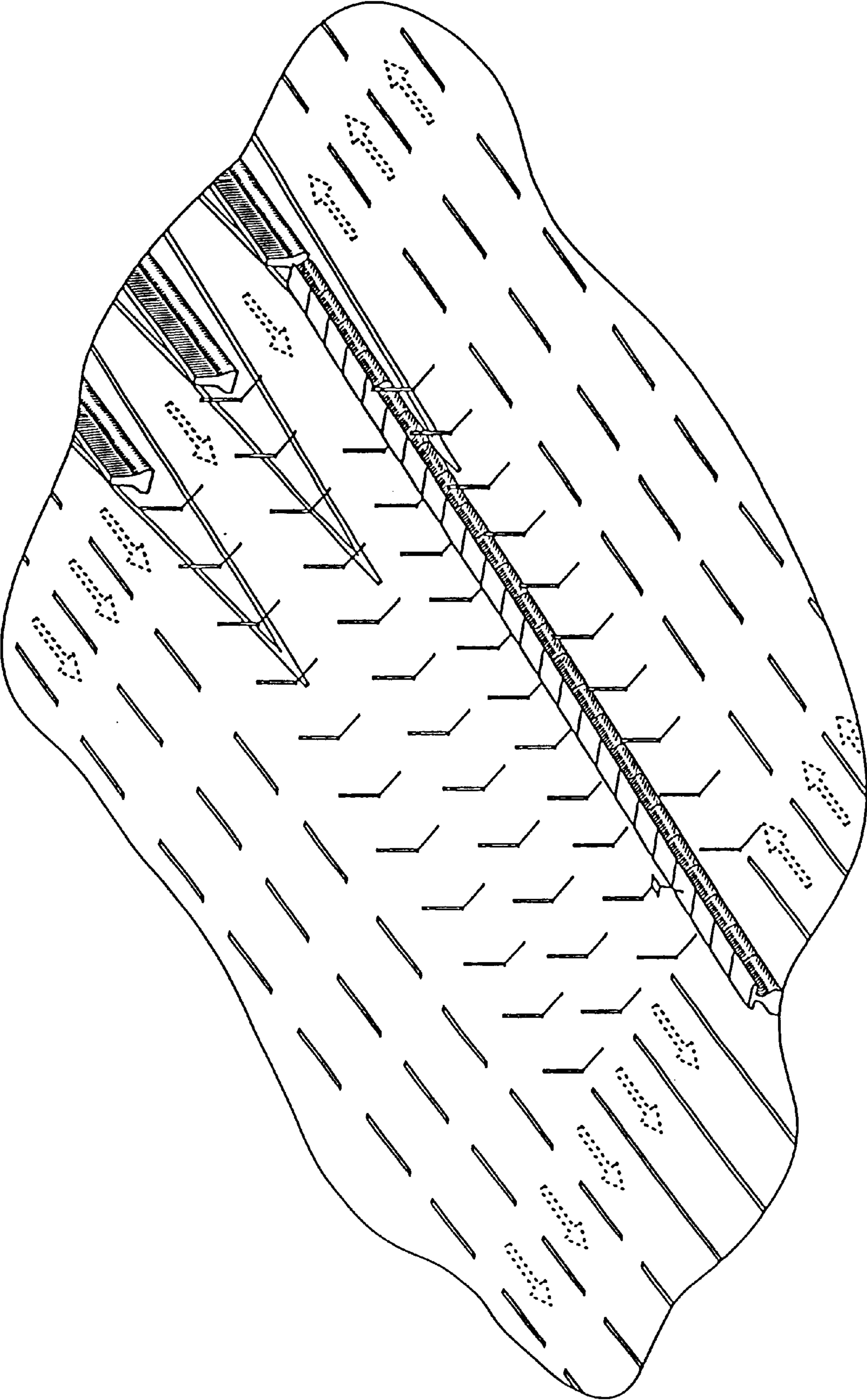

Fig. 11