



US00D498442S

(12) **United States Design Patent**  
**James**

(10) **Patent No.:** **US D498,442 S**

(45) **Date of Patent:** **\*\* Nov. 16, 2004**

(54) **MOTORCYCLE FOOT PEG**

(75) **Inventor:** **Jesse G. James**, Surfside, CA (US)

(73) **Assignee:** **Honda Motor Co., Ltd.**, Tokyo (JP)

(\*\*) **Term:** **14 Years**

(21) **Appl. No.:** **29/195,199**

(22) **Filed:** **Dec. 9, 2003**

(51) **LOC (7) Cl.** ..... **12-11**

(52) **U.S. Cl.** ..... **D12/114**

(58) **Field of Search** ..... D12/110, 114,  
D12/122, 125; 74/560, 564, 594.4, 594.6,  
594.7; 280/291, 288.4; 296/75; 180/219

(56) **References Cited**

**U.S. PATENT DOCUMENTS**

D401,535 S \* 11/1998 Joseph, Jr. .... D12/114  
6,339,972 B1 \* 1/2002 Paris ..... 74/564

\* cited by examiner

*Primary Examiner*—Alan P. Douglas

*Assistant Examiner*—Linda Brooks

(74) *Attorney, Agent, or Firm*—Plumsea Law Group, LLC

(57) **CLAIM**

The ornamental design for a motorcycle foot peg, as shown and described.

**DESCRIPTION**

FIG. 1 is a perspective view of a motorcycle foot peg showing my new design;

FIG. 2 is a top plan view thereof; and,

FIG. 3 is a front elevational view thereof, the rear elevational view being a mirror image thereof.

The broken line showing of the mounting portion of the motorcycle is for illustrative purposes only and form no part of the claimed invention.

**1 Claim, 2 Drawing Sheets**

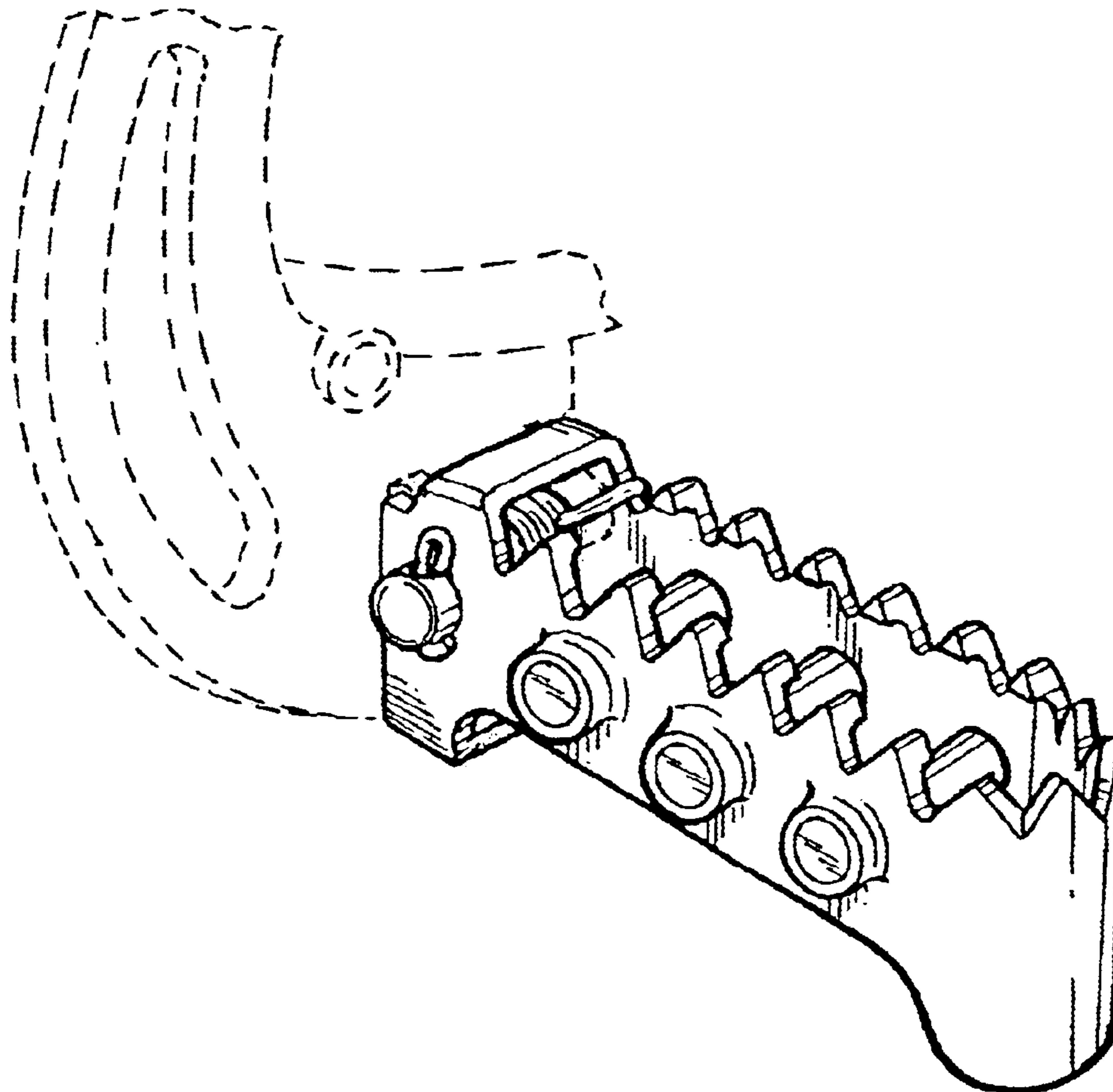

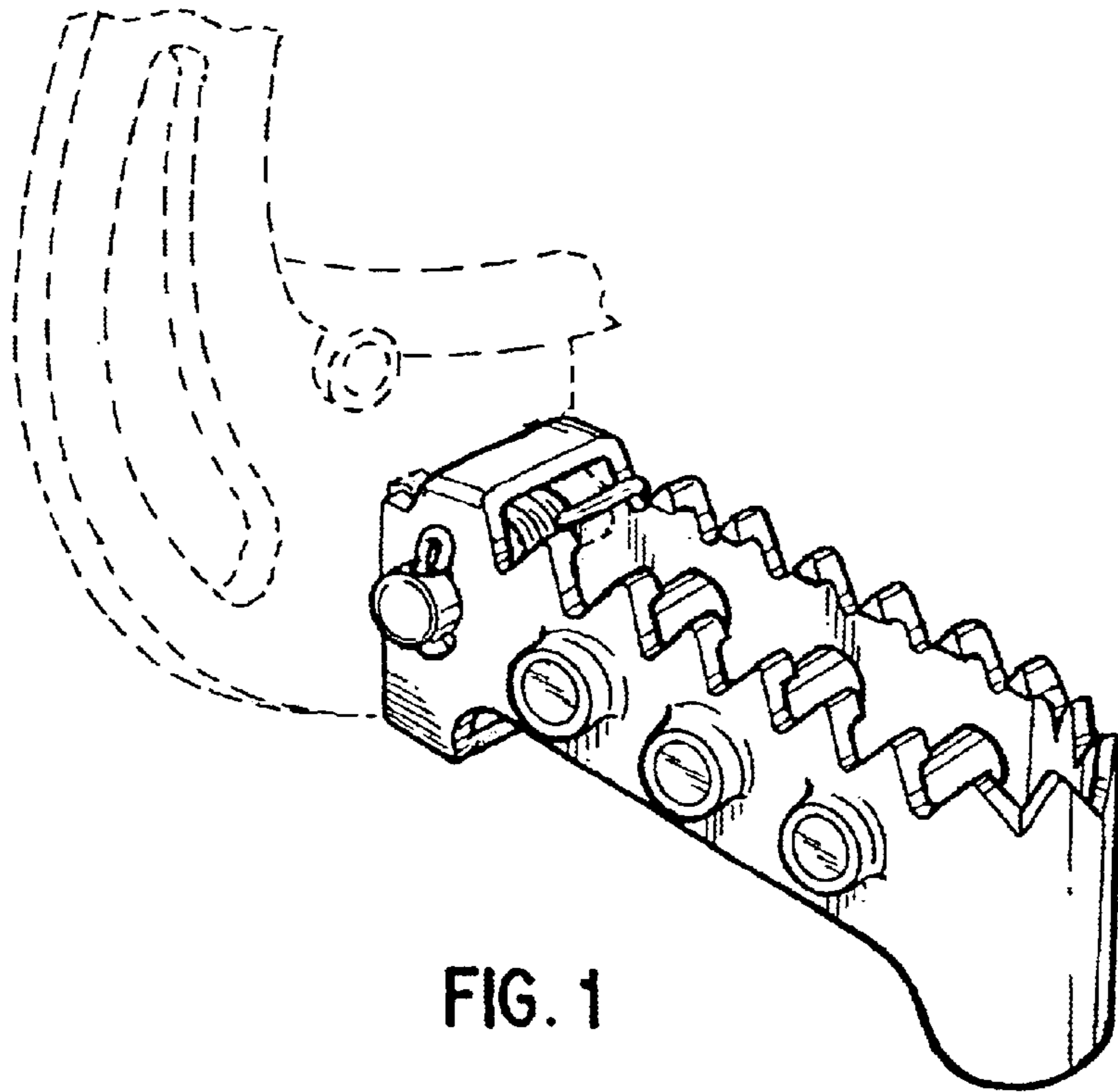

FIG. 1

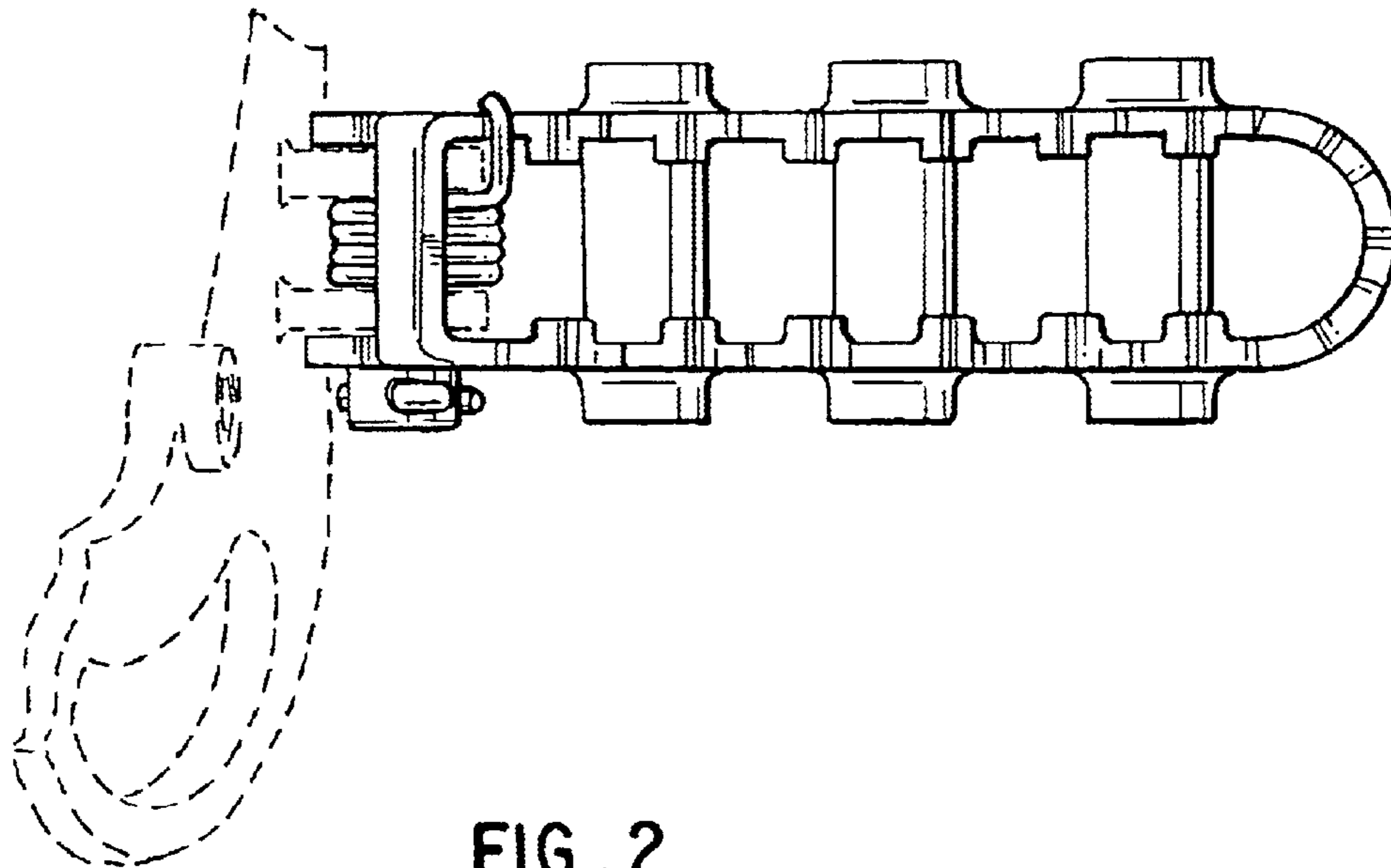

FIG. 2

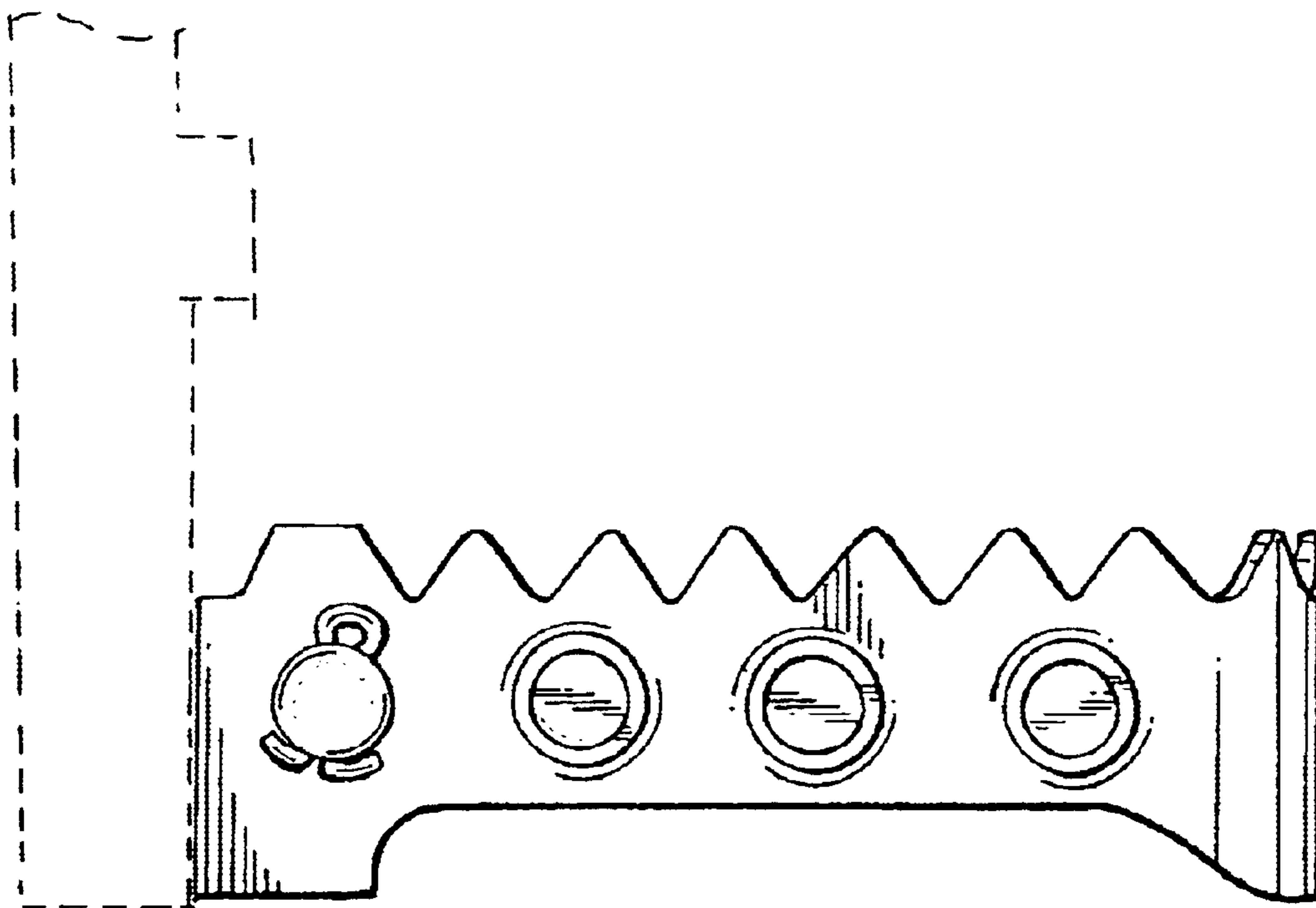

FIG. 3