

US00D498177S

(12) **United States Design Patent** (10) **Patent No.:** **US D498,177 S**  
**Ragle et al.** (45) **Date of Patent:** **\*\* Nov. 9, 2004**

- (54) **AUTOMOBILE BODY**
- (75) Inventors: **Gary Ragle**, Huntington Beach, CA (US); **Chris Schuttera**, Trabuco Canyon, CA (US); **Wallace R. Preston**, Orange, CA (US); **Richard Plavetich**, Laguna Beach, CA (US)
- (73) Assignee: **Mitsubishi Jidosha Kogyo Kabushiki Kaisha**, Tokyo (JP)
- (\*\*) Term: **14 Years**
- (21) Appl. No.: **29/194,475**
- (22) Filed: **Nov. 26, 2003**
- (51) **LOC (7) Cl.** ..... **12-08**
- (52) **U.S. Cl.** ..... **D12/91**
- (58) **Field of Search** ..... D12/90-92, 86, D12/98; D21/424, 433; 296/183, 185, 39.1, 39.2

- D456,311 S \* 4/2002 Yamamoto et al. .... D12/86
- D458,871 S \* 6/2002 Honda et al. .... D12/92
- D461,433 S \* 8/2002 James et al. .... D12/98
- D474,716 S \* 5/2003 Wakao ..... D12/91

\* cited by examiner

*Primary Examiner*—Melody N. Brown  
 (74) *Attorney, Agent, or Firm*—Birch, Stewart, Kolasch & Birch, LLP

(57) **CLAIM**

The ornamental design for an automobile body, as shown and described.

**DESCRIPTION**

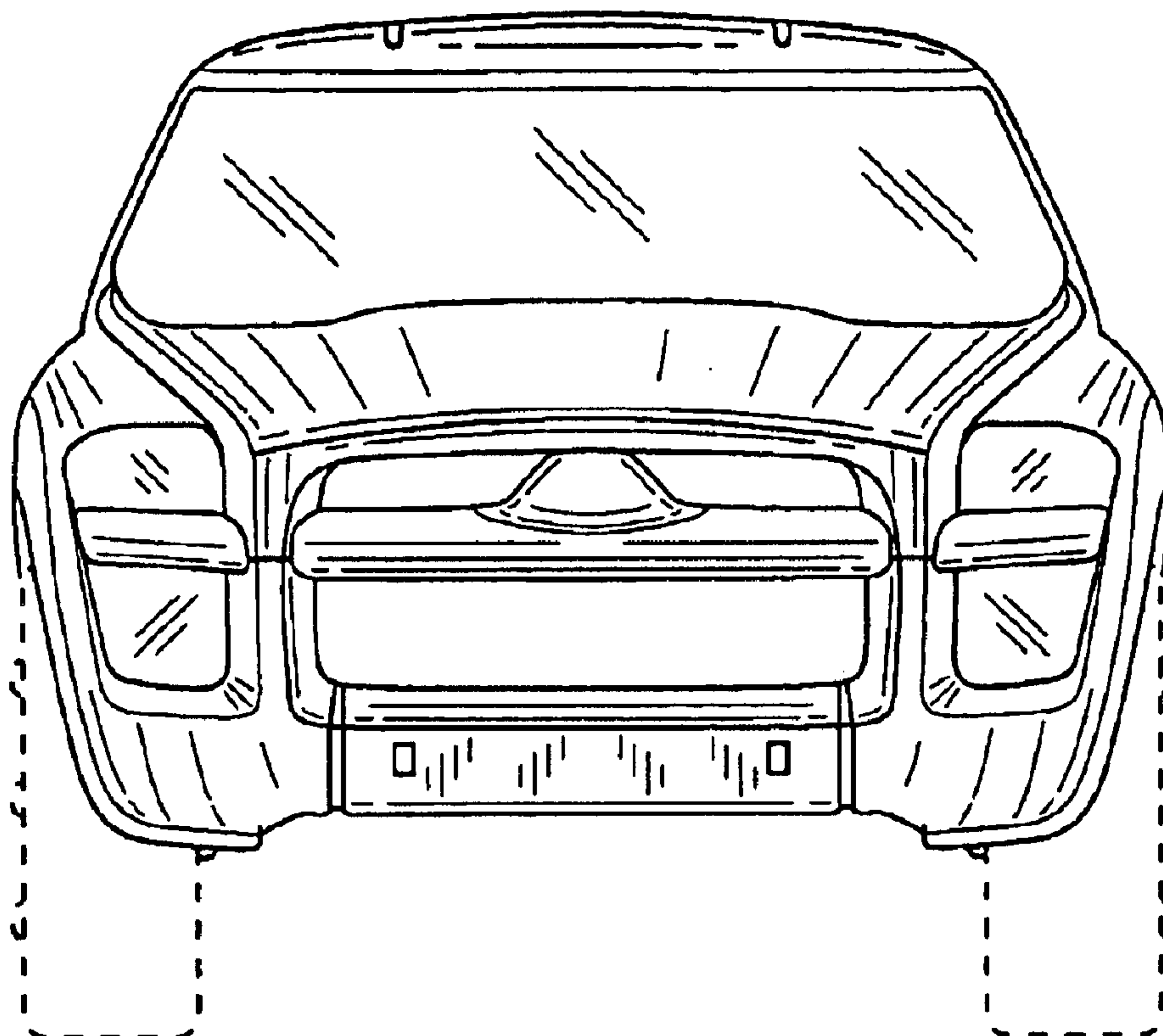
FIG. 1 is a front view of an automobile body constructed according to our novel design;  
 FIG. 2 is a right side view thereof;  
 FIG. 3 is a top plan view thereof; and,  
 FIG. 4 is a rear view thereof.  
 The broken lines showing of environmental structure in FIGS. 1-4 of the drawings are for illustrative purposes only and form no part of the claimed design.  
 Left side view has been omitted because it is substantially symmetrical to the right side view shown in FIG. 2.

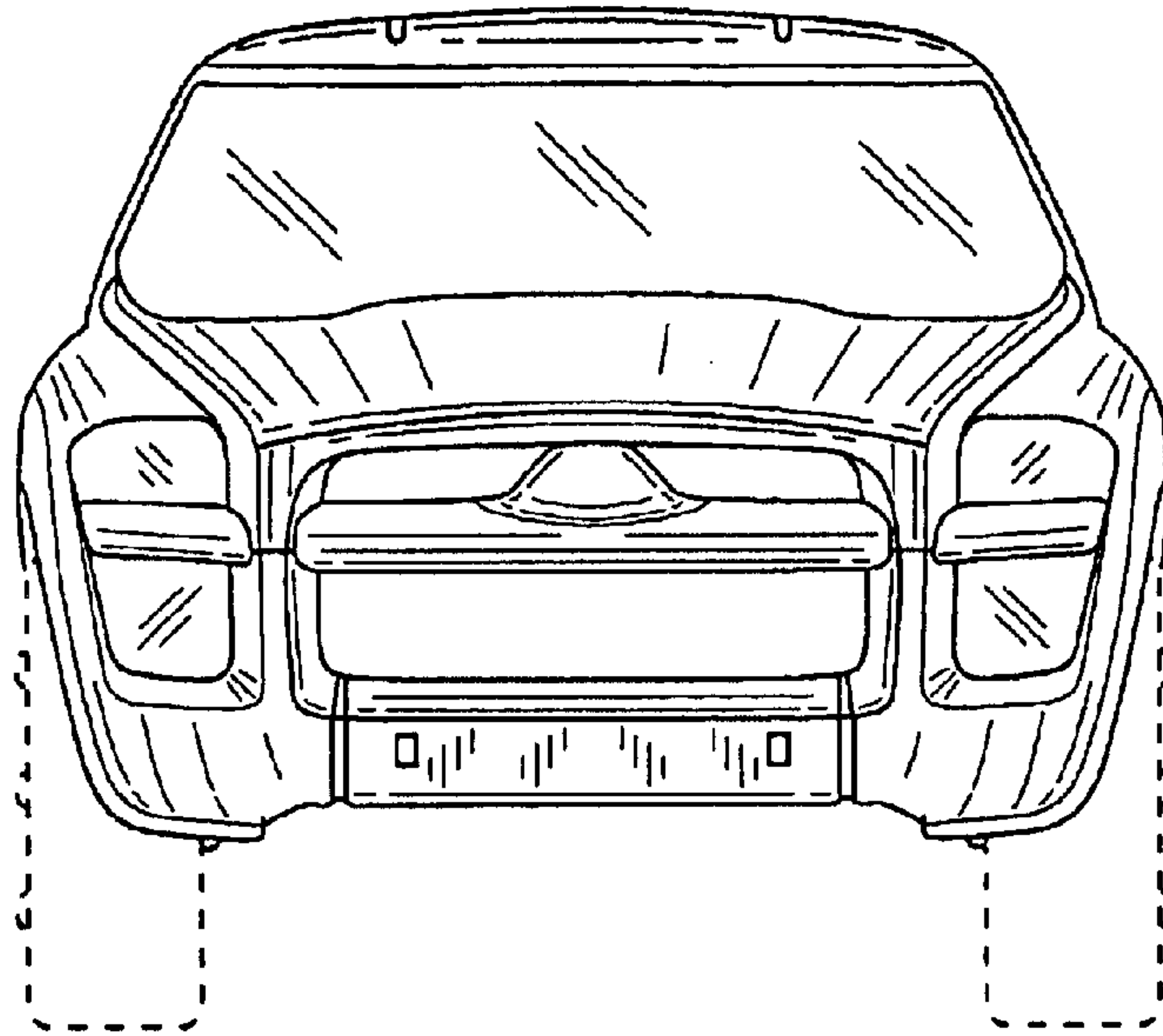
(56) **References Cited**

**U.S. PATENT DOCUMENTS**

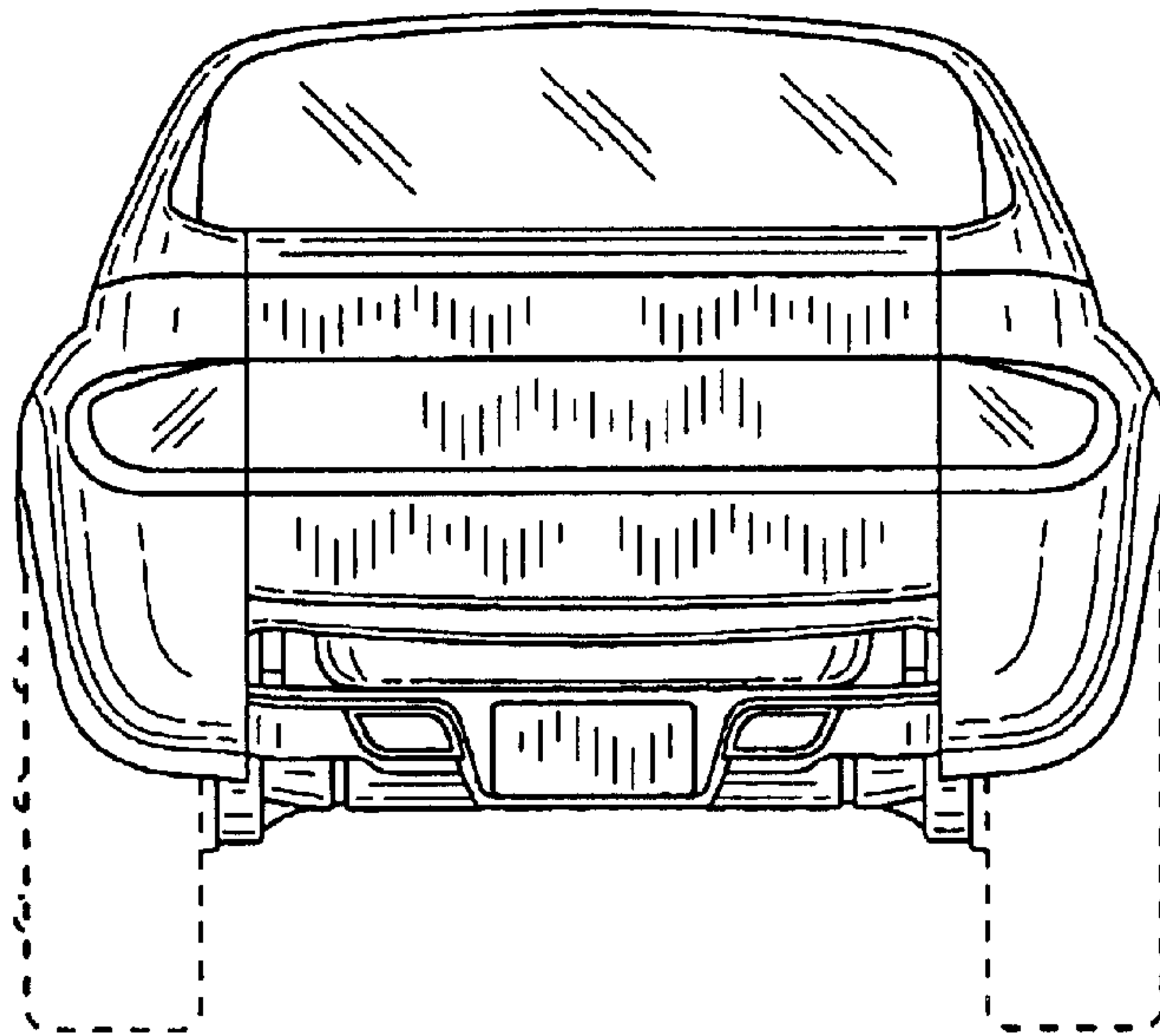
- 4,337,976 A \* 7/1982 Lapine et al. .... 296/39.1
- D450,013 S \* 11/2001 Kato ..... D12/91

**1 Claim, 3 Drawing Sheets**

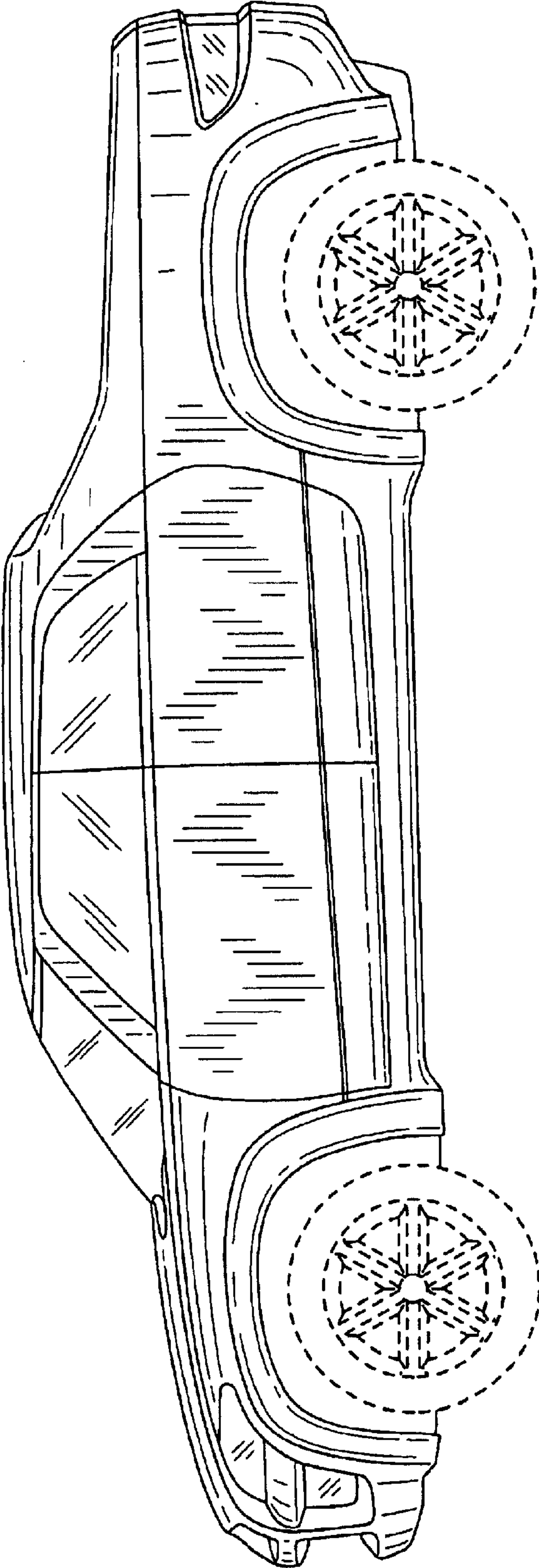




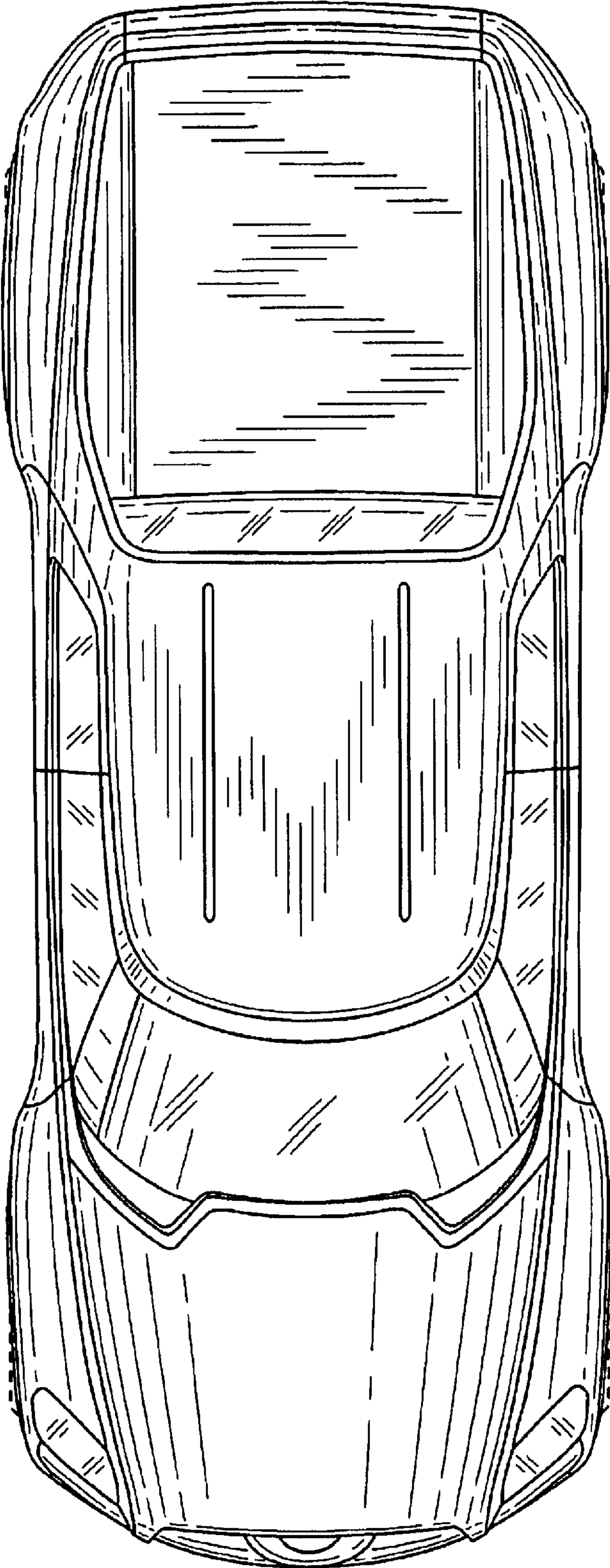
**FIG. 1**



**FIG. 4**



**FIG. 2**



**FIG. 3**