

US00D498124S

(12) **United States Design Patent**
Mitchell

(10) **Patent No.:** **US D498,124 S**

(45) **Date of Patent:** **** Nov. 9, 2004**

(54) **TRIM GUIDE**

(75) Inventor: **Linda Mitchell**, Nashville, TN (US)

(73) Assignee: **Zinsser Co., Inc.**, Somerset, NJ (US)

(**) Term: **14 Years**

(21) Appl. No.: **29/195,690**

(22) Filed: **Dec. 16, 2003**

(51) **LOC (7) Cl.** **08-05**

(52) **U.S. Cl.** **D8/45**

(58) **Field of Search** D8/45, 14, 107;
15/235.3, 236.01

(56) **References Cited**

U.S. PATENT DOCUMENTS

- 1,509,775 A * 9/1924 Phillips 30/125
- 3,774,252 A * 11/1973 Cantales 7/105
- D414,395 S * 9/1999 Panfili D8/107
- 5,956,799 A * 9/1999 Panaccione et al. 15/236.01
- D446,104 S * 8/2001 Chen D8/107
- 6,272,708 B1 * 8/2001 Chen 7/105

- D462,251 S * 9/2002 Collins et al. D8/107
- 6,668,751 B1 * 12/2003 Henke 116/200

* cited by examiner

Primary Examiner—Holly Baynham

(74) *Attorney, Agent, or Firm*—Calfee, Halter & Griswold LLP

(57) **CLAIM**

The ornamental design for a trim guide, as shown and described.

DESCRIPTION

FIG. 1 is a perspective view of a trim guide showing the new design;
 FIG. 2 is a left side view of the trim guide of FIG. 1;
 FIG. 3 is a top view of the trim guide of FIG. 1;
 FIG. 4 is an end view of the trim guide of FIG. 1;
 FIG. 5 is a bottom view of the trim guide of FIG. 1;
 FIG. 6 is an end view of the trim guide of FIG. 1; and,
 FIG. 7 is a right side view of the trim guide of FIG. 1.

1 Claim, 2 Drawing Sheets

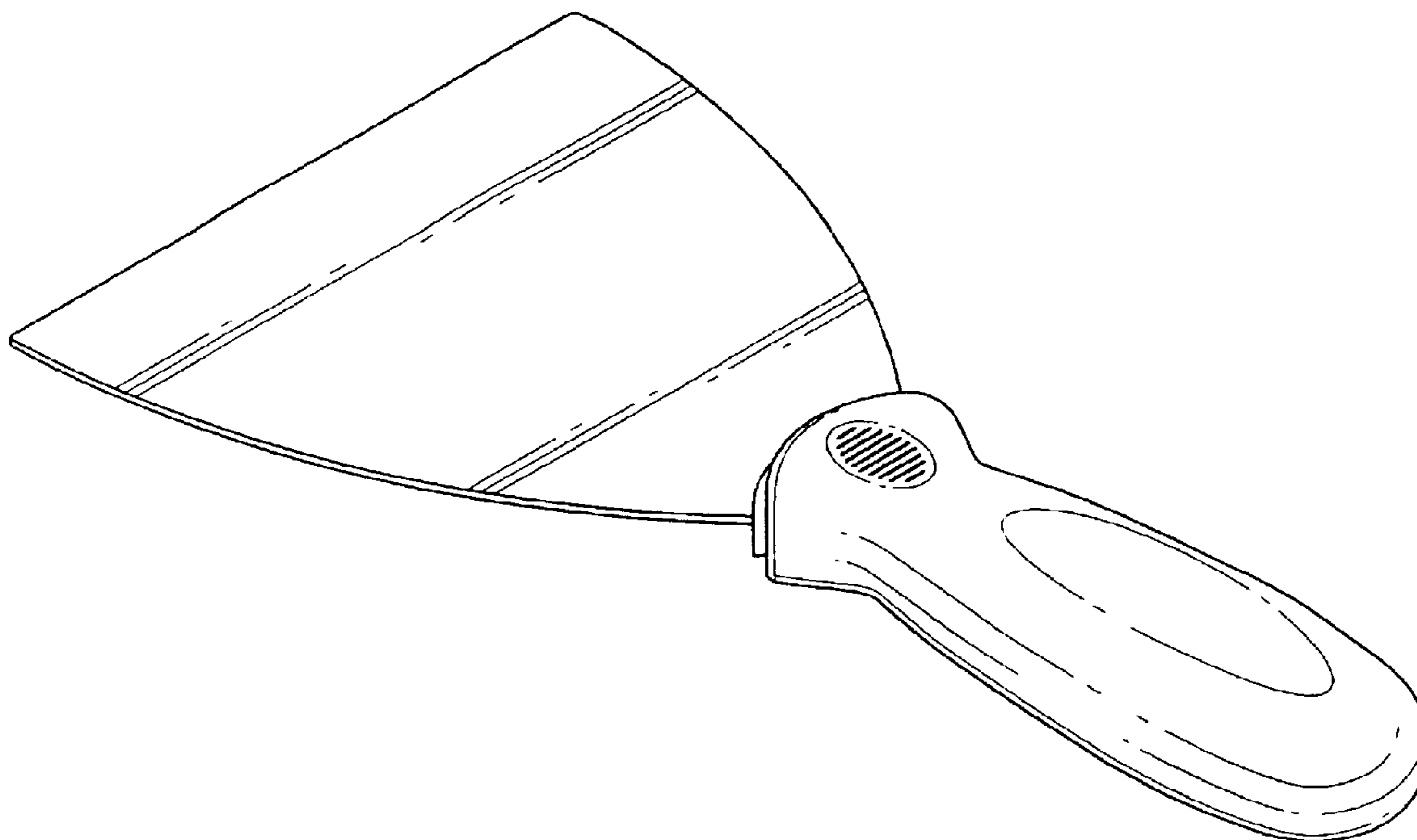

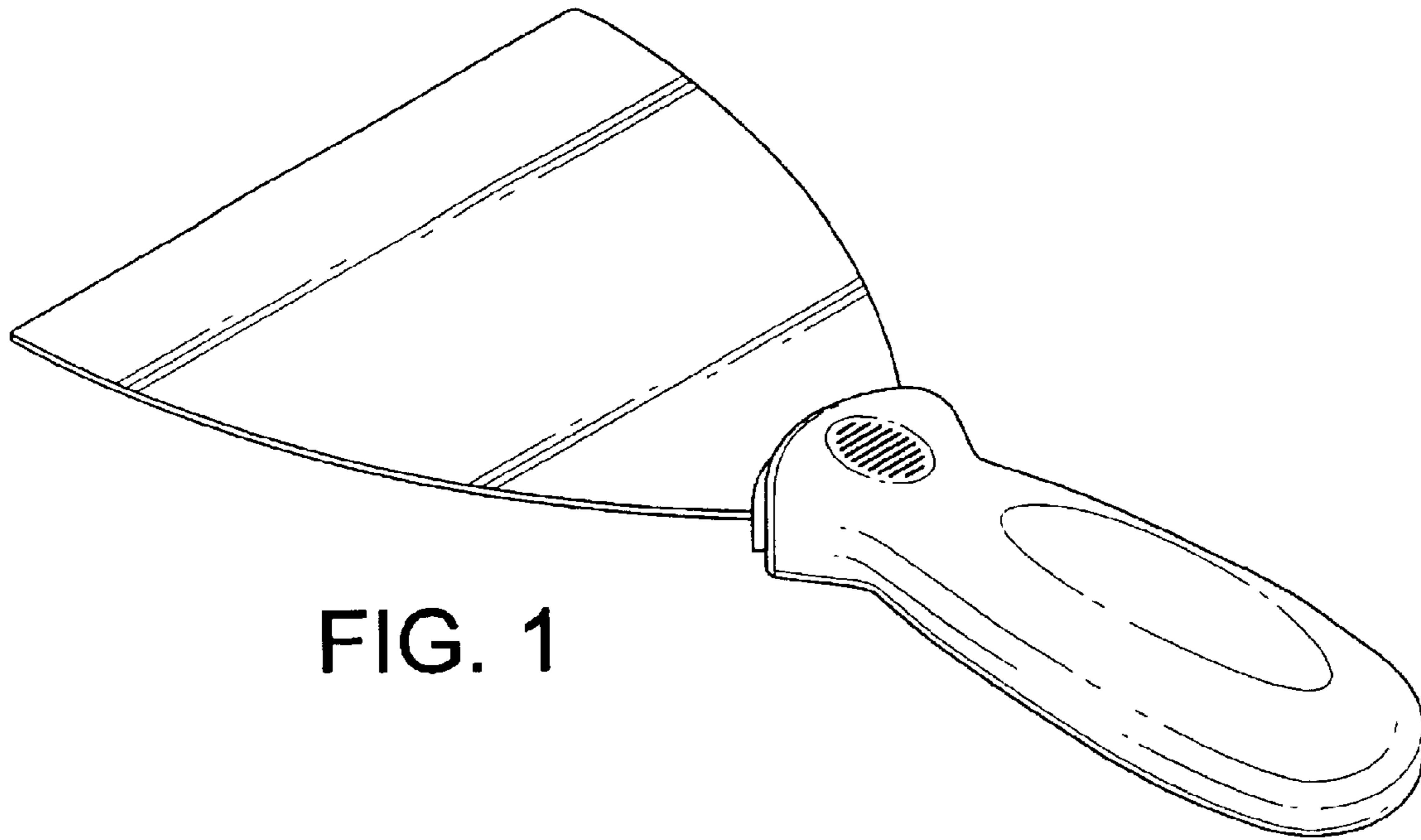

FIG. 1

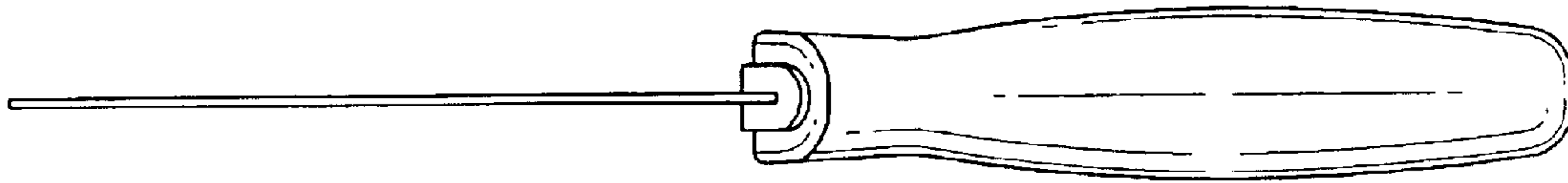

FIG. 2

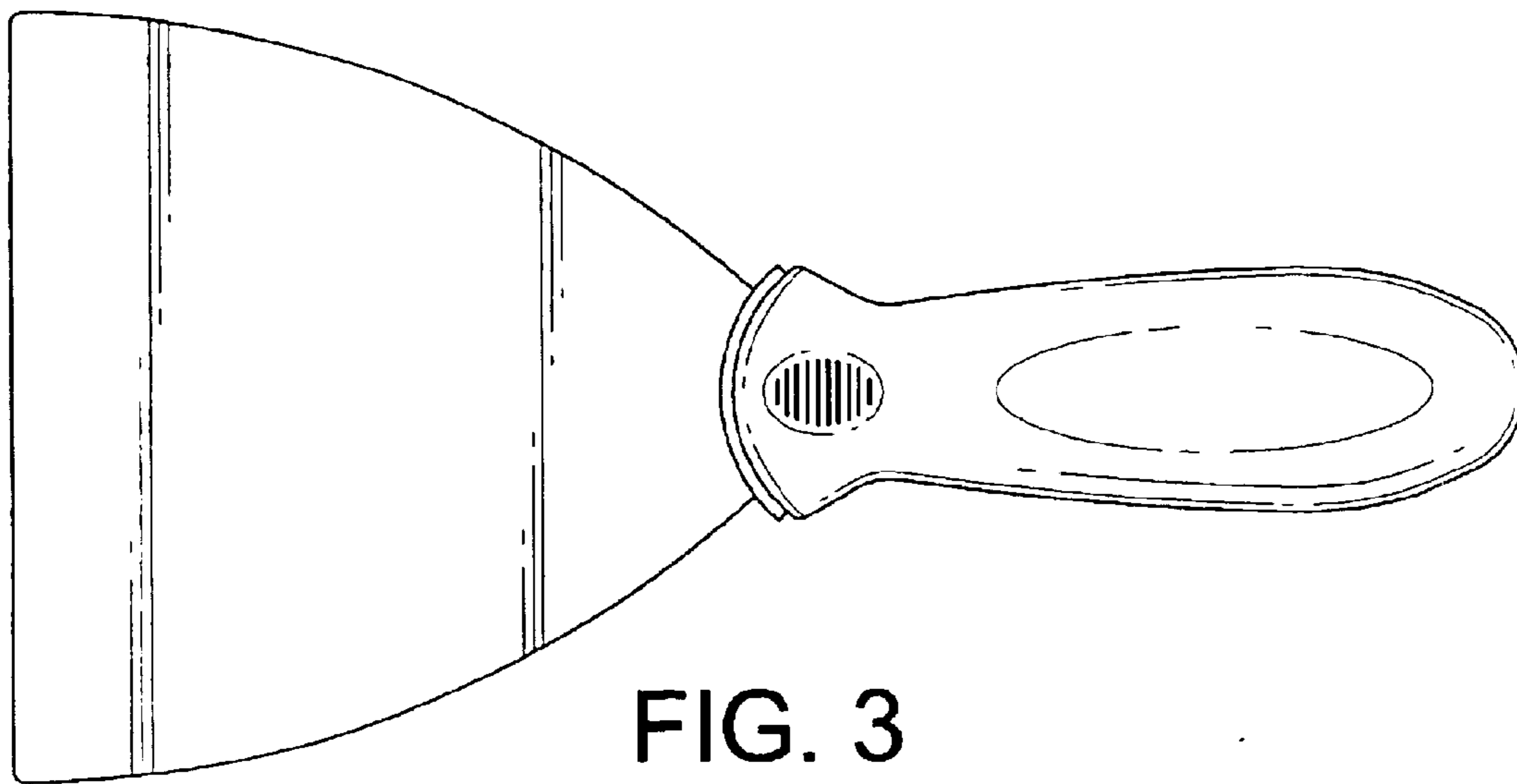

FIG. 3

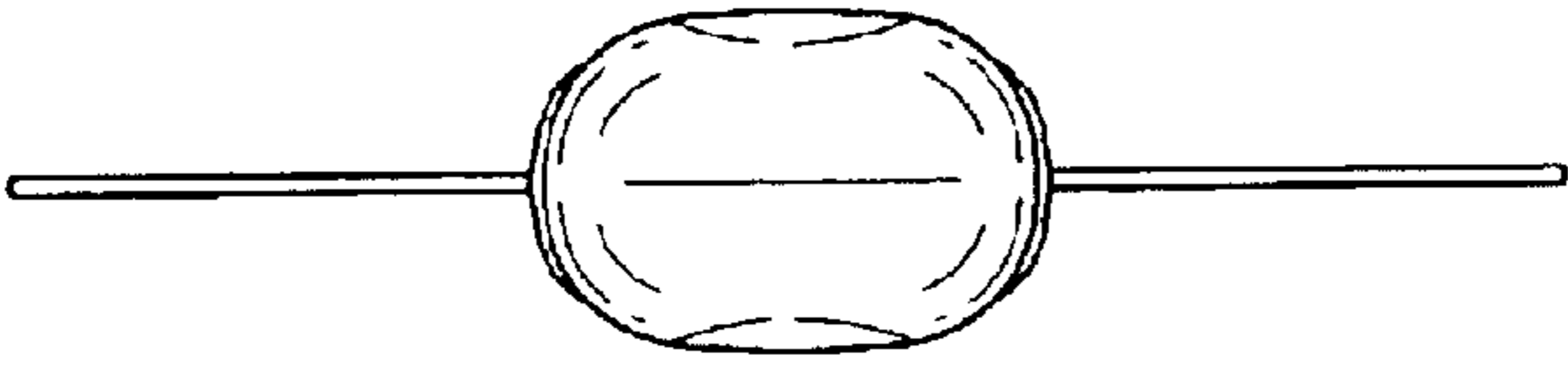

FIG. 6

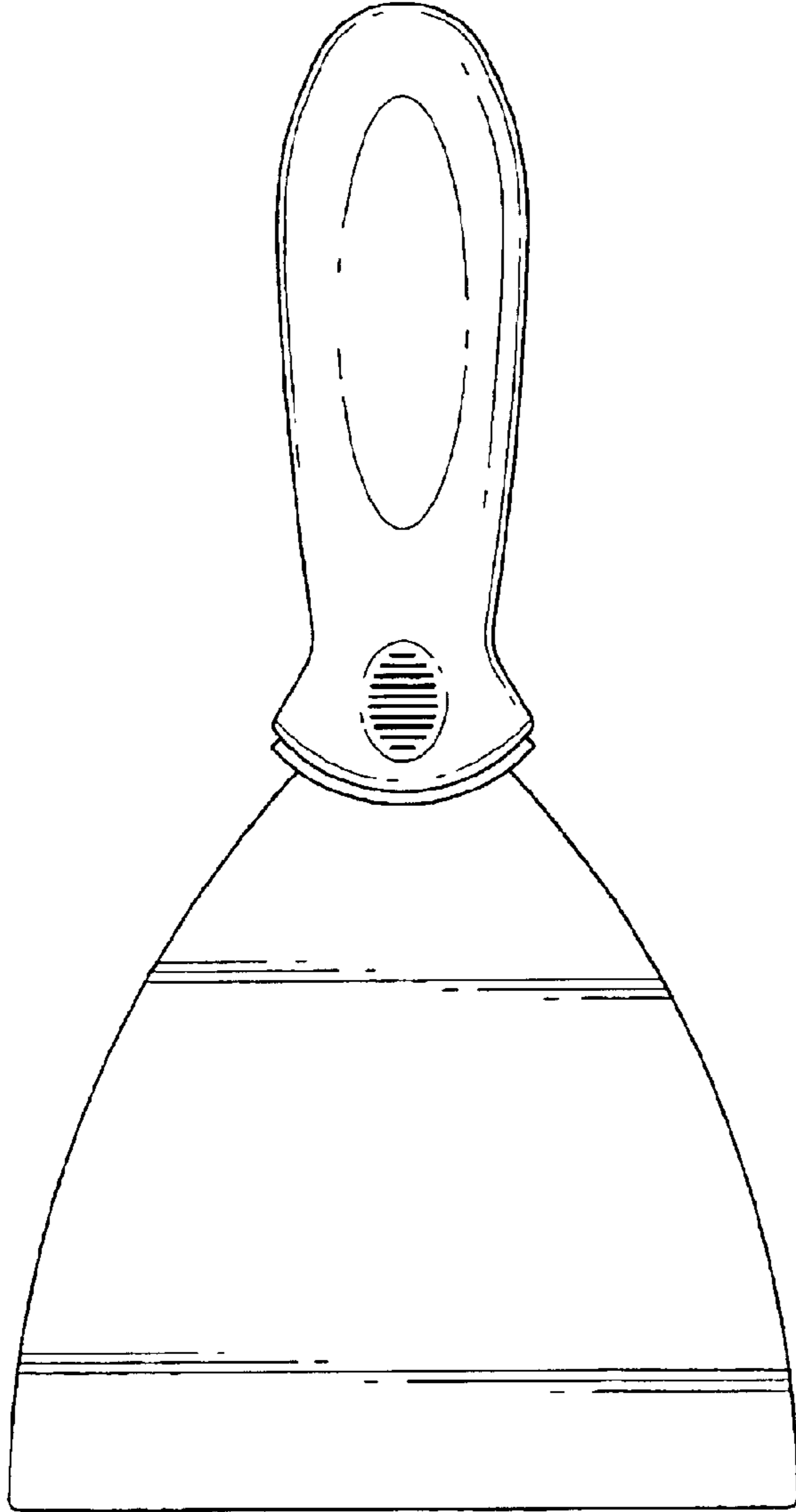

FIG. 5

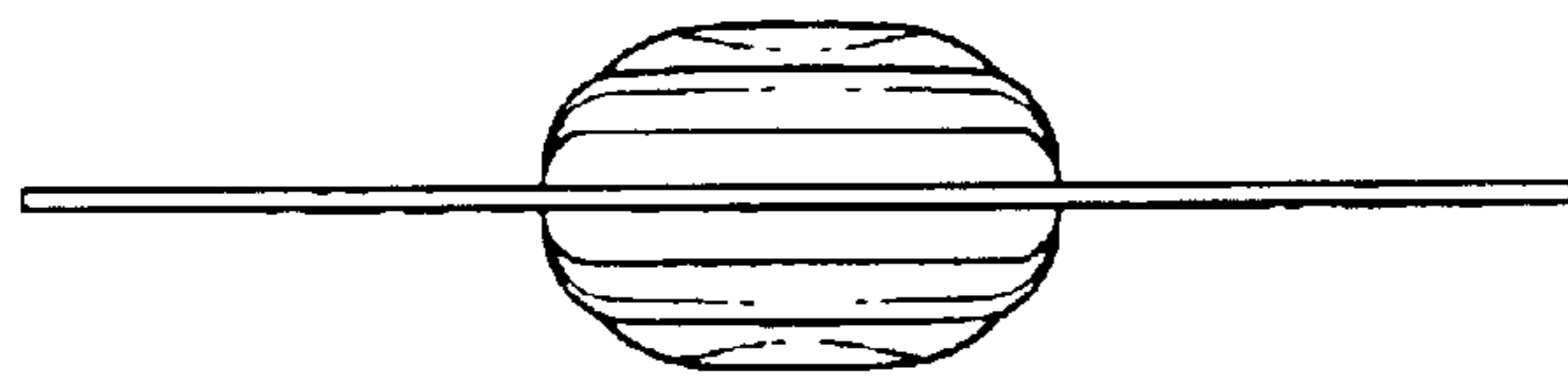

FIG. 4

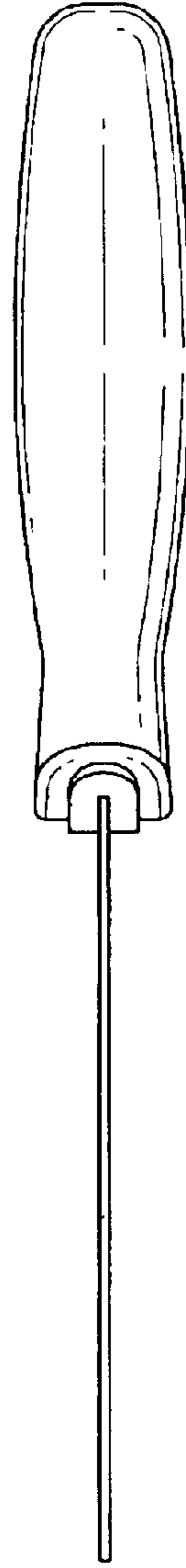

FIG. 7