

US00D497823S1

(12) **United States Design Patent**
Brown

(10) **Patent No.:** **US D497,823 S**

(45) **Date of Patent:** **** Nov. 2, 2004**

(54) **HOLLOW HIGHWAY BARRICADE WITH FRICTION FIT CONNECTION**

(76) **Inventor:** **James C. Brown**, 2121 Skyhawk Dr., Fort Wayne, IN (US) 46815

(**) **Term:** **14 Years**

(21) **Appl. No.:** **29/196,252**

(22) **Filed:** **Dec. 23, 2003**

(51) **LOC (7) Cl.** **10-05**

(52) **U.S. Cl.** **D10/109**

(58) **Field of Search** D10/109, 113;
D25/39, 44; 256/1, 13.1; 404/6, 9; 52/730.4,
730.5

(56) **References Cited**

U.S. PATENT DOCUMENTS

2,279,942	A	*	4/1942	Hausherr	256/13.1
4,946,306	A	*	8/1990	Yodock	404/6
5,104,254	A	*	4/1992	Durand	404/6
5,123,773	A	*	6/1992	Yodock	404/6
D341,098	S	*	11/1993	Yodock	D10/109
5,531,540	A	*	7/1996	Wasserstrom et al.	404/6
5,605,413	A		2/1997	Brown	404/6

D391,513	S	*	3/1998	Brown	D10/113
5,821,140	A	*	10/1998	Jost et al.	438/241
5,988,934	A	*	11/1999	Wasserstrom	404/6
6,164,865	A	*	12/2000	McCallum	404/6
6,666,613	B2	*	12/2003	Wu	403/299

* cited by examiner

Primary Examiner—Nelson C. Holtje

(57) **CLAIM**

The ornamental design for a hollow highway barricade with friction fit connection, as shown and described.

DESCRIPTION

FIG. 1 Shows right front isometric view of with water fill cap on top, an outlet to drain the water, and the friction fit connection.

FIG. 2 Shows front view of claim 1 thereof;

FIG. 3 Shows top view of claim 1 thereof;

FIG. 4 Shows back view of claim 1 thereof;

FIG. 5 Shows bottom view of claim 1 thereof;

FIG. 6 Shows left side view of claim 1 thereof;

FIG. 7 Shows right side view of claim 1 thereof; and,

FIG. 8 Shows left front isometric view of claim 1 thereof.

1 Claim, 3 Drawing Sheets

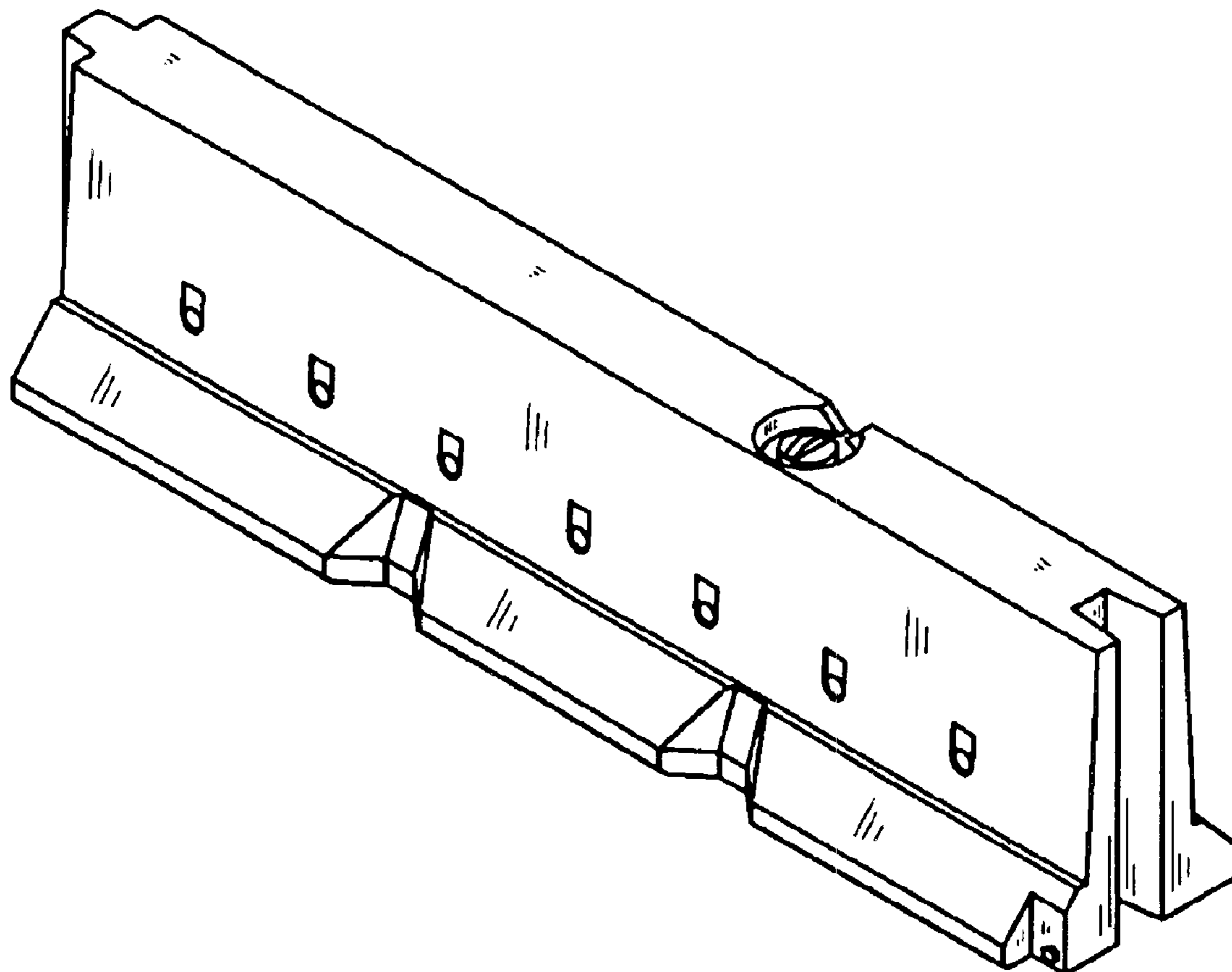

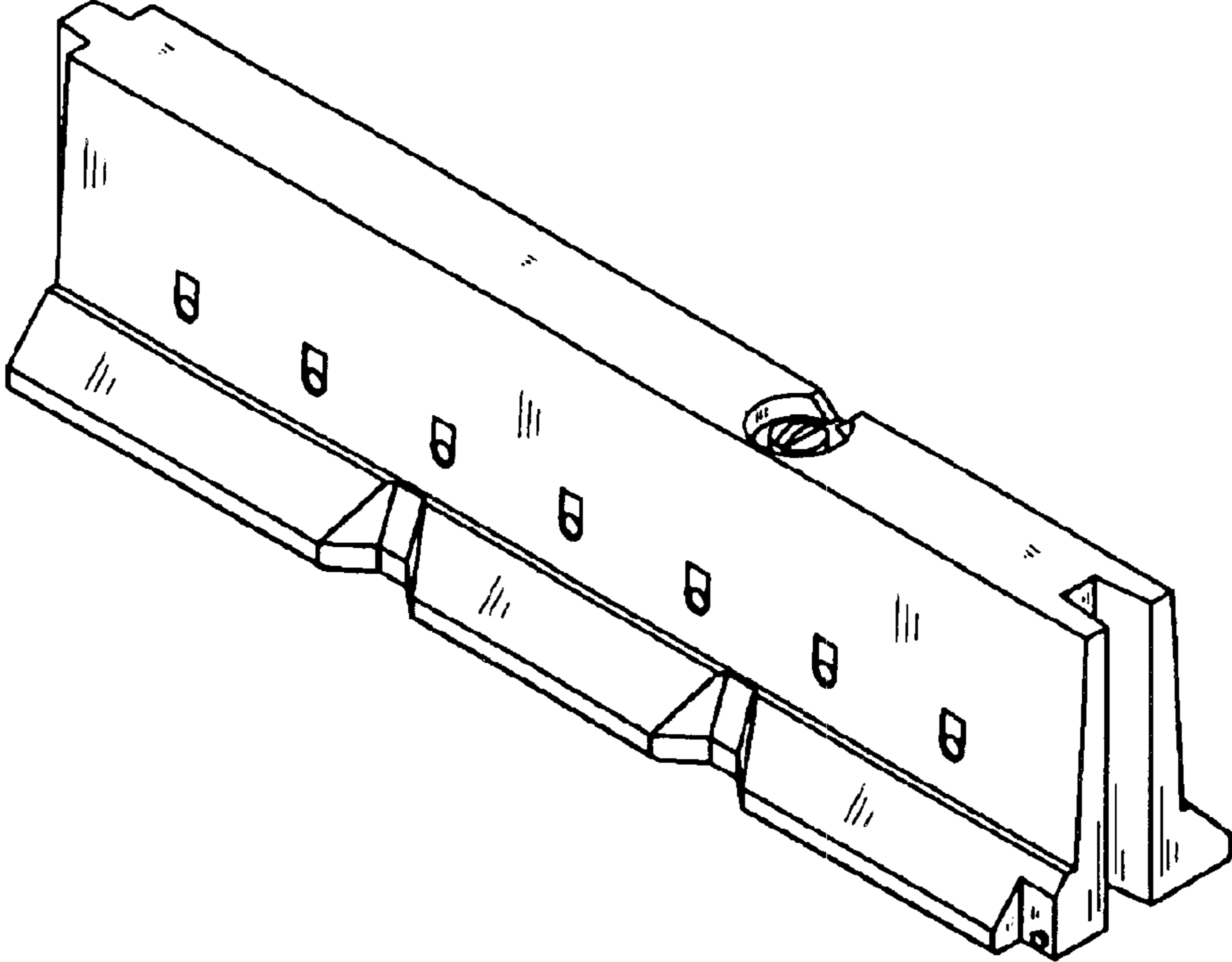

FIG. 1

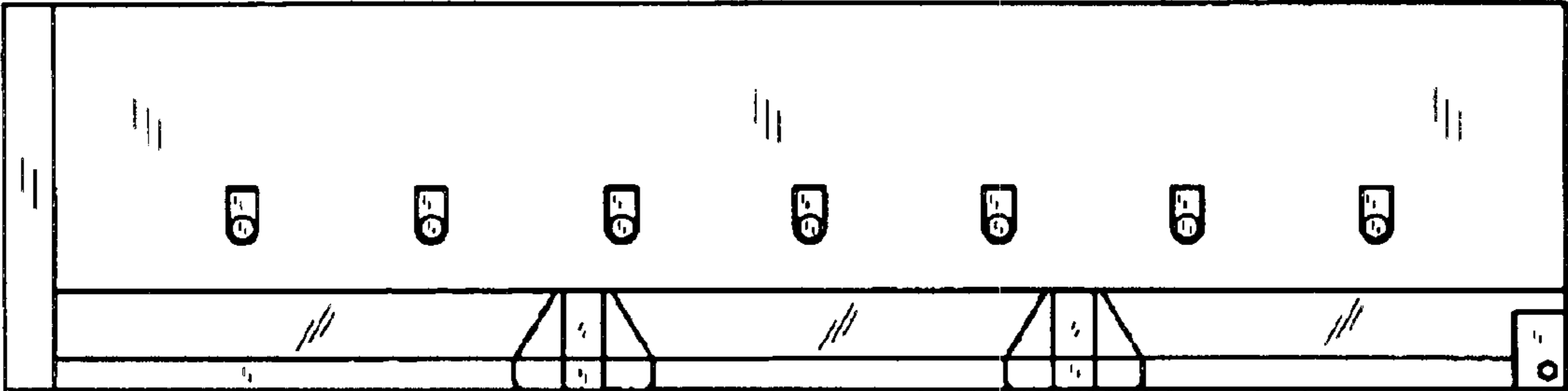

FIG. 2

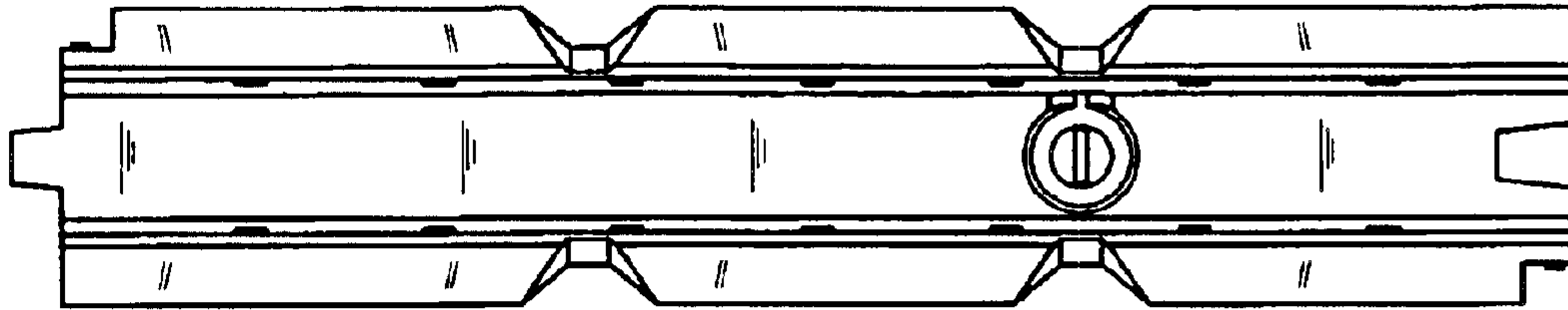

FIG. 3

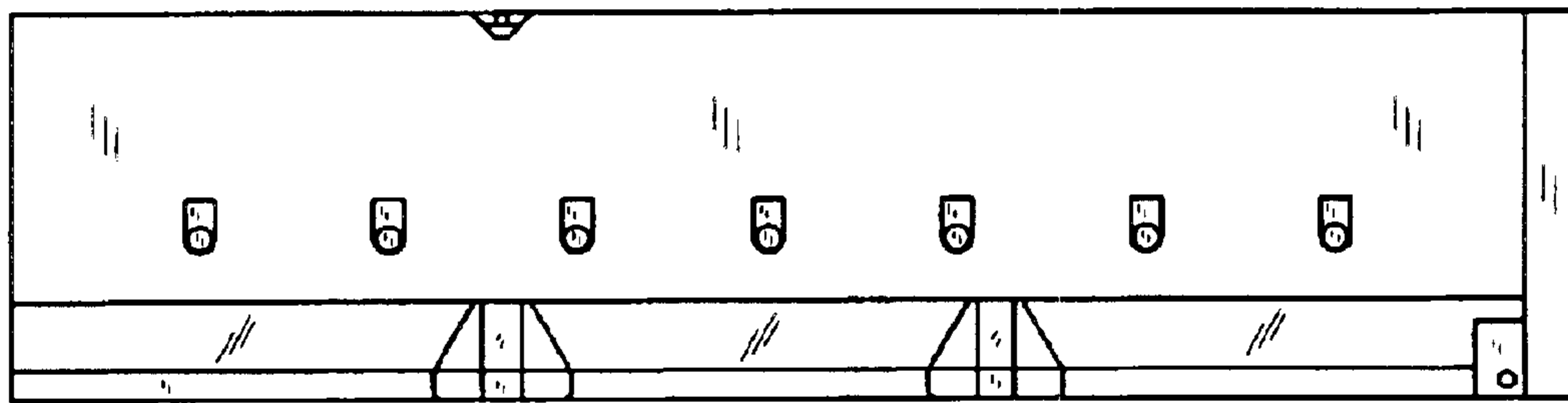

FIG. 4

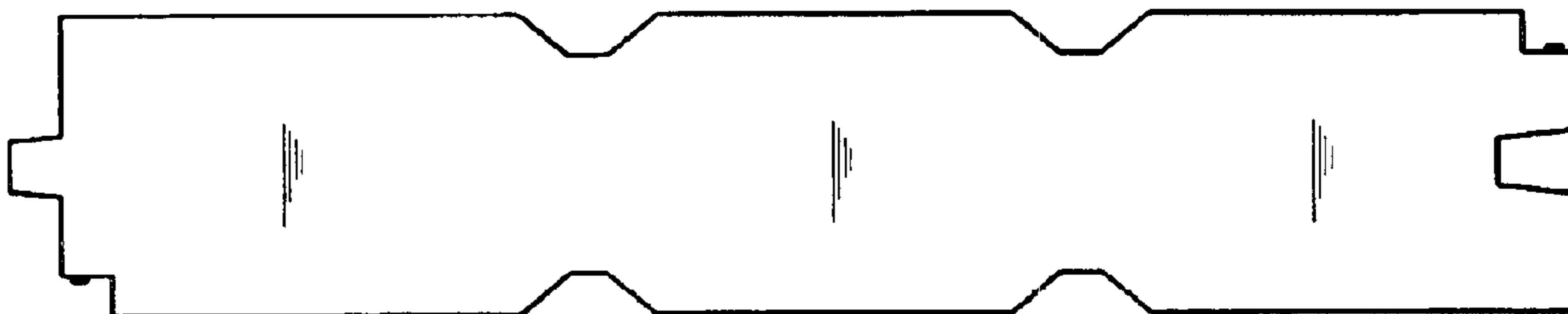

FIG. 5

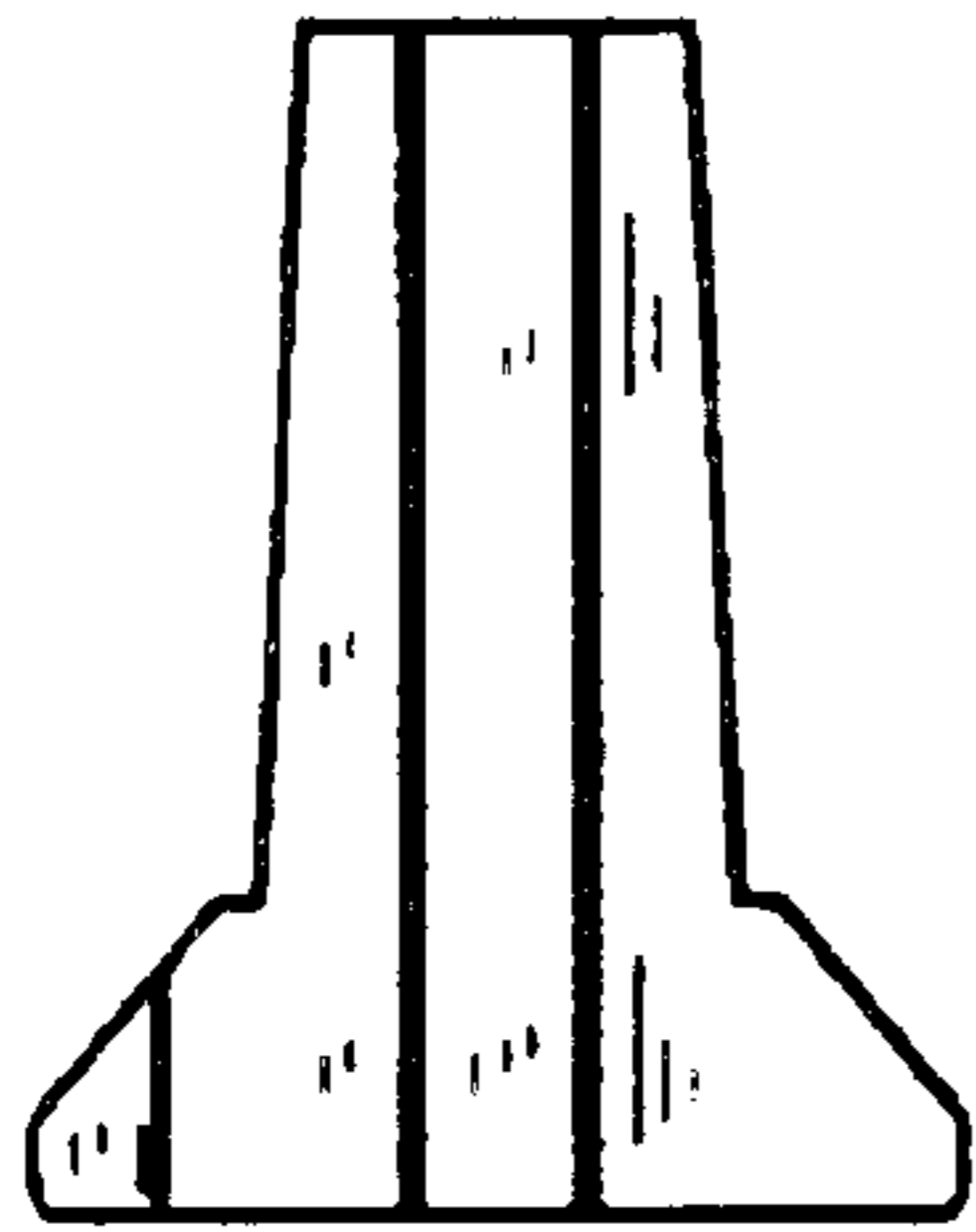

FIG. 6

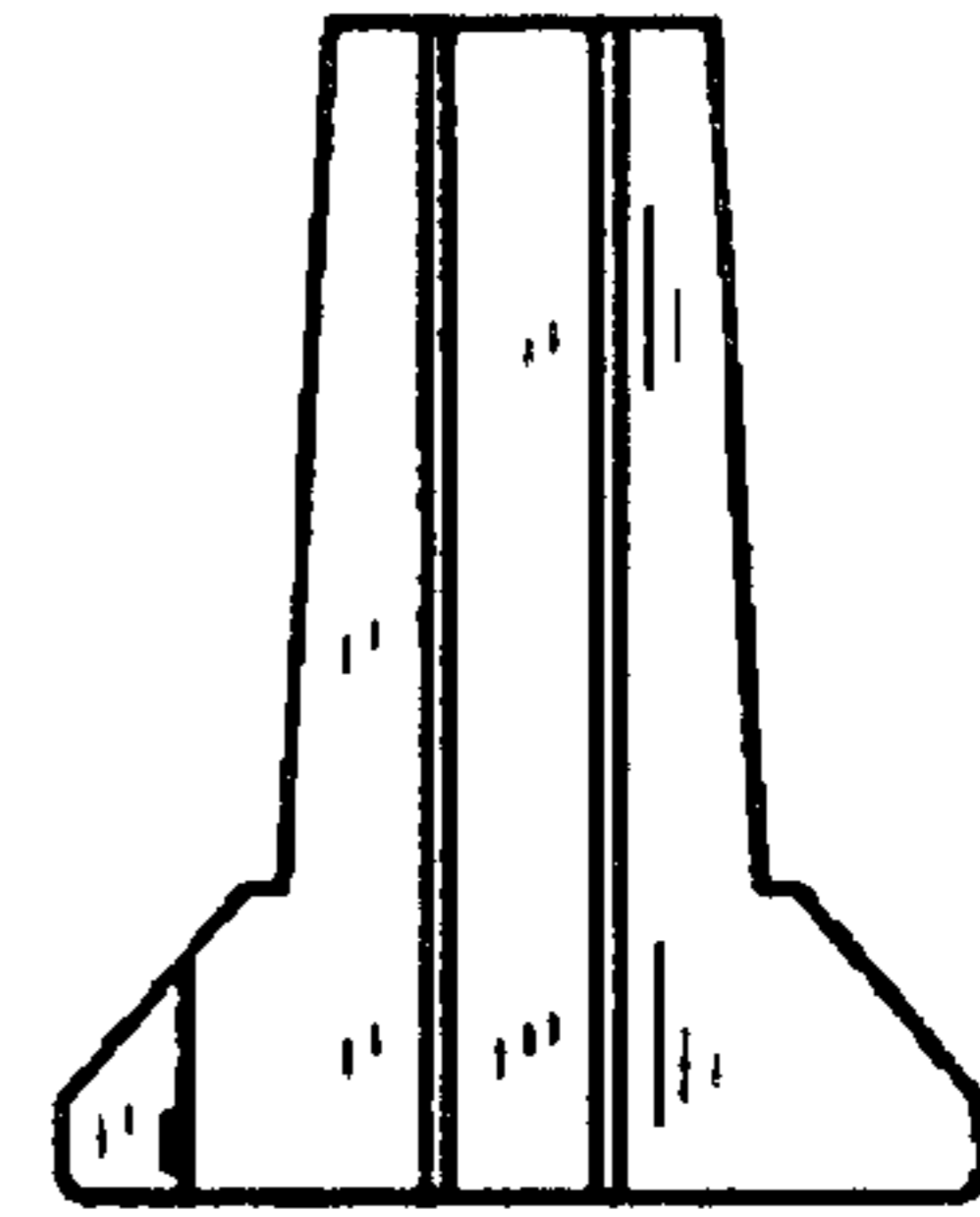

FIG. 7

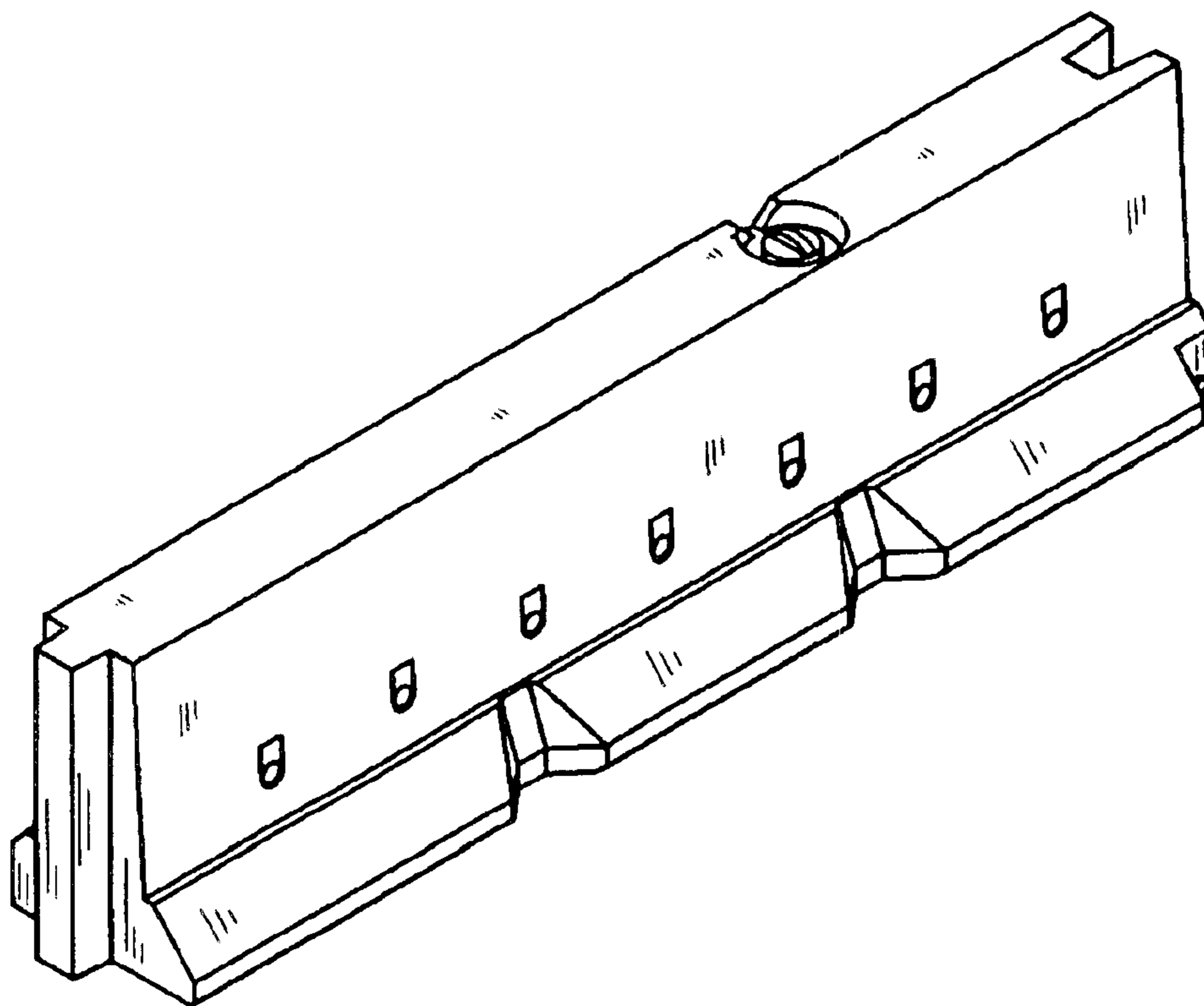

FIG. 8