

US00D497619S1

(12) **United States Design Patent**  
**Reitsma**

(10) **Patent No.:** **US D497,619 S**  
(45) **Date of Patent:** **\*\* Oct. 26, 2004**

(54) **COMBINED AIR INTAKE HOSE AND FILTER**

(76) **Inventor:** **Bert Reitsma**, 943 Goldenrod St., Escondido, CA (US) 92027-1711

(\*\*) **Term:** **14 Years**

(21) **Appl. No.:** **29/192,929**

(22) **Filed:** **Oct. 30, 2003**

(51) **LOC (7) Cl.** ..... **15-01**

(52) **U.S. Cl.** ..... **D15/5**

(58) **Field of Search** ..... D15/1, 5-9; 123/198 E, 123/308, 184.34, 184.53-184.56; 181/227-229, 282; 60/299, 302; 96/381-387; 55/502-507, 385.3

(56) **References Cited**

**U.S. PATENT DOCUMENTS**

D405,095 S	*	2/1999	Wada	.....	D15/5
D455,438 S	*	4/2002	Hall	.....	D15/5
6,705,272 B2	*	3/2004	Leipelt et al.	.....	123/198 E
6,726,738 B1	*	4/2004	Walker, Jr.	.....	55/385.3

\* cited by examiner

*Primary Examiner*—Melody N. Brown

(74) *Attorney, Agent, or Firm*—Willie Krawitz

(57) **CLAIM**

The ornamental design for a combined air intake hose and filter, as shown and described.

**DESCRIPTION**

FIG. 1 is a perspective view of air intake hose and filter at the air intake, for expansion of cool, ambient air into an air filter holder, while by-passing the engine, showing my design;

FIG. 2 is a right side elevation view thereof;

FIG. 3 is a rear elevation view thereof;

FIG. 4 is a top plan view thereof;

FIG. 5 is a bottom plan view thereof;

FIG. 6 is a left side elevation view thereof;

FIG. 7 is a front elevation view thereof;

FIG. 8 is a perspective view of a second embodiment of this invention, and similar to that of FIG. 1;

FIG. 9 is a front elevation view of FIG. 8, and similar to that of FIG. 7; and,

FIG. 10 is a top plan view of FIG. 8, and similar to that of FIG. 4.

The broken lines shown throughout the drawing are for illustrative purposes only and form no part of the claimed design.

**1 Claim, 3 Drawing Sheets**

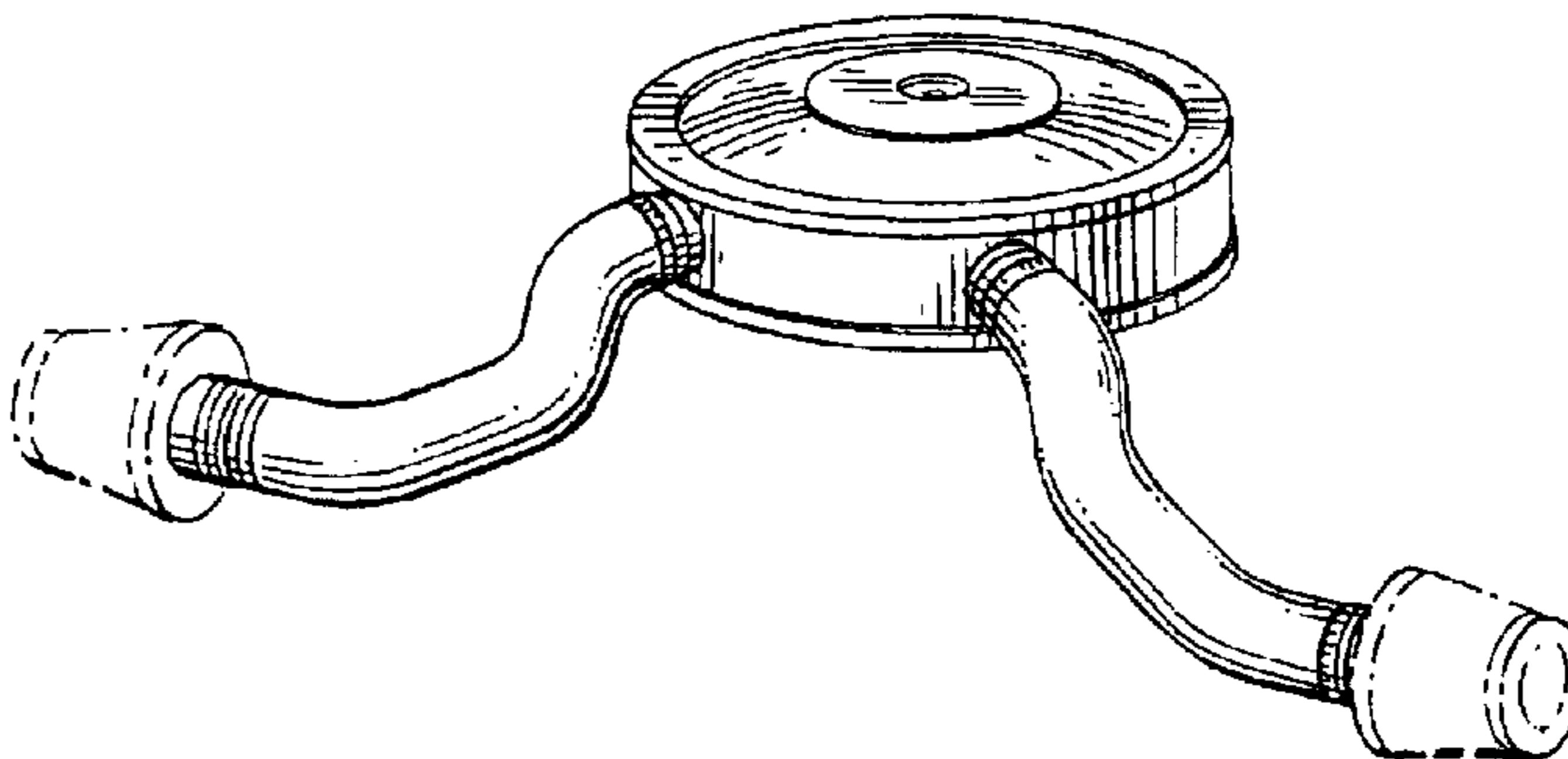
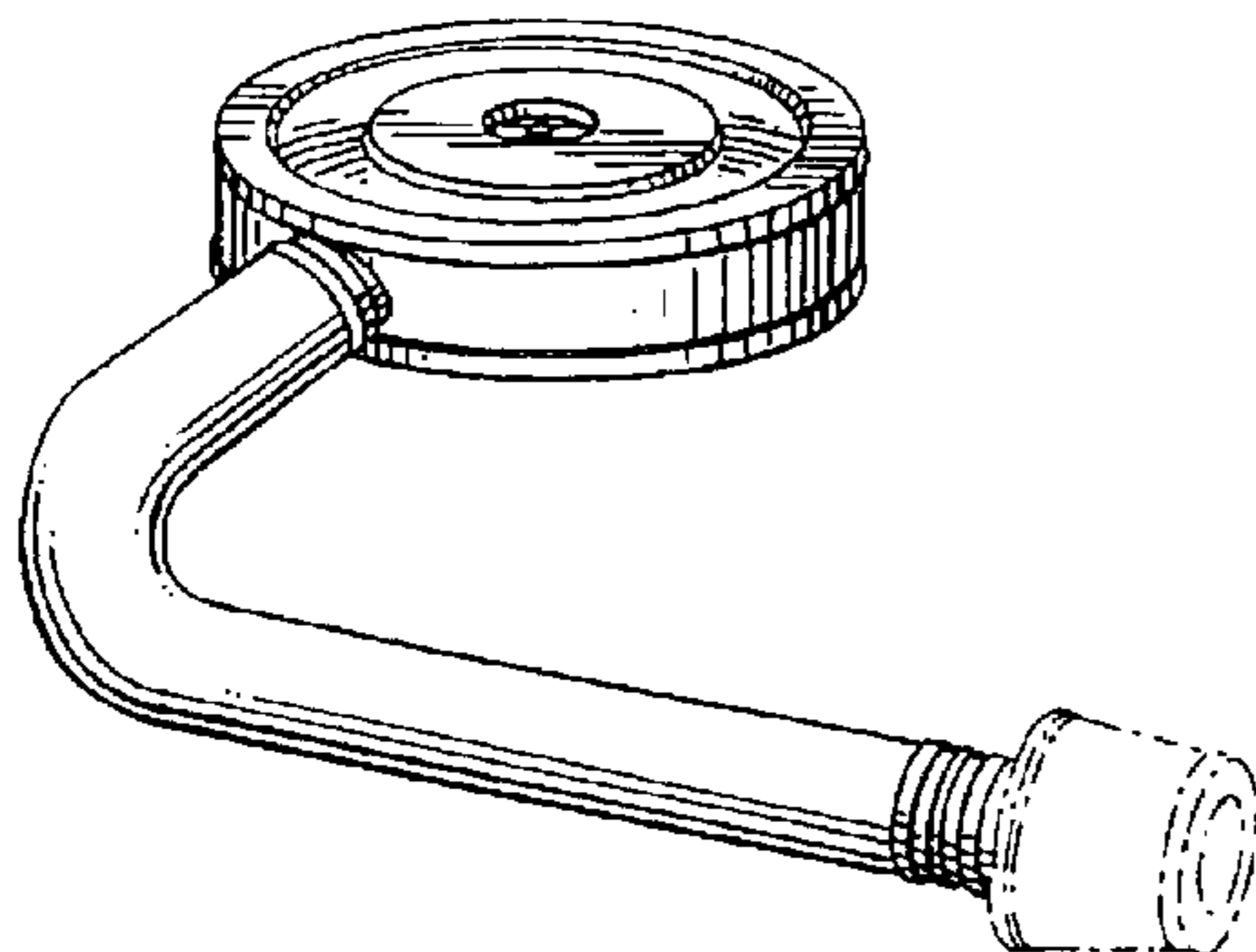

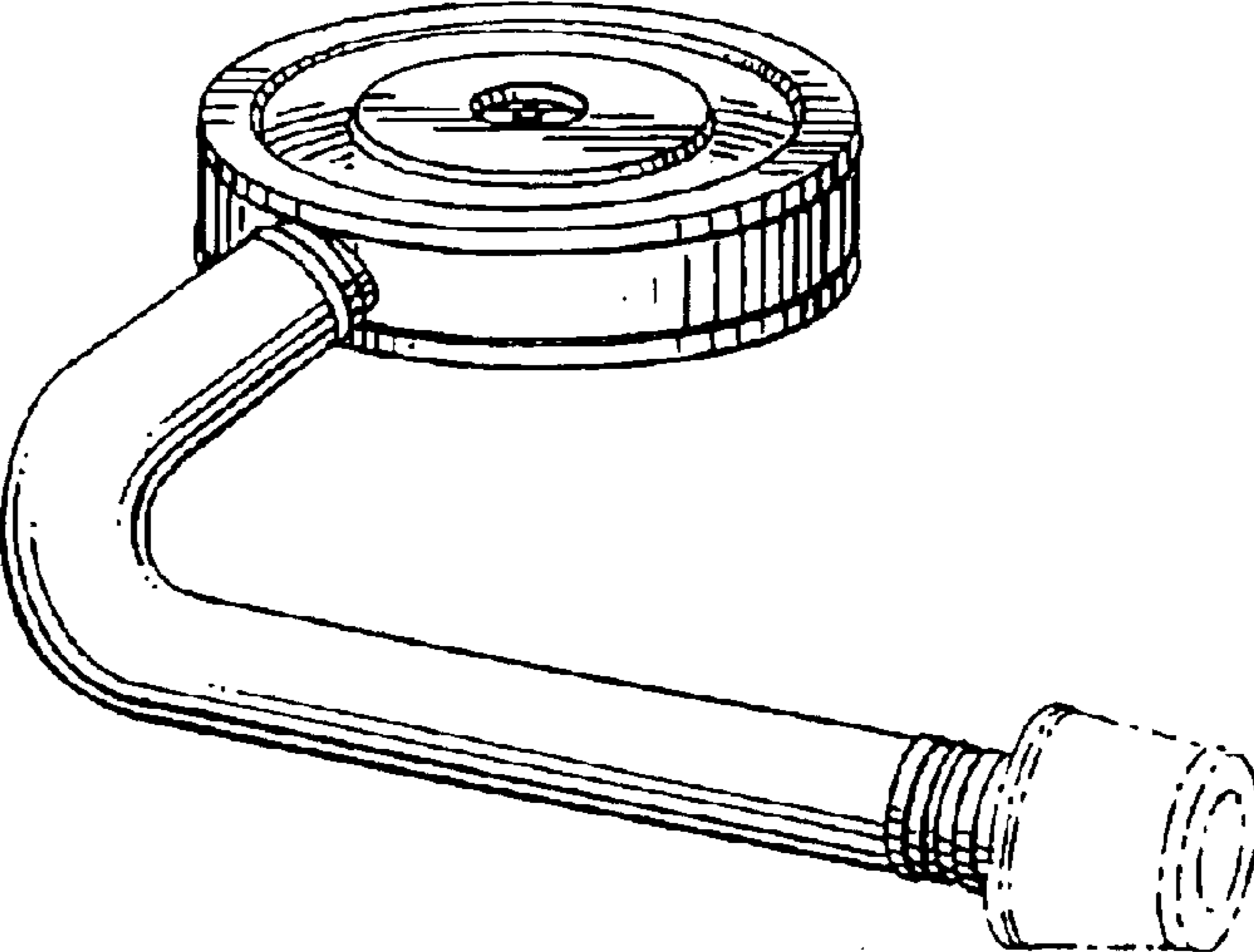

FIG. 1

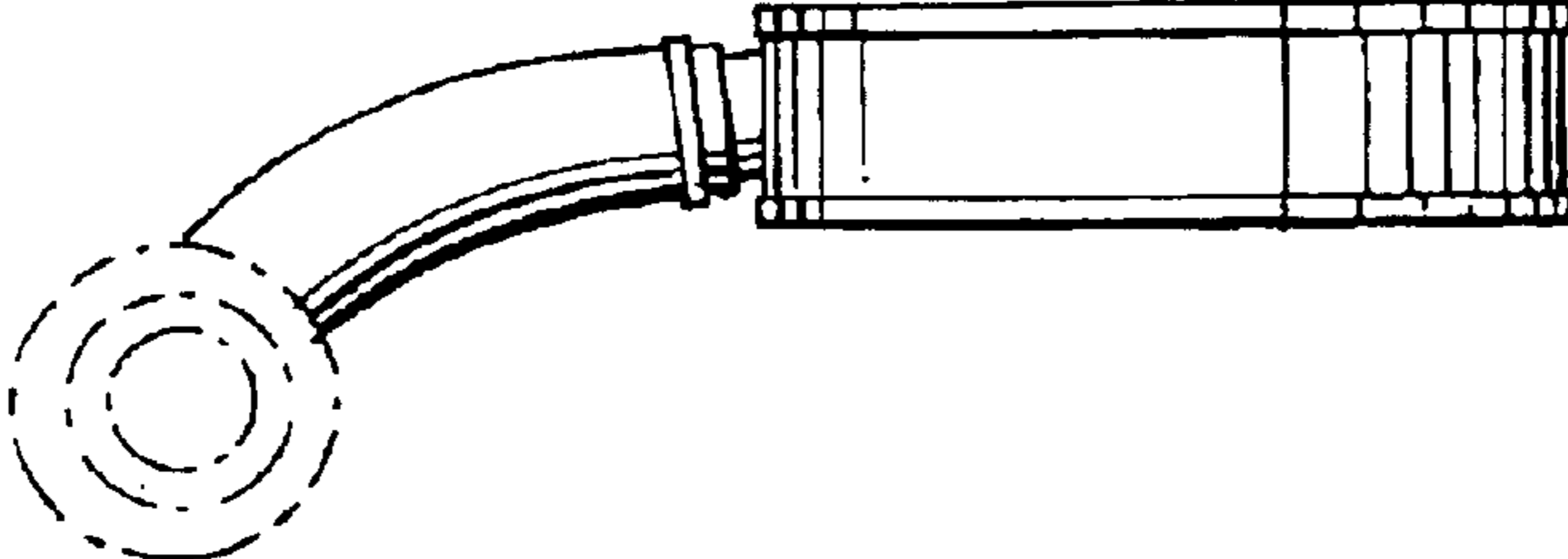

FIG. 2

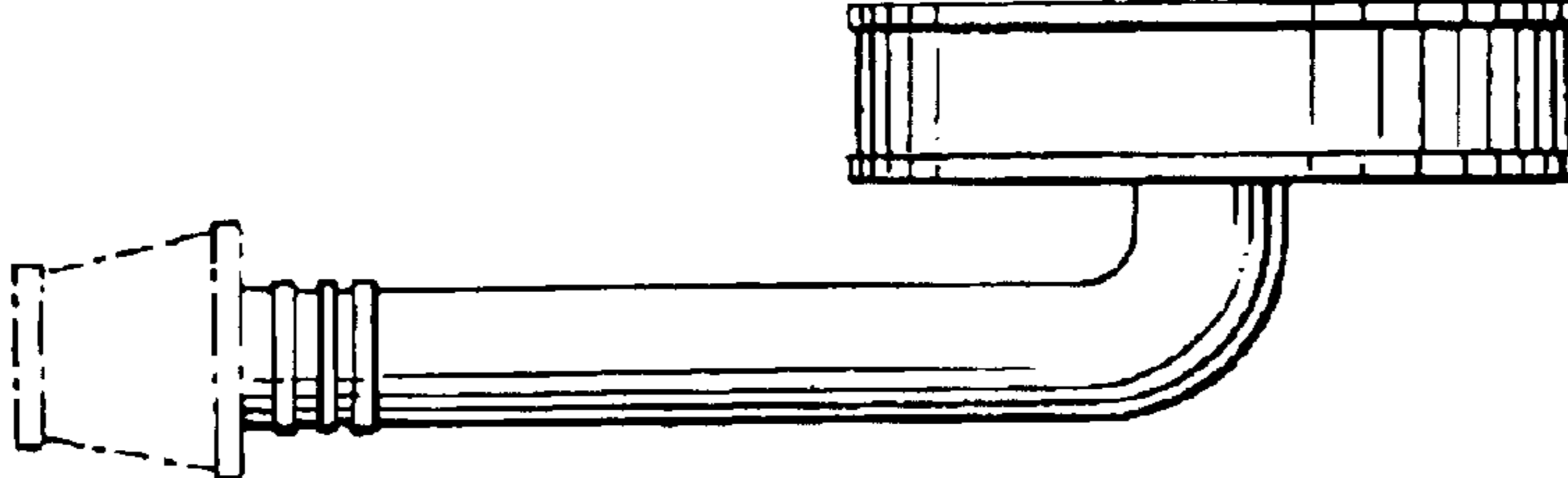

FIG. 3

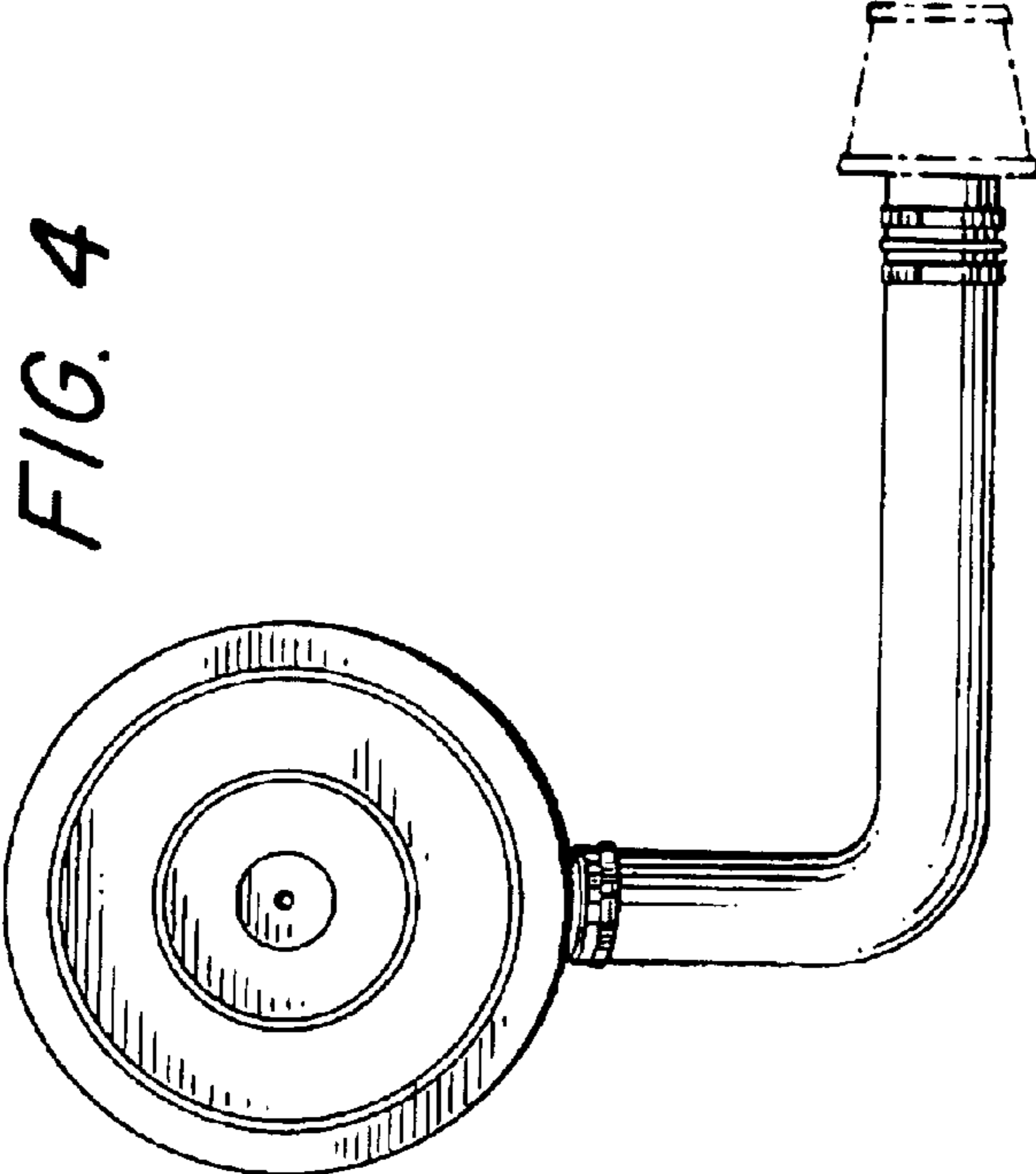

FIG. 4

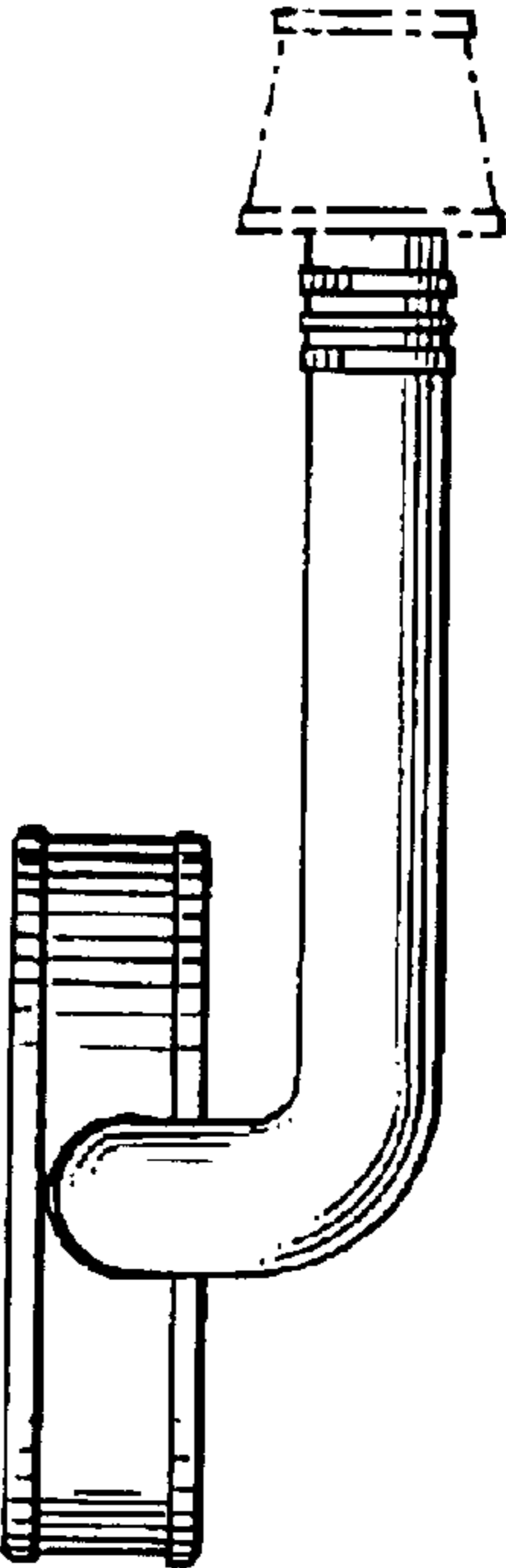

FIG. 7

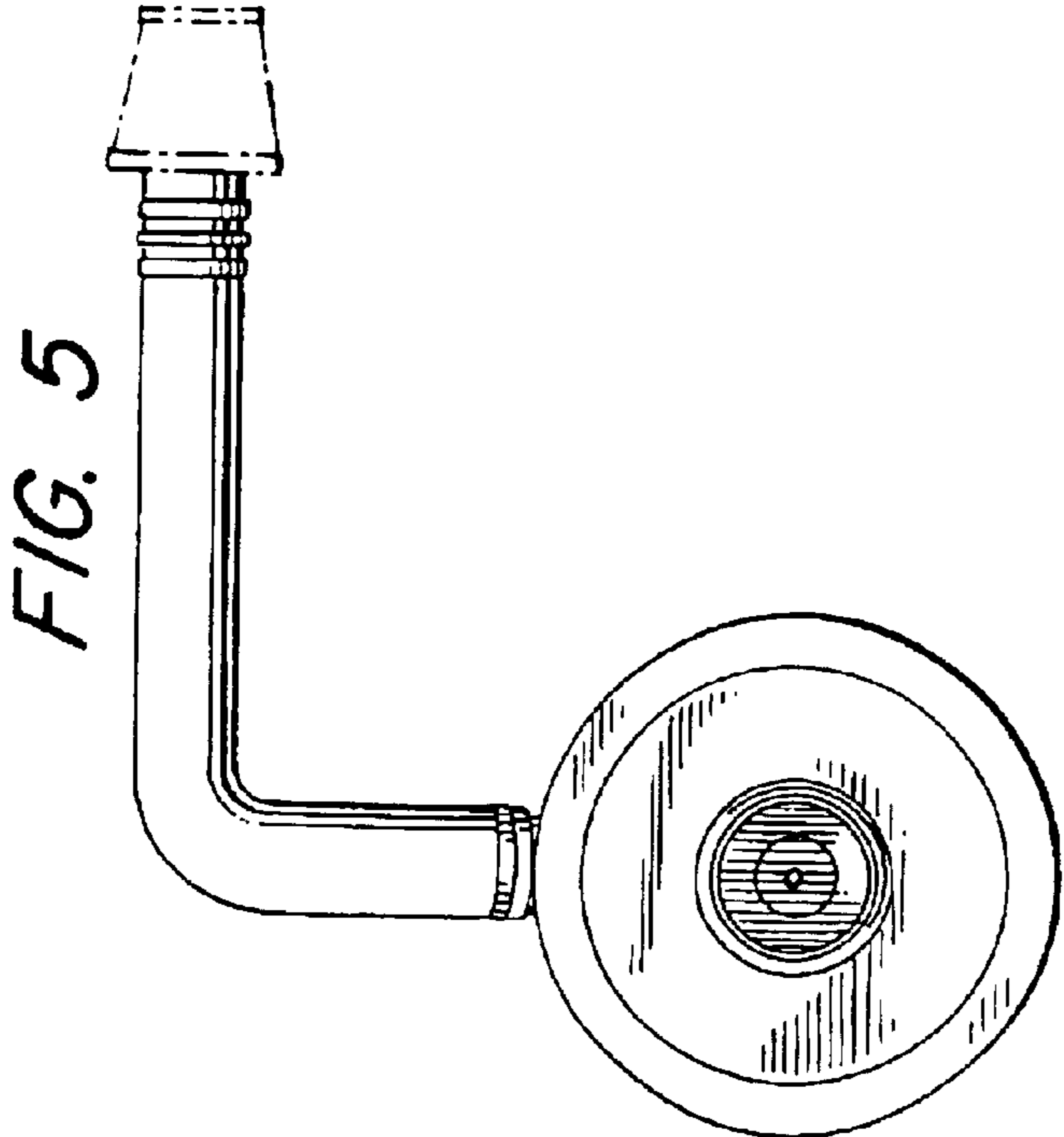

FIG. 5

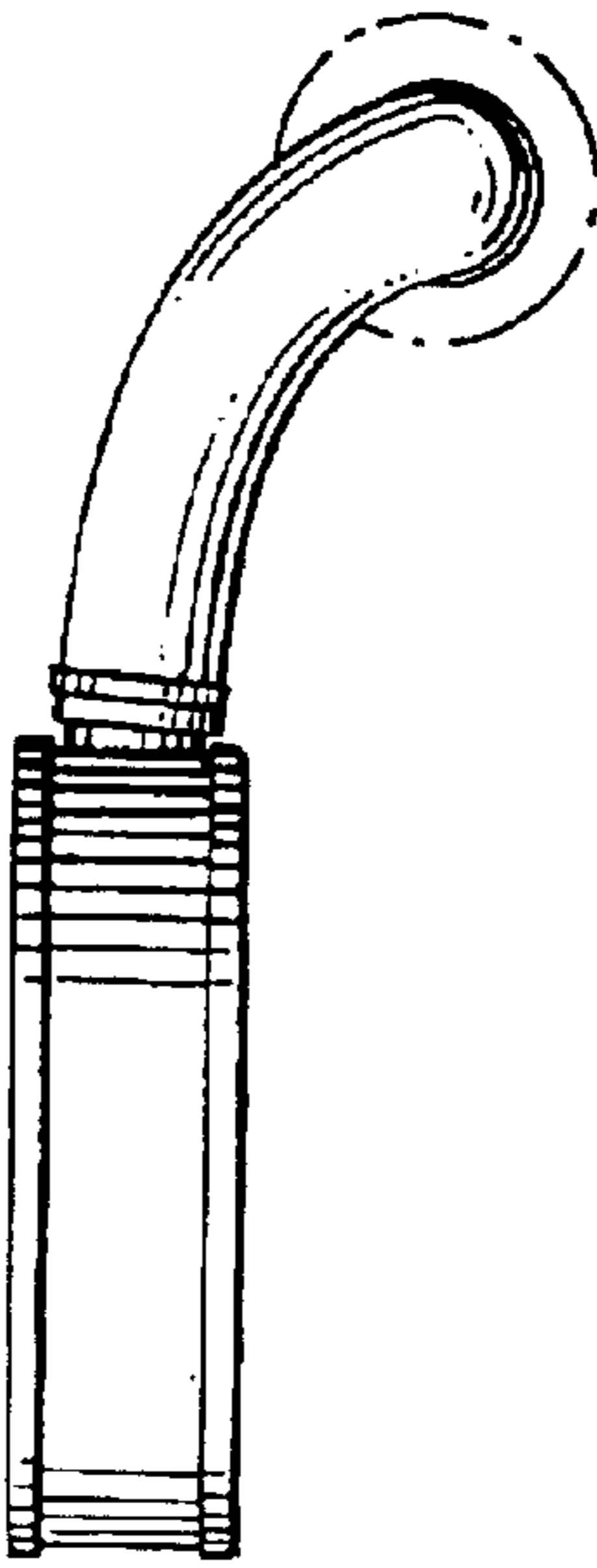
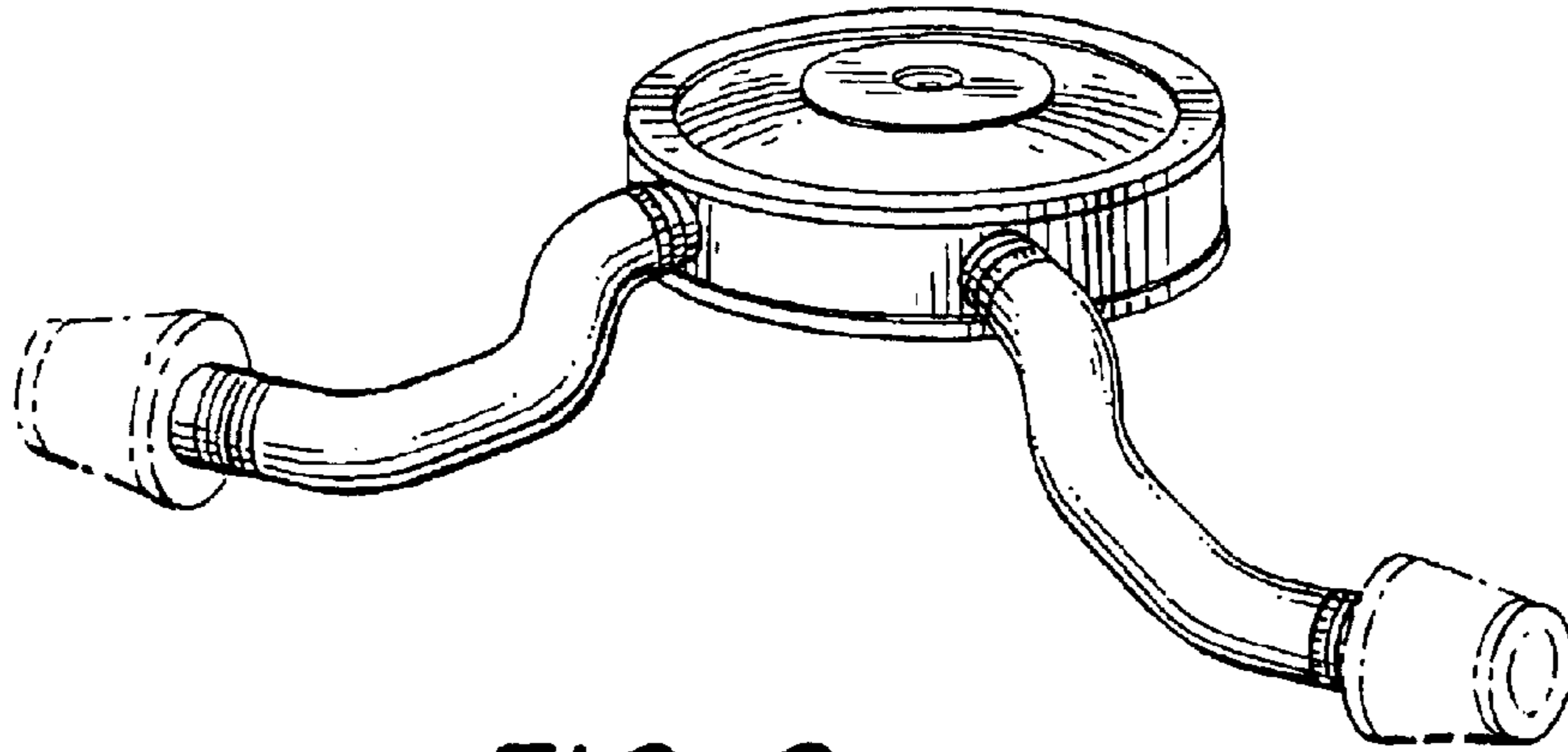
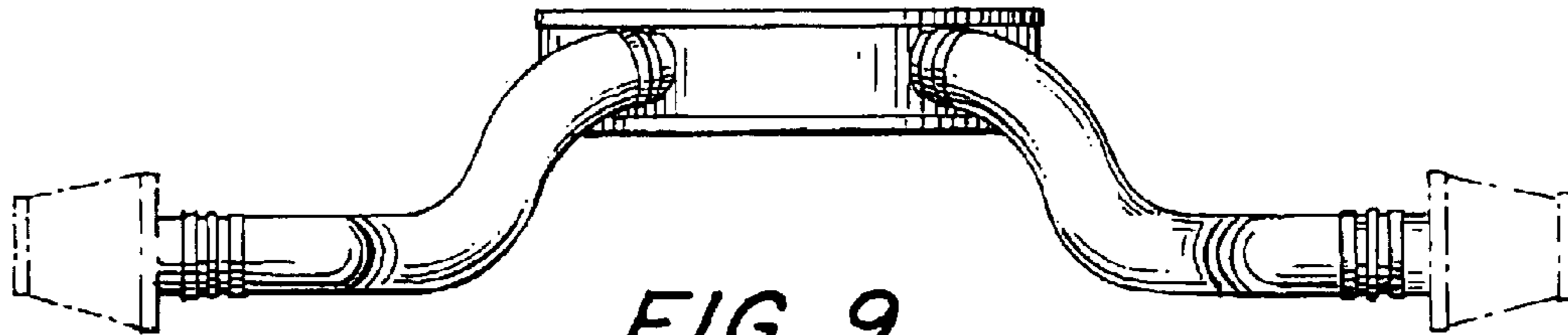

FIG. 6



*FIG. 8*



*FIG. 9*

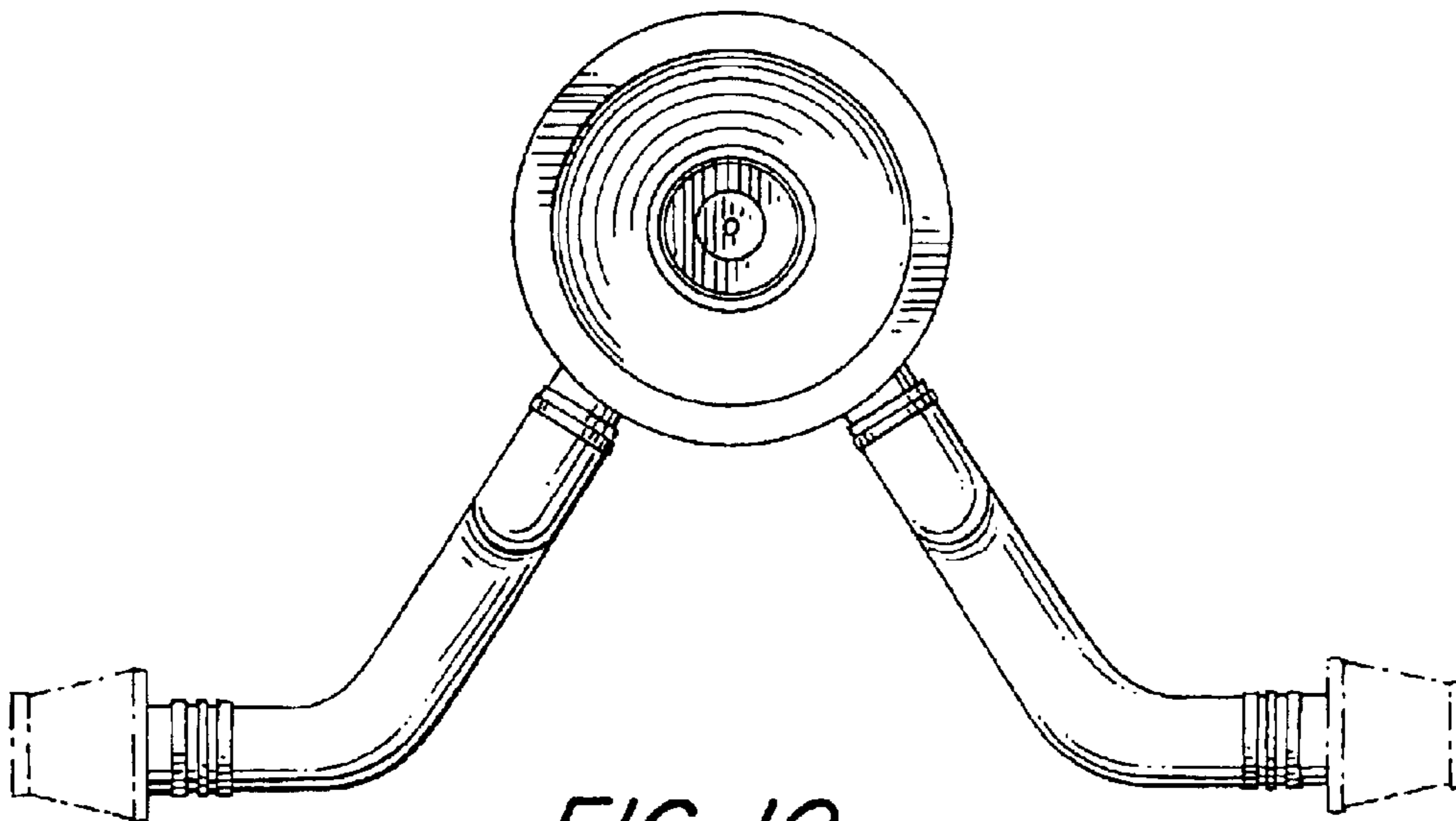

*FIG. 10*