

US00D497582S1

(12) **United States Design Patent**
James

(10) **Patent No.:** **US D497,582 S**

(45) **Date of Patent:** **** Oct. 26, 2004**

(54) **MOTORCYCLE HANDLE BAR**

(75) **Inventor:** **Jesse G. James**, Surfside, CA (US)

(73) **Assignee:** **Honda Motor Co., Ltd.**, Tokyo (JP)

(**) **Term:** **14 Years**

(21) **Appl. No.:** **29/195,196**

(22) **Filed:** **Dec. 9, 2003**

(51) **LOC (7) Cl.** **12-16**

(52) **U.S. Cl.** **D12/178**

(58) **Field of Search** D12/110, 178;
74/551.1-551.9; 180/219; 280/274-276,
279, 288.4

(56) **References Cited**

U.S. PATENT DOCUMENTS

D431,803 S * 10/2000 Renshaw D12/178

* cited by examiner

Primary Examiner—Alan P. Douglas

Assistant Examiner—Linda Brooks

(74) *Attorney, Agent, or Firm*—Plumsea Law Group, LLC

(57) **CLAIM**

The ornamental design for a motorcycle handle bar, as shown and described.

DESCRIPTION

FIG. 1 is a front elevational view of a motorcycle handle bar showing my new design;

FIG. 2 is a side view from one side thereof;

FIG. 3 is a side view from the opposite side thereof; and,

FIG. 4 is a perspective view thereof.

The broken line showings of the handle grips, brake levers, and the mounting hardware are for illustrative purposes only and form no part of the claimed invention.

1 Claim, 3 Drawing Sheets

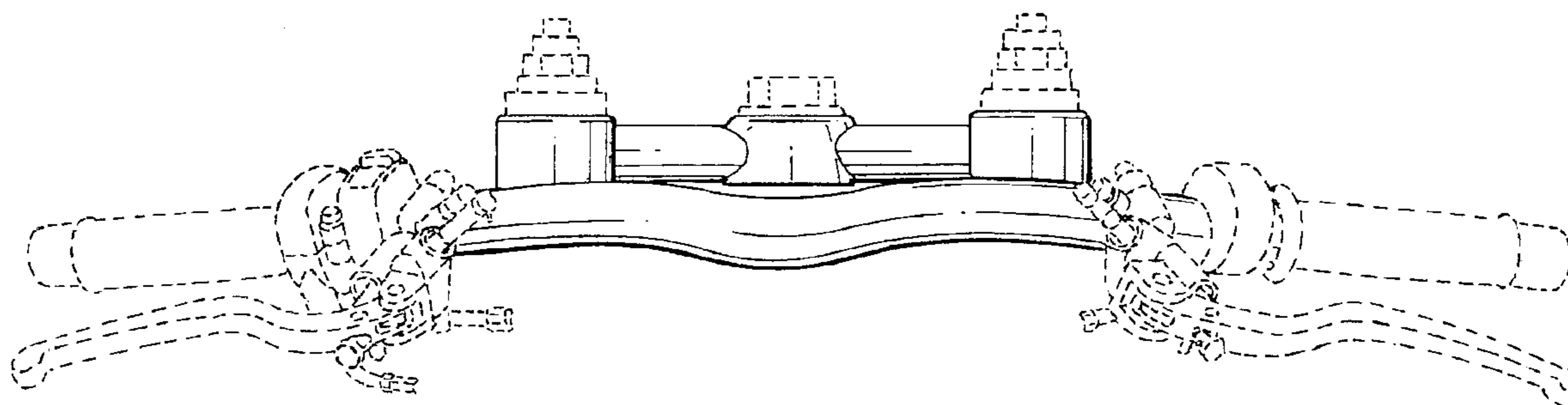

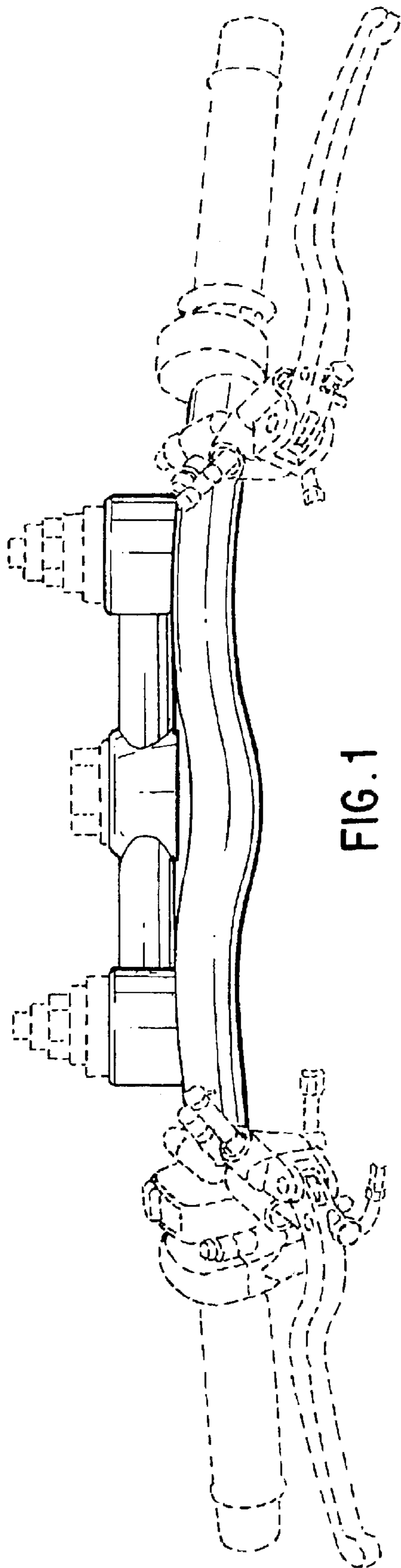

FIG. 1

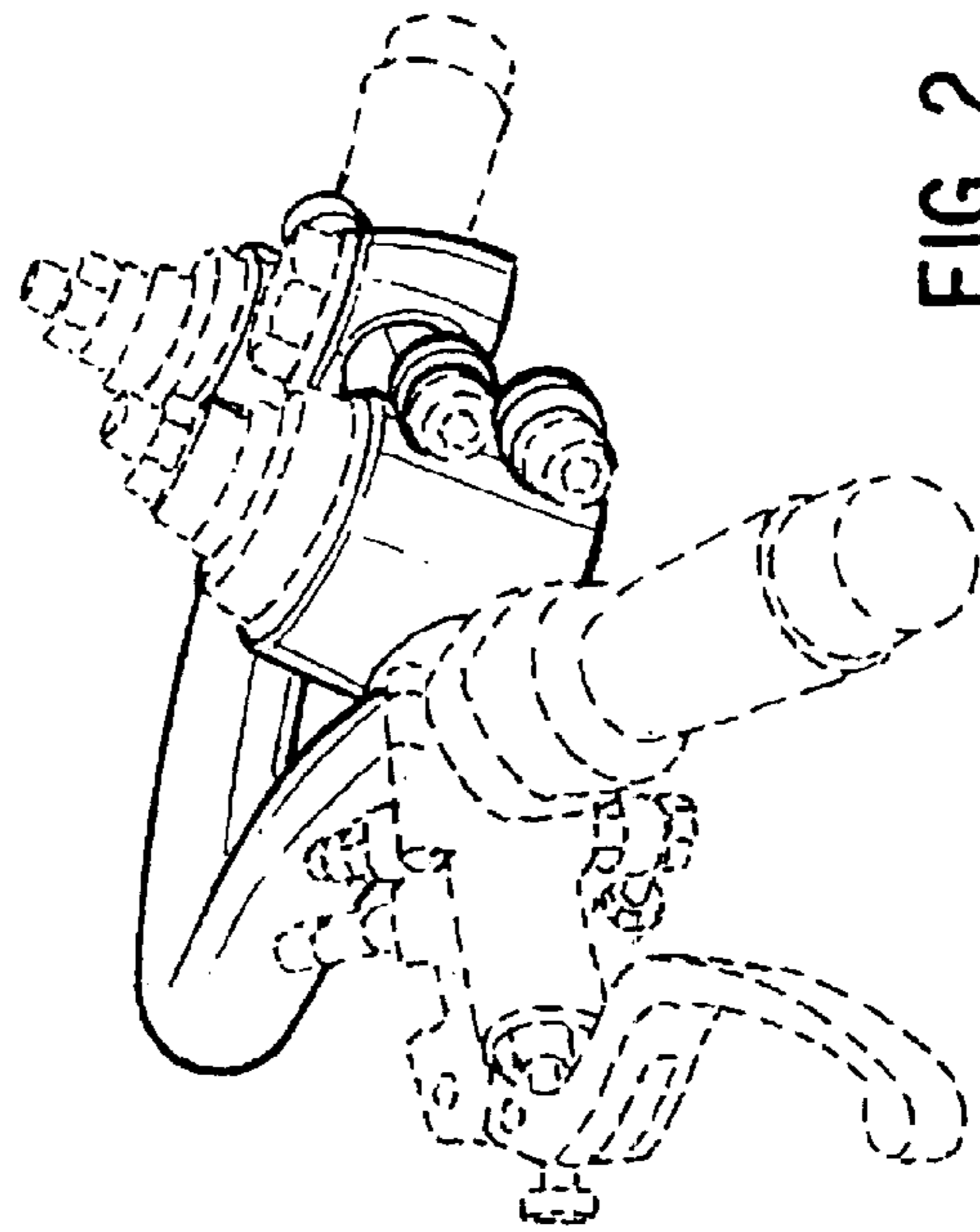

FIG. 2

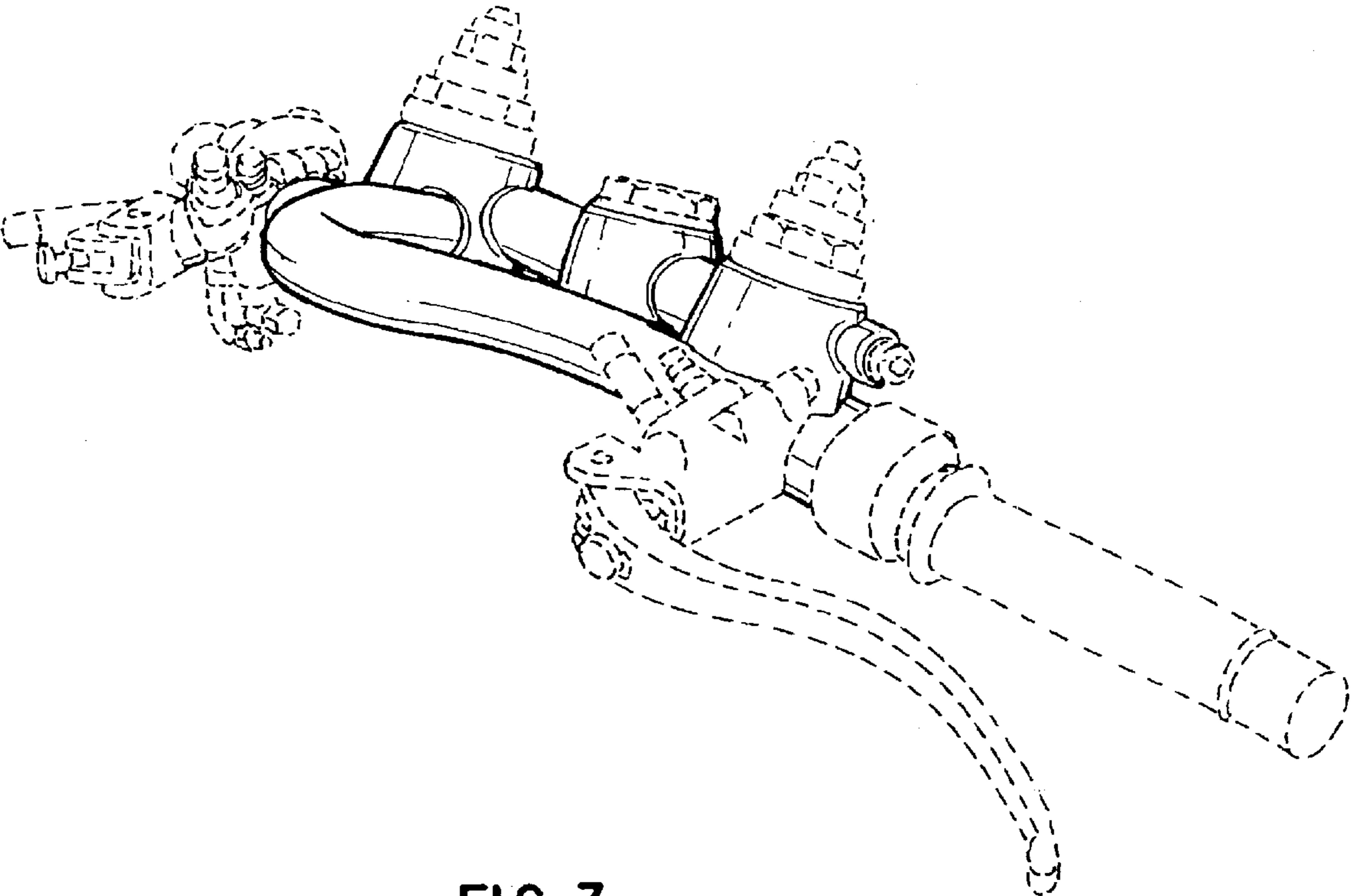

FIG. 3

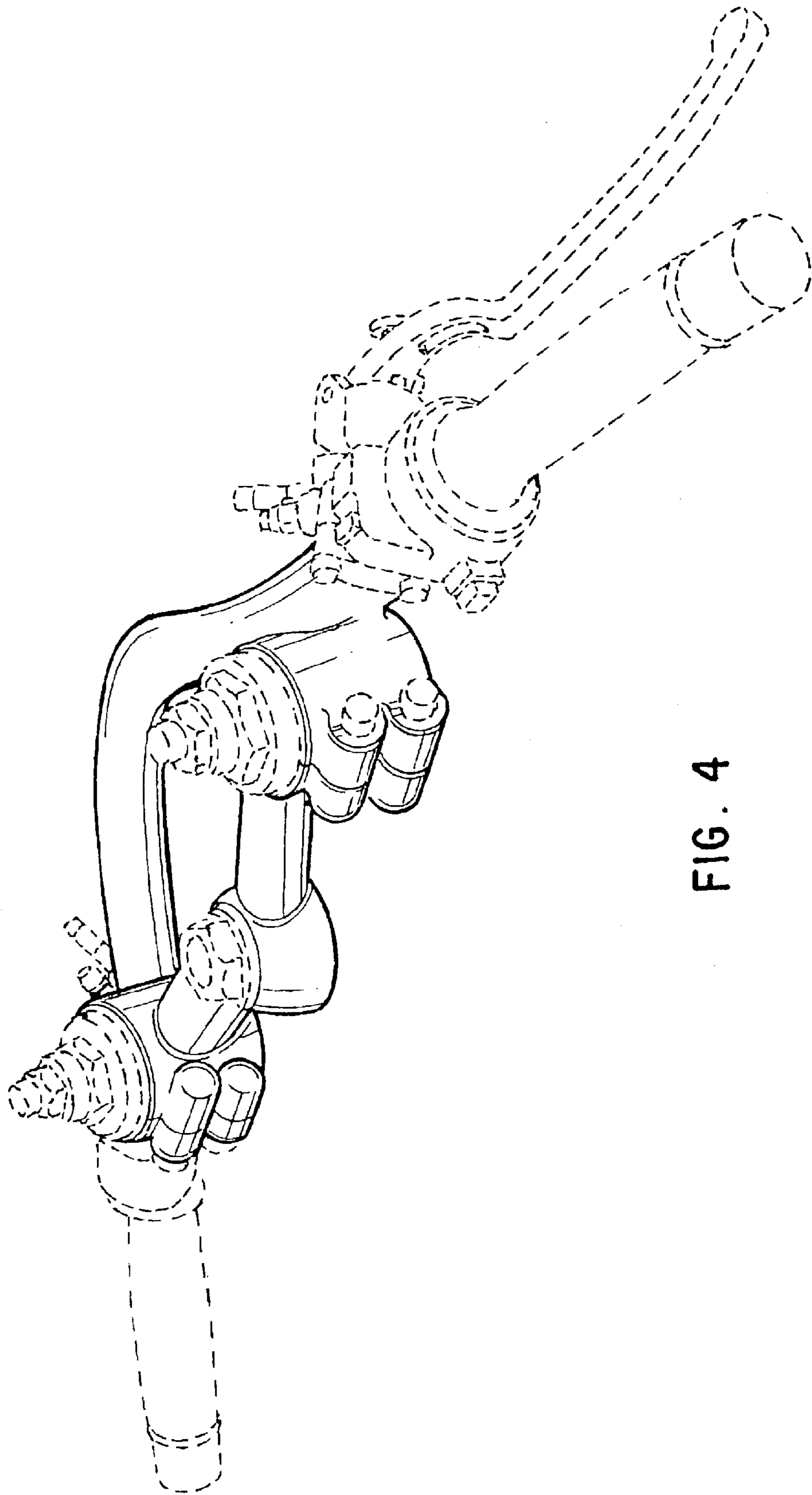

FIG. 4