

US00D497529S1

(12) **United States Design Patent** (10) **Patent No.:** **US D497,529 S**
Price (45) **Date of Patent:** **** Oct. 26, 2004**

(54) **IMPACT WRENCH**

(75) Inventor: **Scott D. Price**, Lebanon, NJ (US)

(73) Assignee: **Ingersoll-Rand Company**, Woodcliff Lake, NJ (US)

(**) Term: **14 Years**

(21) Appl. No.: **29/198,648**

(22) Filed: **Feb. 2, 2004**

(51) **LOC (7) Cl.** **08-05**

(52) **U.S. Cl.** **D8/68**

(58) **Field of Search** D8/14.1, 61, 62, D8/63, 64, 65, 66, 67, 68, 69, 70; 81/57.11, 429, 464, 465, 466, 469, 489; 173/13, 169, 178, 213, 217; 227/8, 114, 120, 130, 136, 142; 310/50; 408/20, 124, 125, 234, 241 R; 451/358

(56) **References Cited**

U.S. PATENT DOCUMENTS

D205,091 S	*	6/1966	Averitt	D8/68
3,352,368 A	*	11/1967	Maffey, Jr.	173/169
3,354,732 A	*	11/1967	Wickham	173/169
D256,980 S	*	9/1980	Adams et al.	D8/68
D339,726 S	*	9/1993	Bruno et al.	D8/68
D388,678 S	*	1/1998	Bantly et al.	D8/68
D393,580 S	*	4/1998	Bantly et al.	D8/68
D403,564 S	*	1/1999	Izumisawa	D8/68
D434,297 S	*	11/2000	Iritani et al.	D8/68
D434,298 S	*	11/2000	Izumisawa	D8/68
D434,958 S	*	12/2000	Izumisawa	D8/68
D436,818 S	*	1/2001	Izumisawa	D8/68

D441,628 S	*	5/2001	Bass et al.	D8/68
6,338,389 B1	*	1/2002	Chang	173/169
D458,824 S	*	6/2002	Chen	D8/68
D465,982 S	*	11/2002	Taga	D8/68
D469,673 S	*	2/2003	Sliker et al.	D8/68
D472,782 S	*	4/2003	Pusateri et al.	D8/68
D476,210 S	*	6/2003	Chen	D8/68
D477,512 S	*	7/2003	Liu et al.	D8/68
D477,761 S	*	7/2003	Liu et al.	D8/68
D477,977 S	*	8/2003	Liu	D8/68
D482,947 S	*	12/2003	Lin	D8/68
2002/0152848 A1	*	10/2002	Johnson	81/465

* cited by examiner

Primary Examiner—James Gandy

Assistant Examiner—T. Chase Nelson

(74) *Attorney, Agent, or Firm*—Michael Best & Friedrich LLP

(57) **CLAIM**

I claim the ornamental design for an impact wrench, as shown and described.

DESCRIPTION

FIG. 1 is a left side view of an impact wrench showing our design;

FIG. 2 is a right side view of FIG. 1;

FIG. 3 is a front view of FIG. 1;

FIG. 4 is a rear view of FIG. 1;

FIG. 5 is a top view of FIG. 1; and,

FIG. 6 is a bottom view of FIG. 1.

The structural features depicted by means of broken lines in the drawing figures have been shown for illustrative purposes only and form no part of the claimed design.

1 Claim, 4 Drawing Sheets

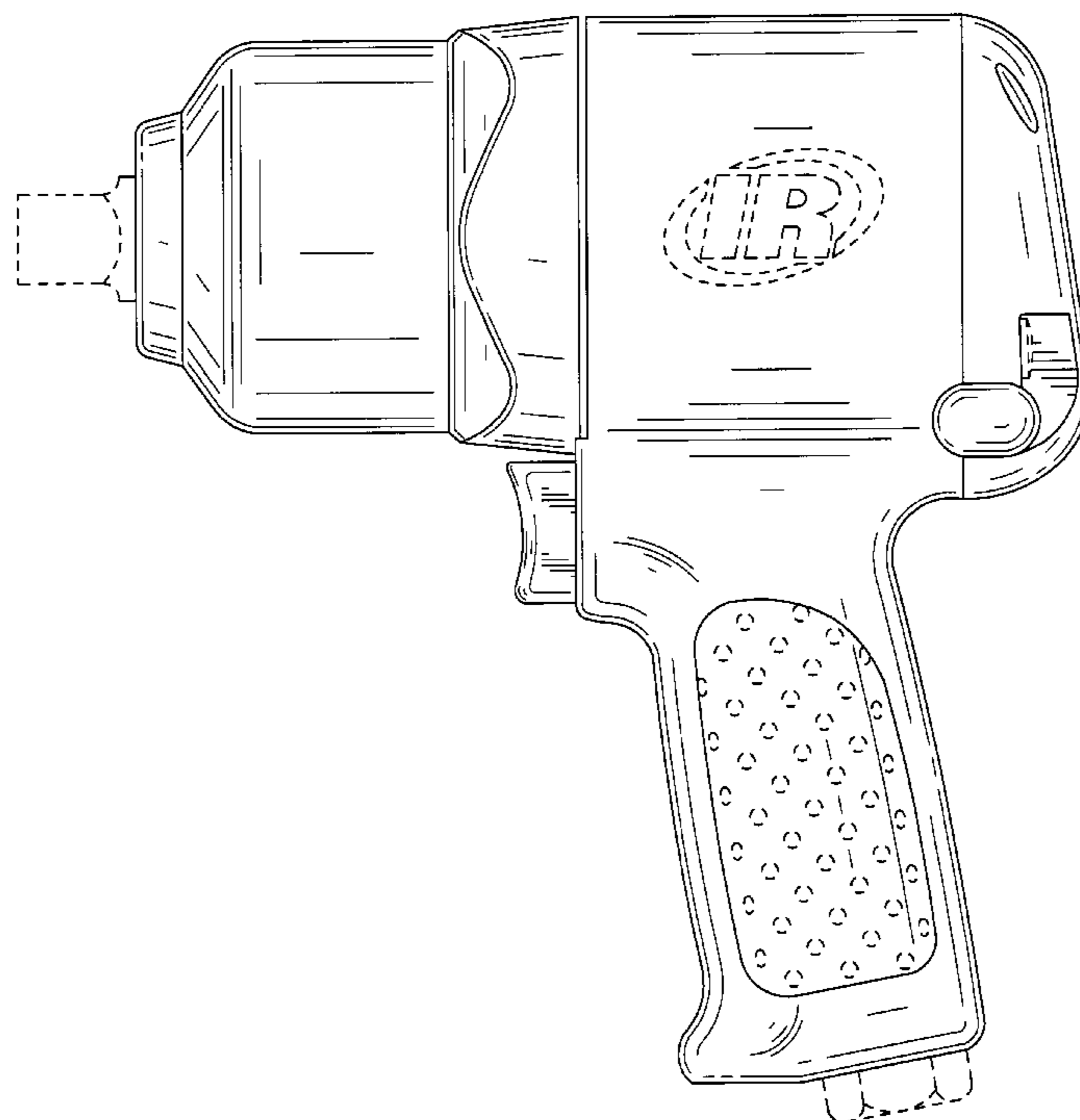

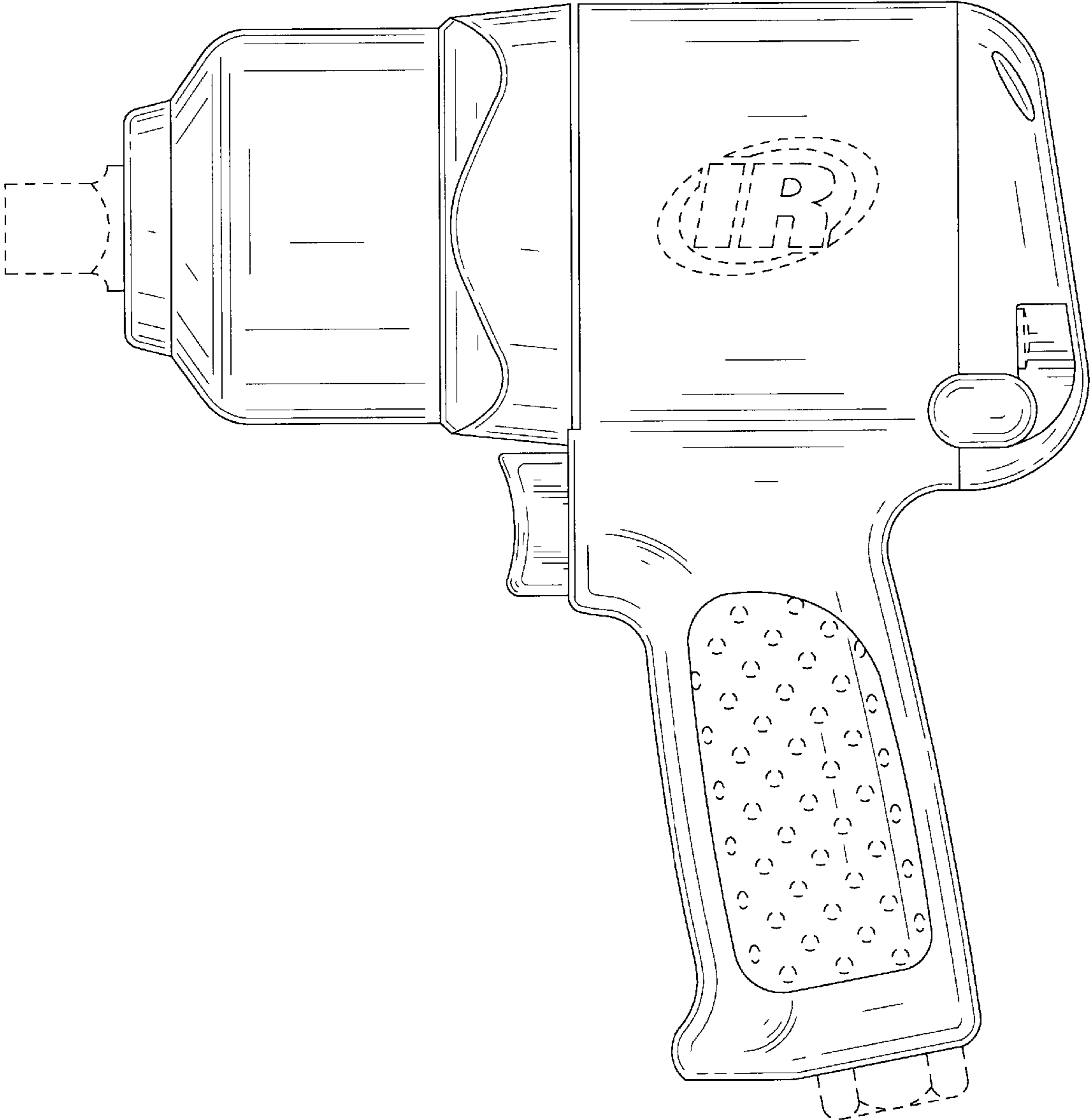

FIG. 1

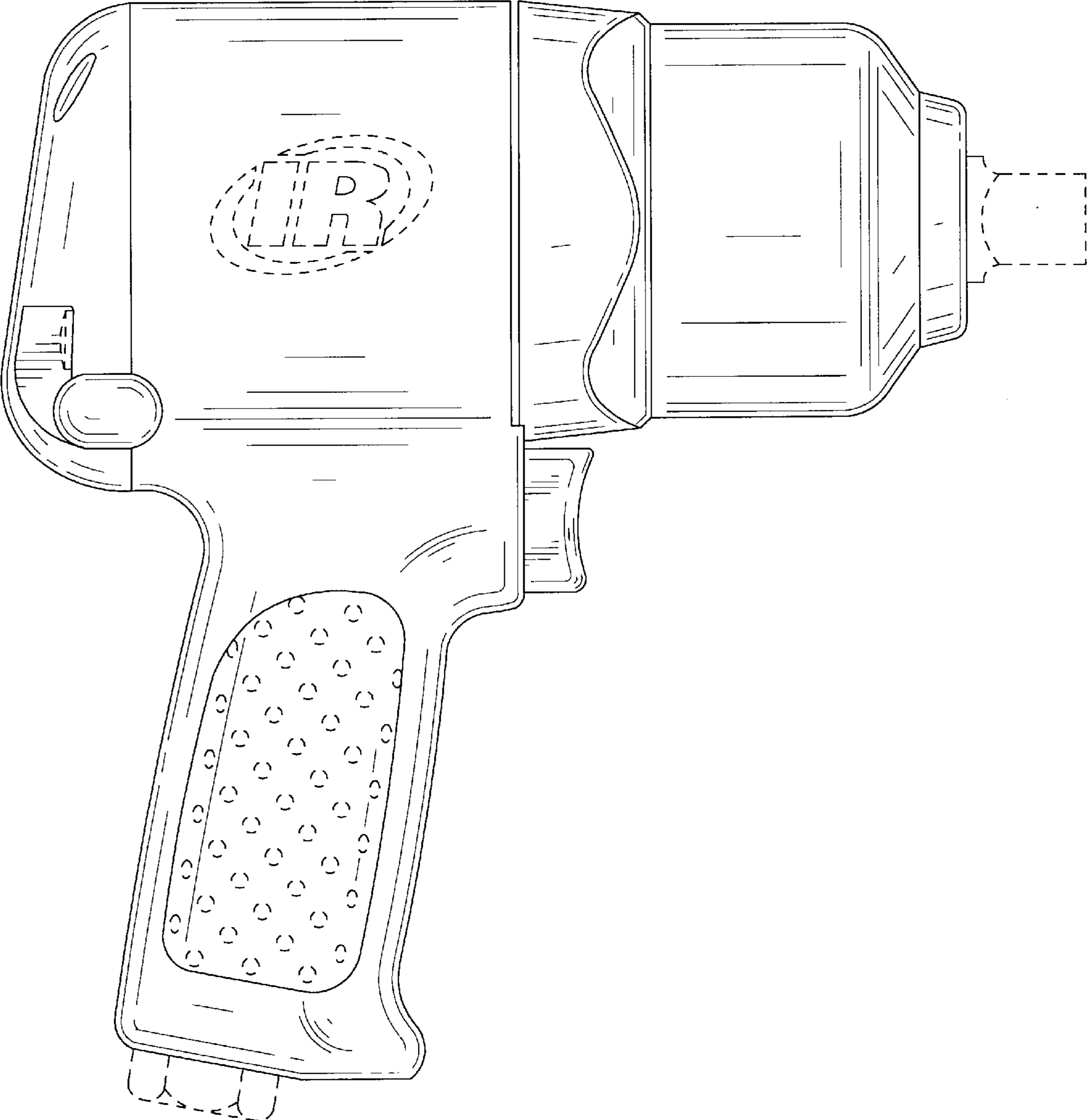

FIG. 2

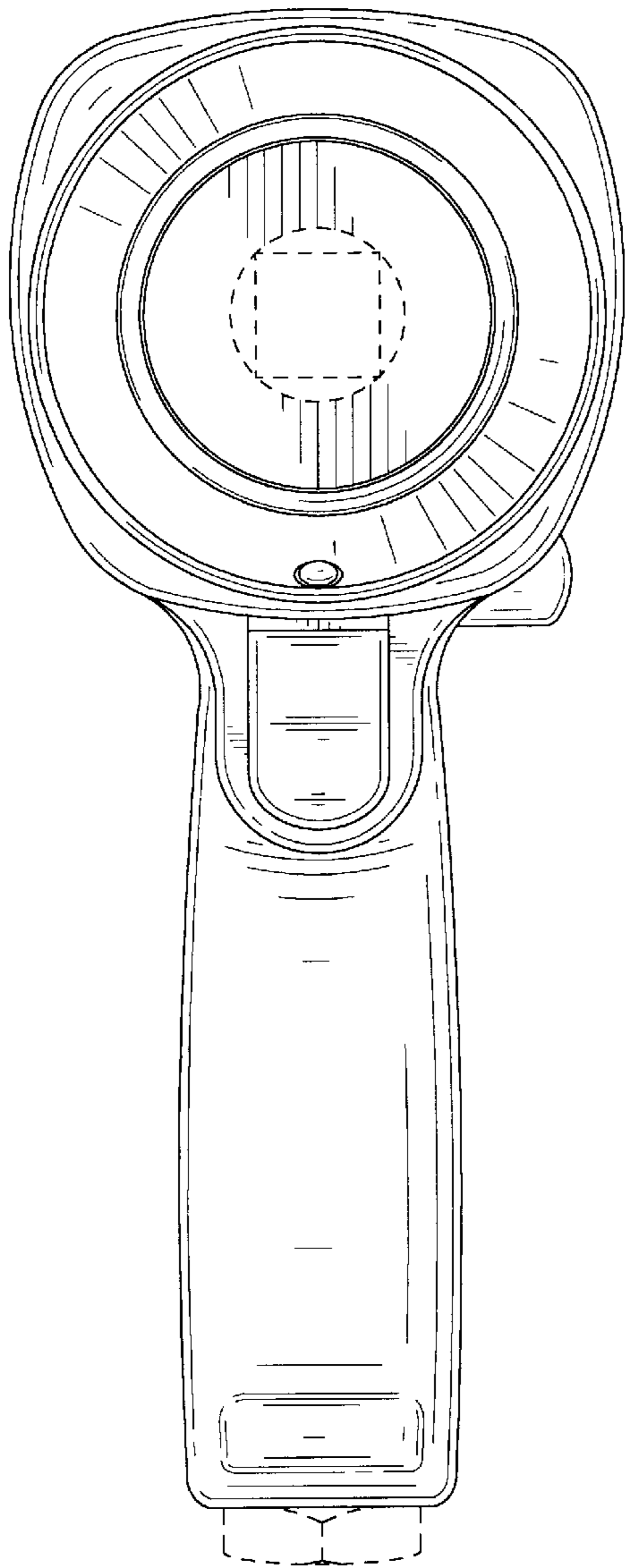

FIG. 3

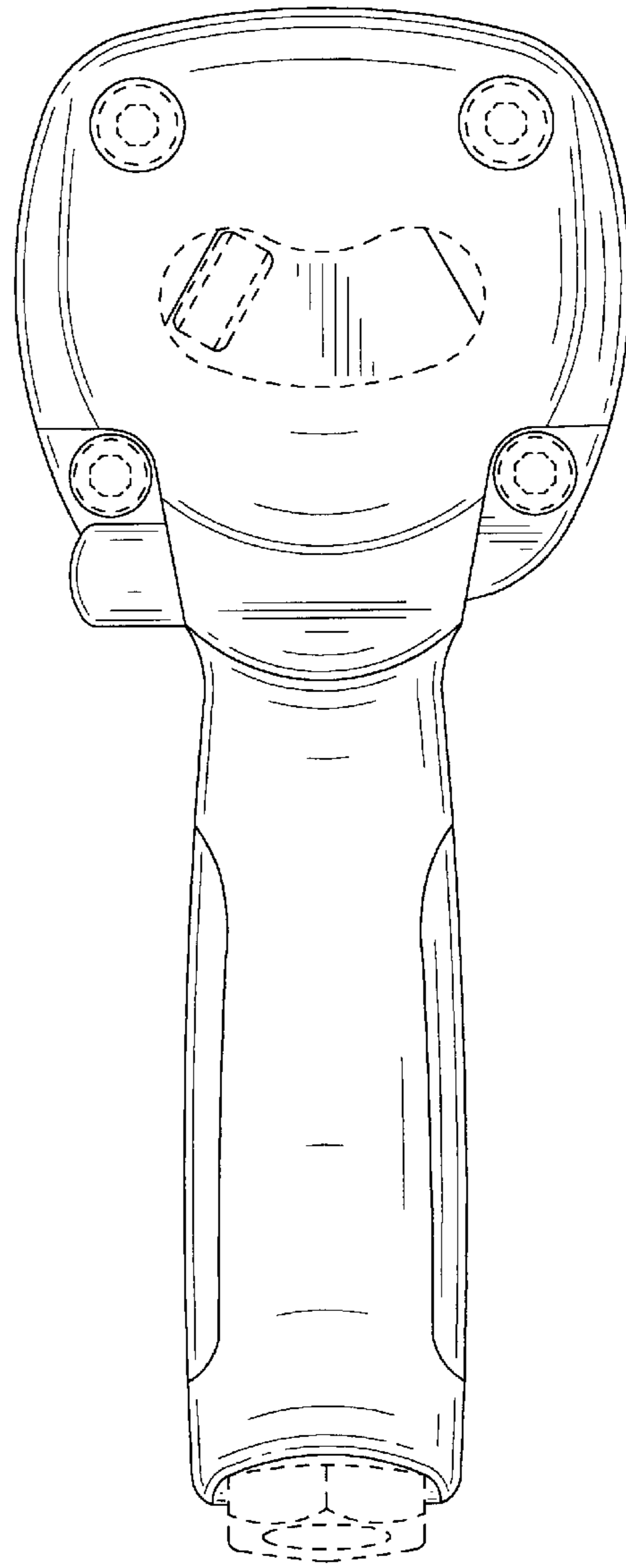

FIG. 4

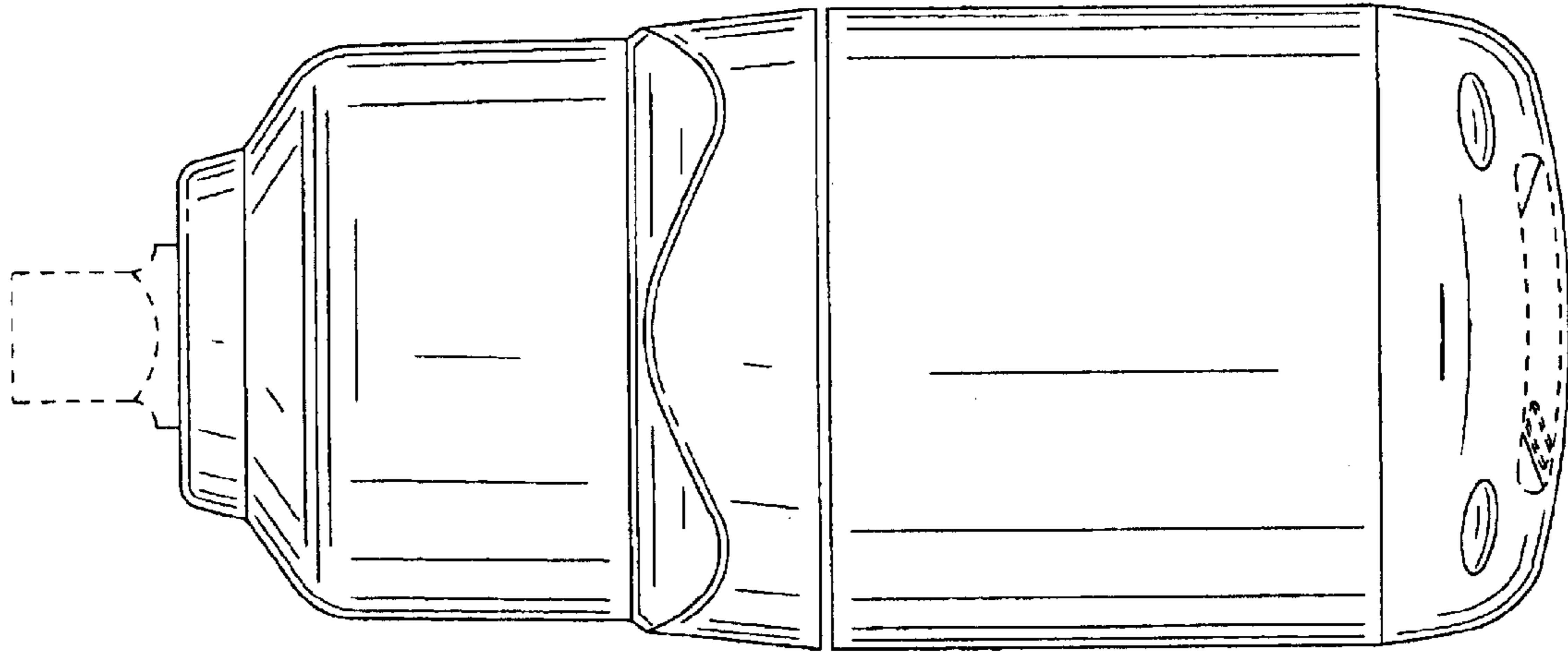

FIG. 5

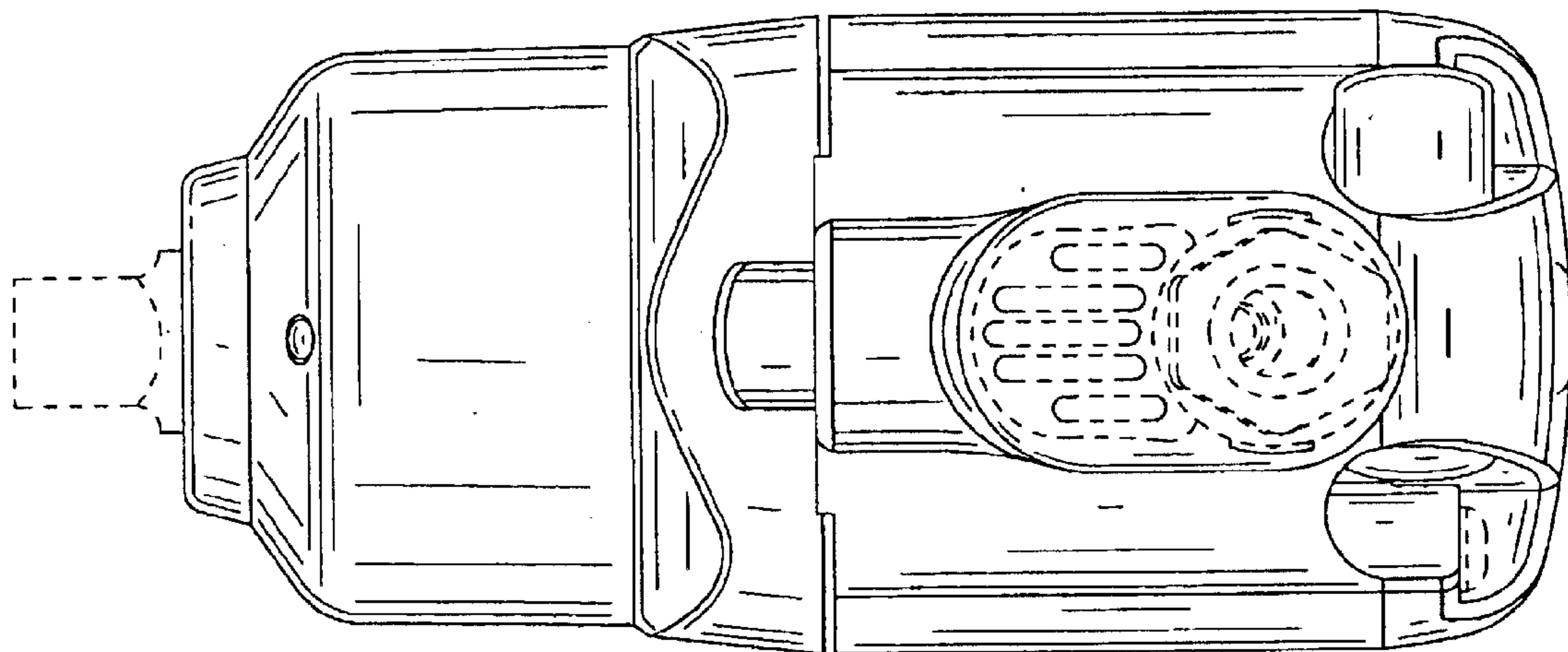

FIG. 6