

US00D497480S1

(12) **United States Design Patent** (10) **Patent No.:** **US D497,480 S**
Drew et al. (45) **Date of Patent:** **** Oct. 26, 2004**

(54) **UPRIGHT HANDLE ASSEMBLY FOR LUGGAGE**

(75) Inventors: **Jason Drew**, Port Jefferson, NY (US); **Georgene Rada**, East Northport, NY (US); **Richard J. Krulik**, Dix Hills, NY (US)

(73) Assignee: **Briggs & Riley Travelware LLC**, Hauppauge, NY (US)

(**) Term: **14 Years**

(21) Appl. No.: **29/178,176**

(22) Filed: **Mar. 21, 2003**

(51) **LOC (7) Cl.** **03-99**

(52) **U.S. Cl.** **D3/318**

(58) **Field of Search** D3/318, 320-323, D3/319, 302, 316; D34/24, 26; 190/18 A, 39, 115, 102, 113

(56) **References Cited**

U.S. PATENT DOCUMENTS

6,186,295 B1 *	2/2001	Lin et al.	190/18 A
D457,320 S *	5/2002	Beedham	D3/318
D472,713 S *	4/2003	Lee	D3/318
D477,916 S *	8/2003	Nykoluk	D3/318

* cited by examiner

Primary Examiner—Catherine R. Oliver

(74) *Attorney, Agent, or Firm*—Abelman, Frayne & Schwab

(57) **CLAIM**

The upright handle assembly for luggage, as shown and described.

DESCRIPTION

FIG. 1 is a front, bottom and left side perspective view of the upright handle assembly for luggage constructed according to our new design, the portions in dash lines being shown for environmental purposes only and forming no part of our claimed design;

FIG. 2 is a top, rear and left side perspective view of the upright handle assembly for luggage of FIG. 1;

FIG. 3 is a rear elevational view thereof;

FIG. 4 is a top plan view thereof;

FIG. 5 is a bottom plan view thereof;

FIG. 6 is a front elevational view thereof;

FIG. 7 is a right side elevational view thereof, the left side elevational view being a mirror image thereof;

FIG. 8 is a view of the upright handle assembly for luggage similar to FIG. 1, on a reduced scale, shown in an upside down condition;

FIG. 9 is a view of the upright handle assembly for luggage similar to FIG. 1, with the handle portion in an extended position; and,

FIG. 10 is a rear elevational view of another alternative embodiment of our new design for an upright handle assembly for luggage similar to FIG. 3, showing the axle support portions in dash lines for environmental purposes and forming no part of this particular claimed design.

1 Claim, 8 Drawing Sheets

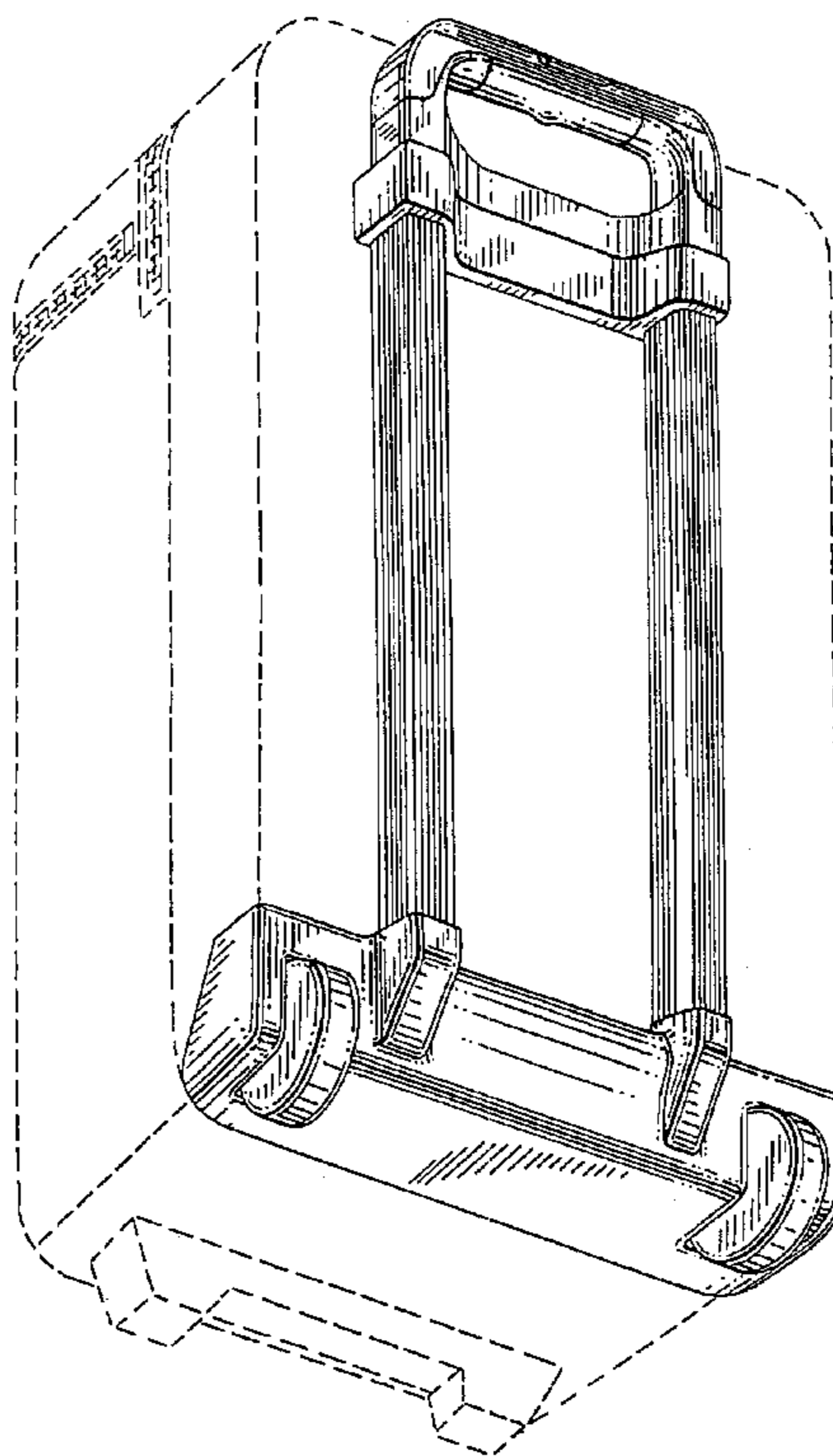

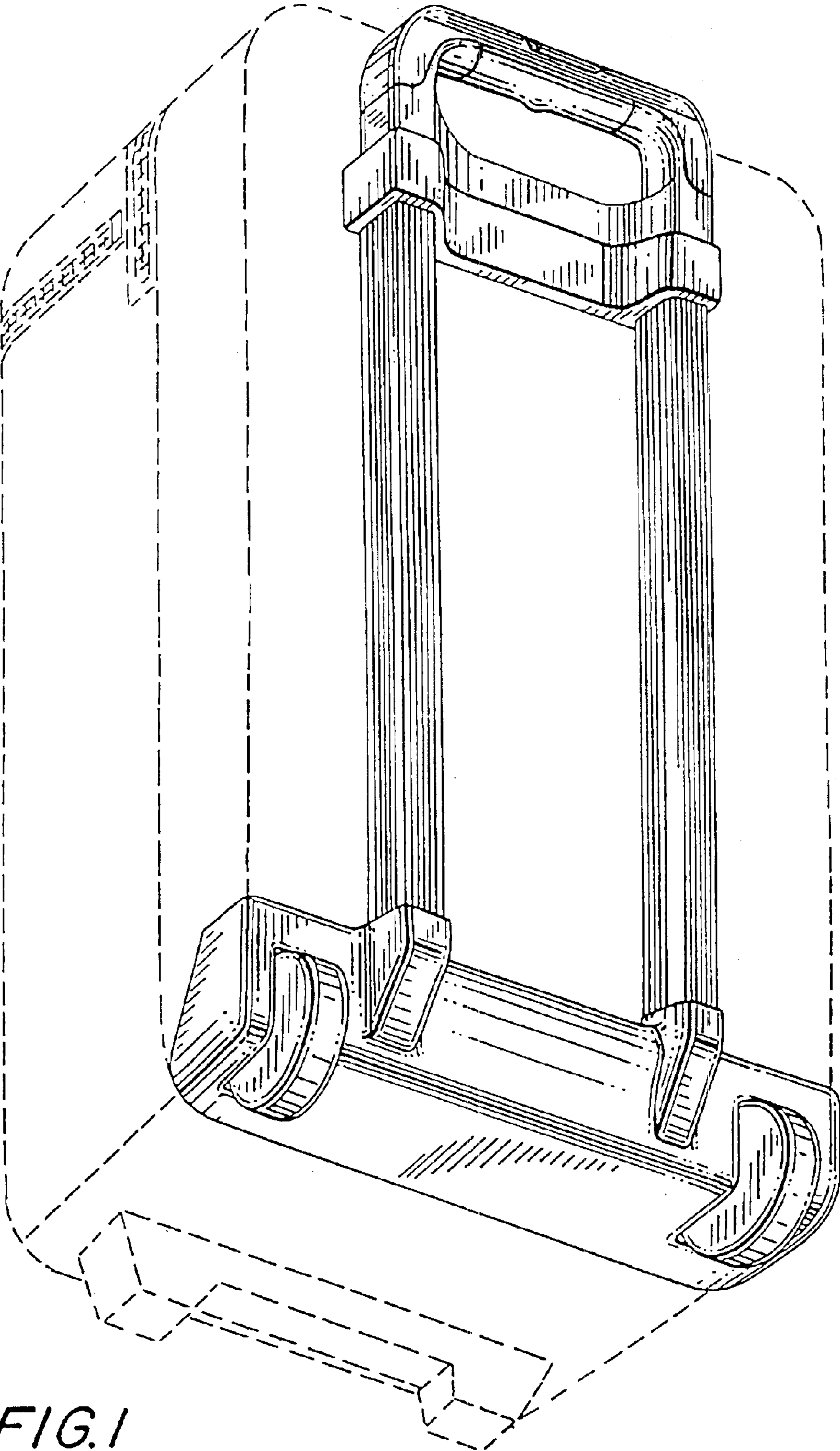

FIG. 1

FIG. 2

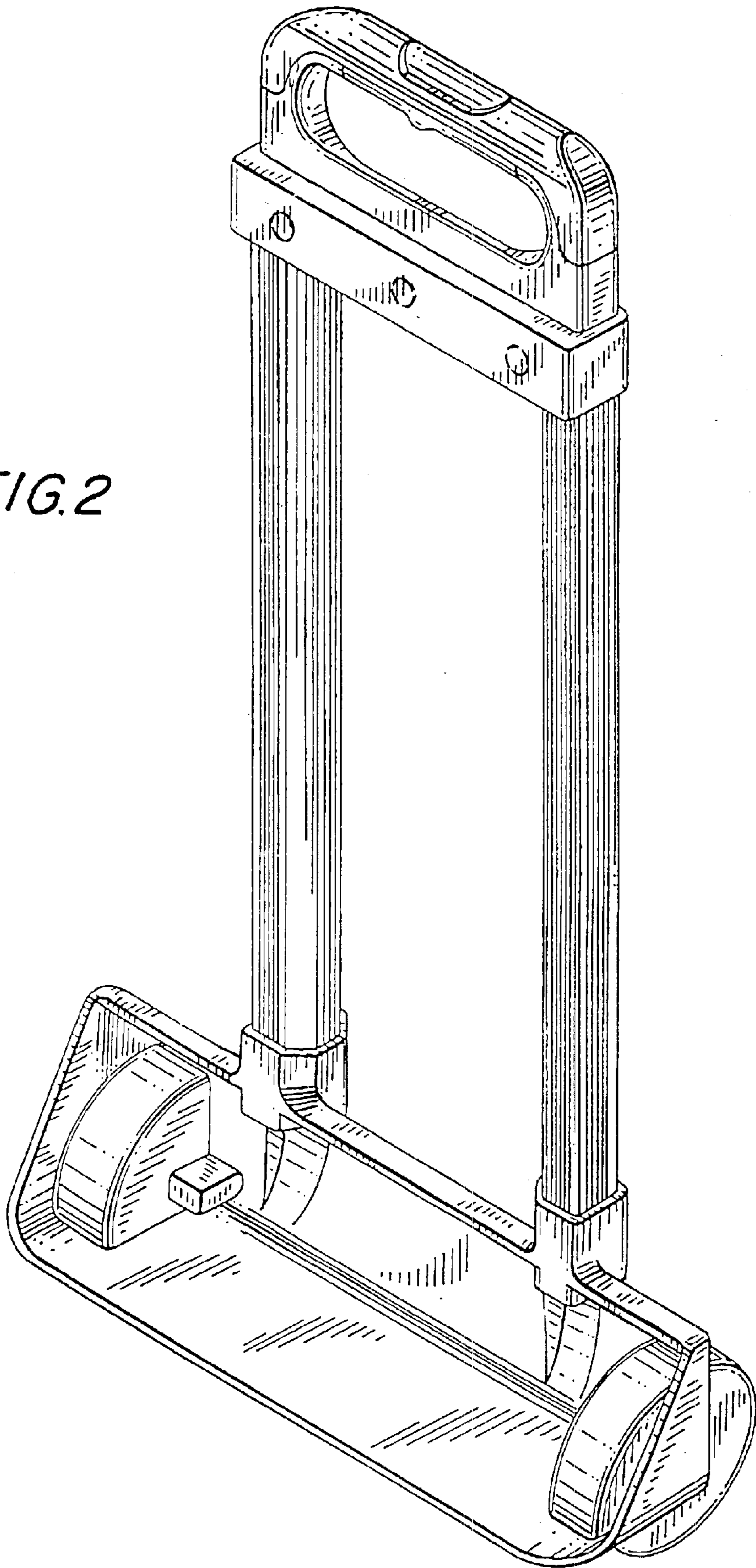

FIG. 3

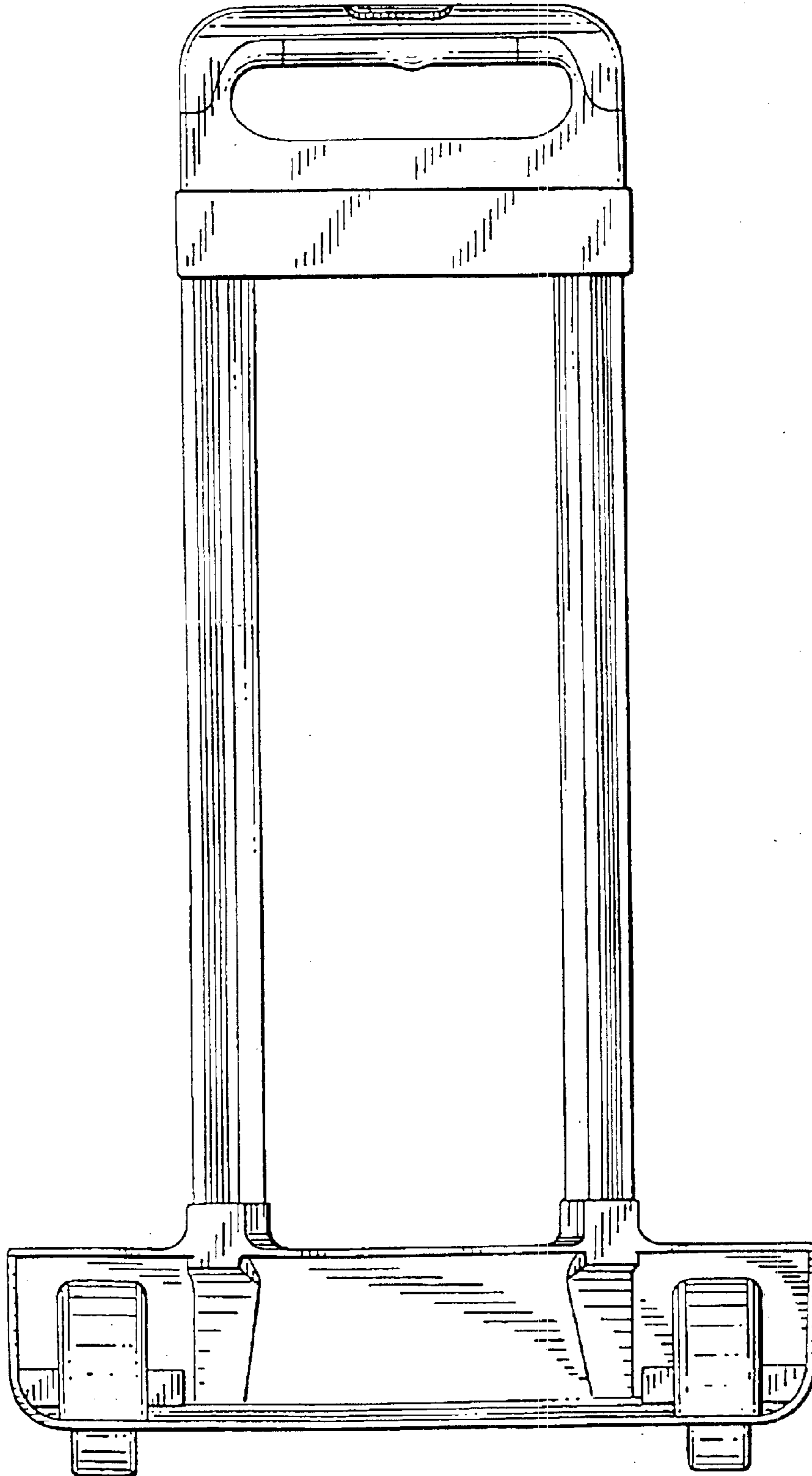

FIG. 4

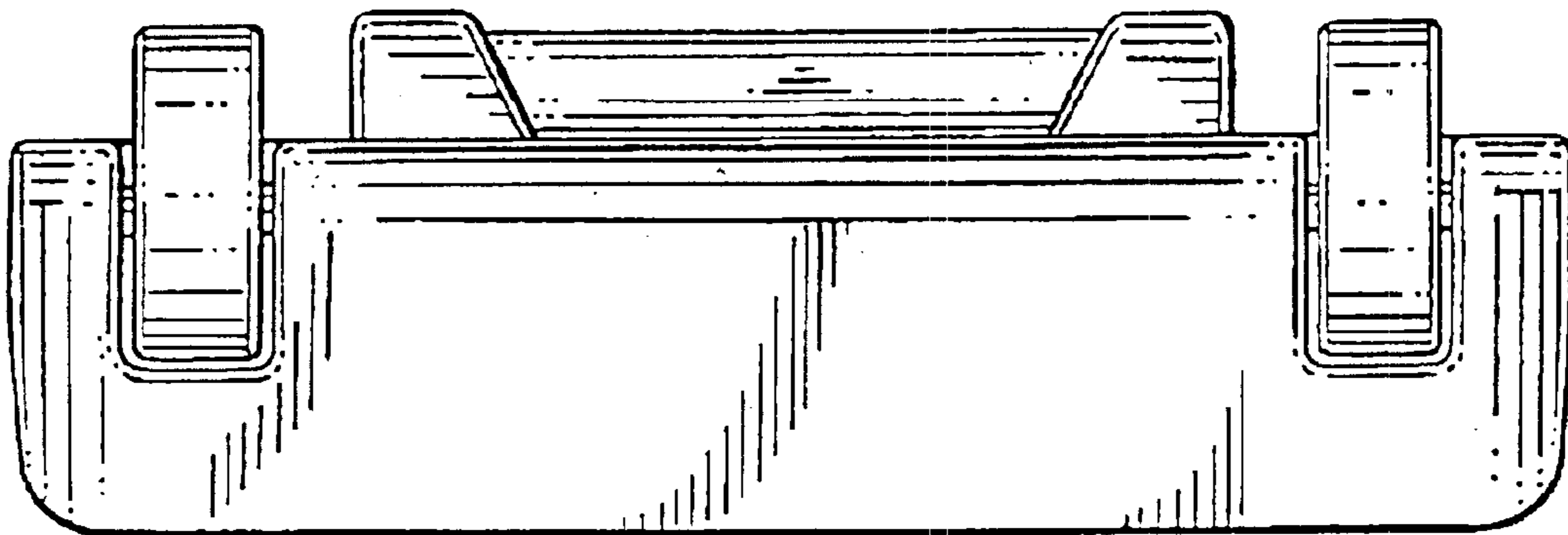
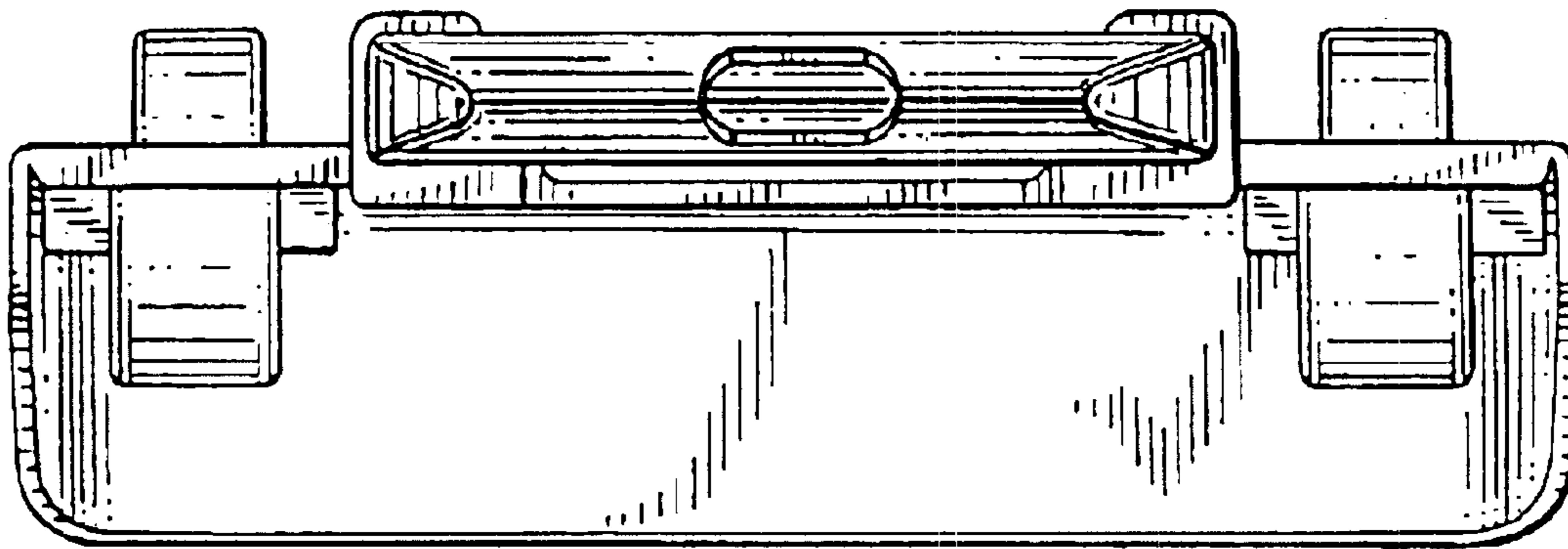

FIG. 5

FIG. 6

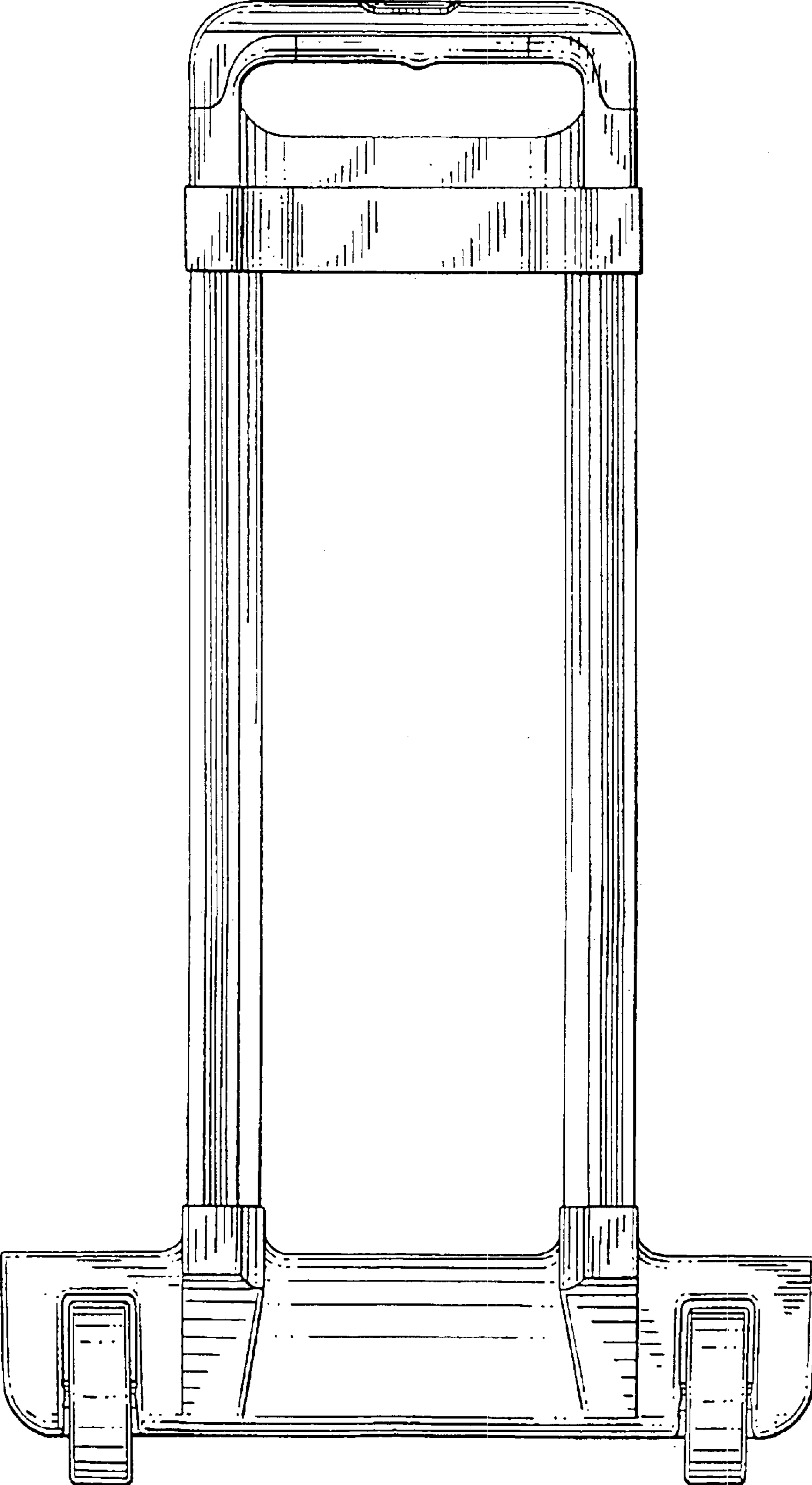

FIG. 7

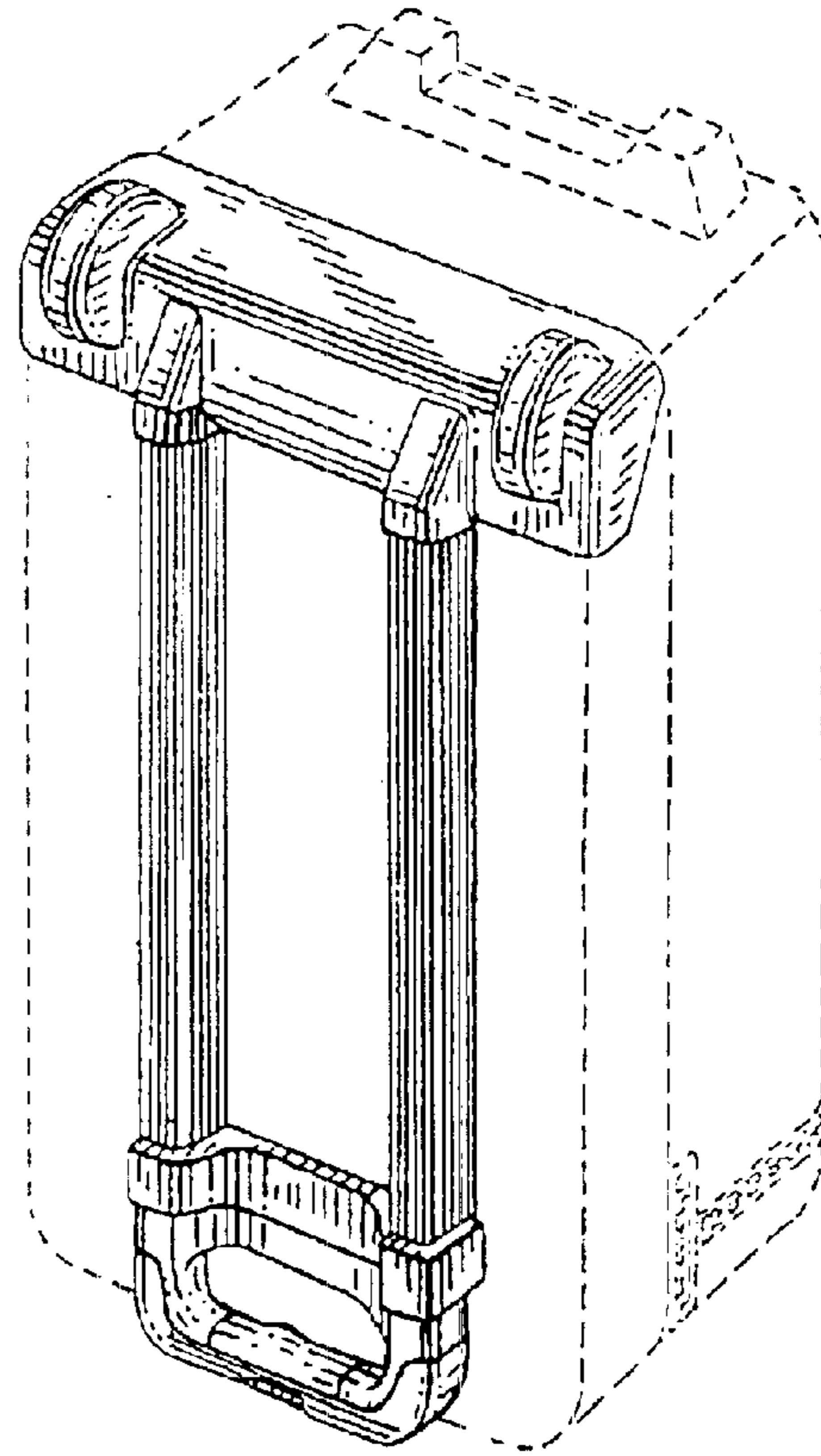
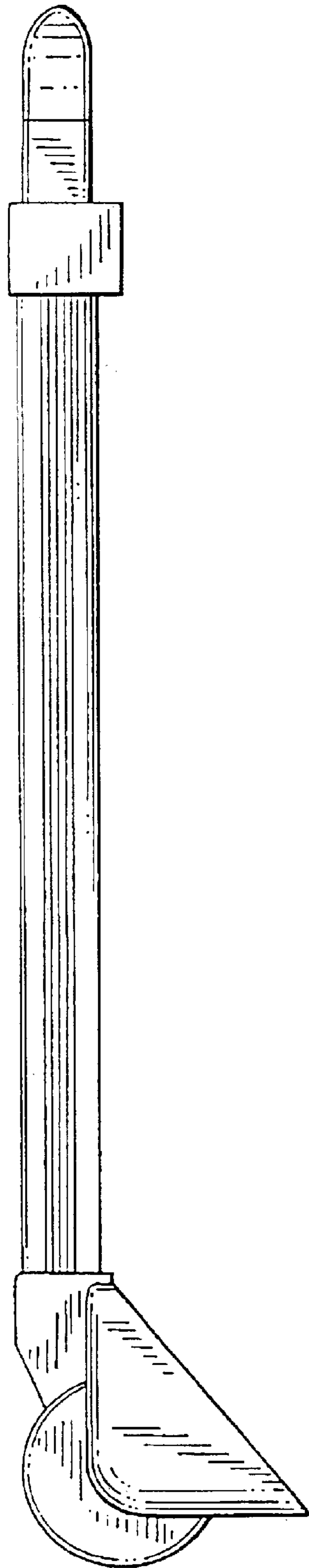

FIG. 8

FIG. 9

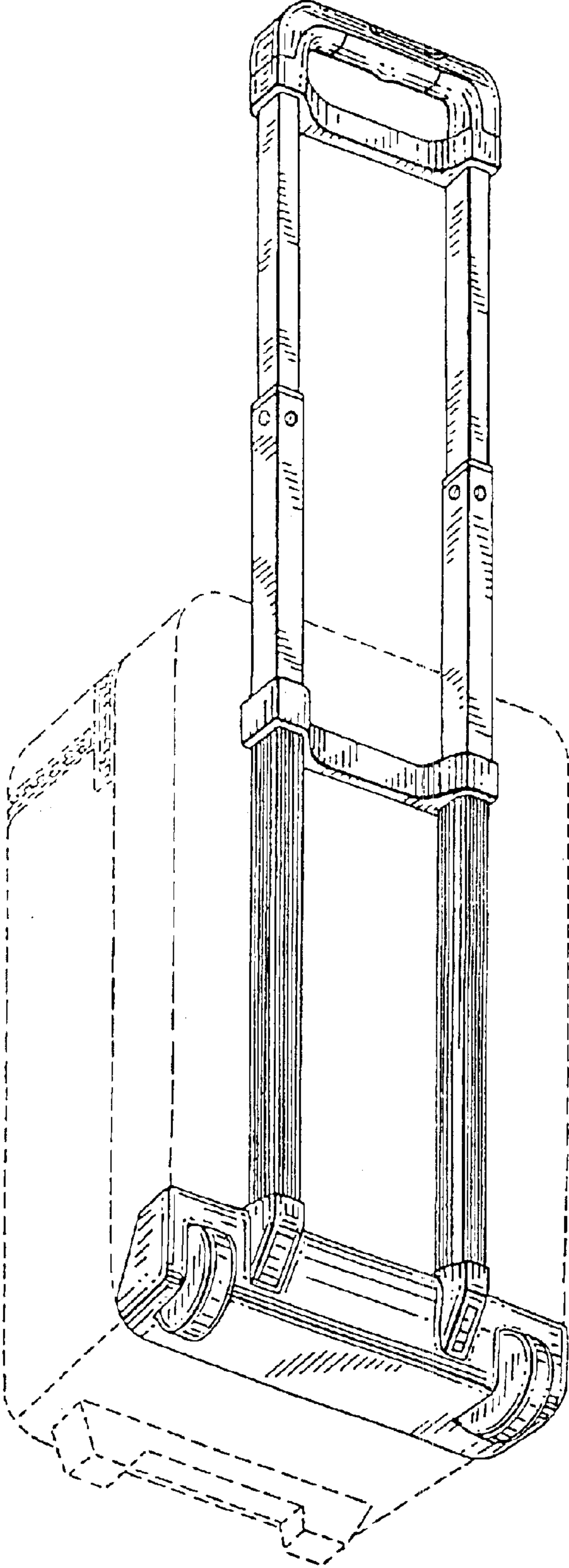

FIG. 10

