

US00D497371S1

(12) **United States Design Patent** (10) **Patent No.:** **US D497,371 S**
Waggle et al. (45) **Date of Patent:** **** Oct. 19, 2004**

(54) **CUTTING TOOL INSERT**

(75) Inventors: **James M. Waggle**, Derry, PA (US);
Jeffrey F. Kovac, Latrobe, PA (US);
Nicholas M. Gaten, Greensburg, PA (US)

(73) Assignee: **Kennametal Inc.**, Latrobe, PA (US)

(**) Term: **14 Years**

(21) Appl. No.: **29/192,990**

(22) Filed: **Oct. 31, 2003**

(51) **LOC (7) Cl.** **15-09**

(52) **U.S. Cl.** **D15/139**

(58) **Field of Search** D15/139; 407/113-118

(56) **References Cited**

U.S. PATENT DOCUMENTS

D364,178 S	*	11/1995	Hansson et al.	D15/139
6,186,705 B1	*	2/2001	Kumar et al.	407/114
6,267,541 B1	*	7/2001	Isakov et al.	407/114
2004/0037659 A1	*	2/2004	Sung et al.	407/114

OTHER PUBLICATIONS

Mitsubishi Tool News CVD coated grade for milling cast iron F5020.

* cited by examiner

Primary Examiner—Antoine D. Davis

(74) *Attorney, Agent, or Firm*—Larry R. Meenan

(57) **CLAIM**

The ornamental design for a cutting tool insert, as shown and described.

DESCRIPTION

FIG. 1 is a front, perspective view of a cutting insert showing our new design;

FIG. 2 is a rear, perspective view of the cutting insert of FIG. 1;

FIG. 3 is a side view of the cutting insert of FIG. 1;

FIG. 4 is a side view of the cutting insert of FIG. 1;

FIG. 5 is a side view of the cutting insert of FIG. 1;

FIG. 6 is a side view of the cutting insert of FIG. 1;

FIG. 7 is a front view of the cutting insert of FIG. 1; and

FIG. 8 is a back view of the cutting insert of FIG. 1.

FIG. 9 is a front, perspective view of an alternate cutting insert showing a modified embodiment of our new design;

FIG. 10 is a rear, perspective view of the cutting insert of FIG. 9;

FIG. 11 is a side view of the cutting insert of FIG. 9;

FIG. 12 is a side view of the cutting insert of FIG. 9;

FIG. 13 is a side view of the cutting insert of FIG. 9;

FIG. 14 is a side view of the cutting insert of FIG. 9;

FIG. 15 is a front view of the cutting insert of FIG. 9; and

FIG. 16 is a back view of the cutting insert of FIG. 9.

FIG. 17 is a front, perspective view of an alternate cutting insert showing a modified embodiment of our new design;

FIG. 18 is a rear, perspective view of the cutting insert of FIG. 17;

FIG. 19 is a side view of the cutting insert of FIG. 17;

FIG. 20 is a side view of the cutting insert of FIG. 17;

FIG. 21 is a side view of the cutting insert of FIG. 17;

FIG. 22 is a side view of the cutting insert of FIG. 17;

FIG. 23 is a front view of the cutting insert of FIG. 17; and,

FIG. 24 is a back view of the cutting insert of FIG. 17.

1 Claim, 6 Drawing Sheets

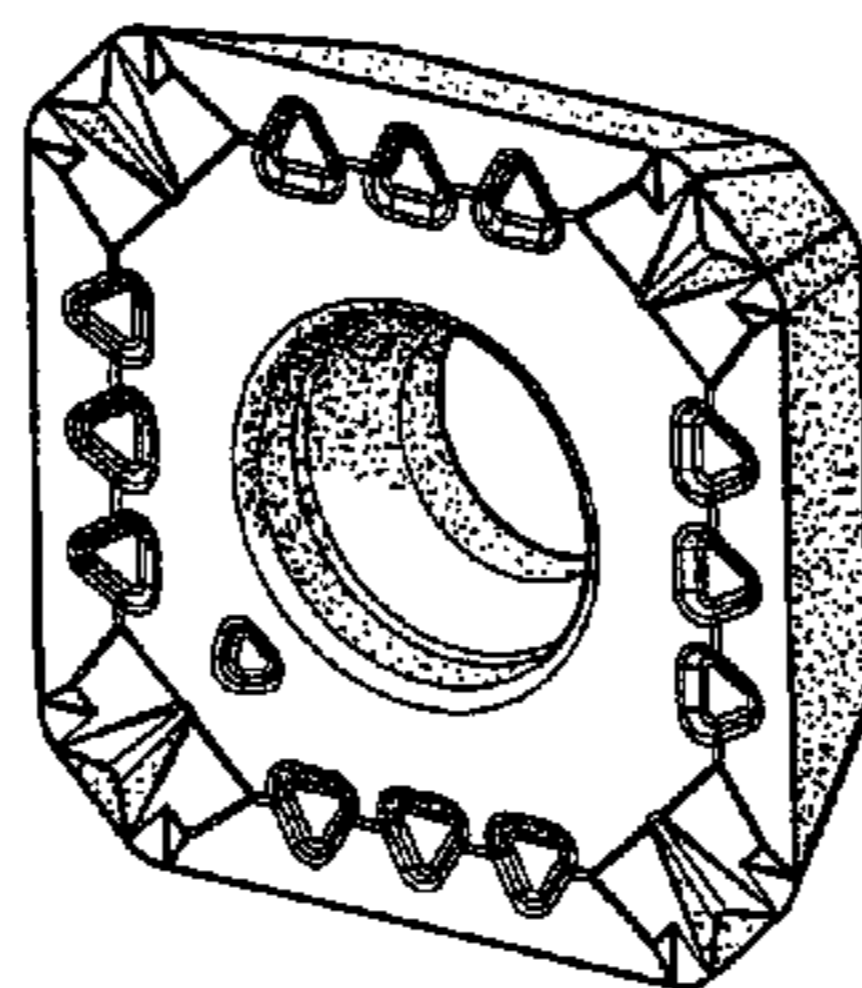

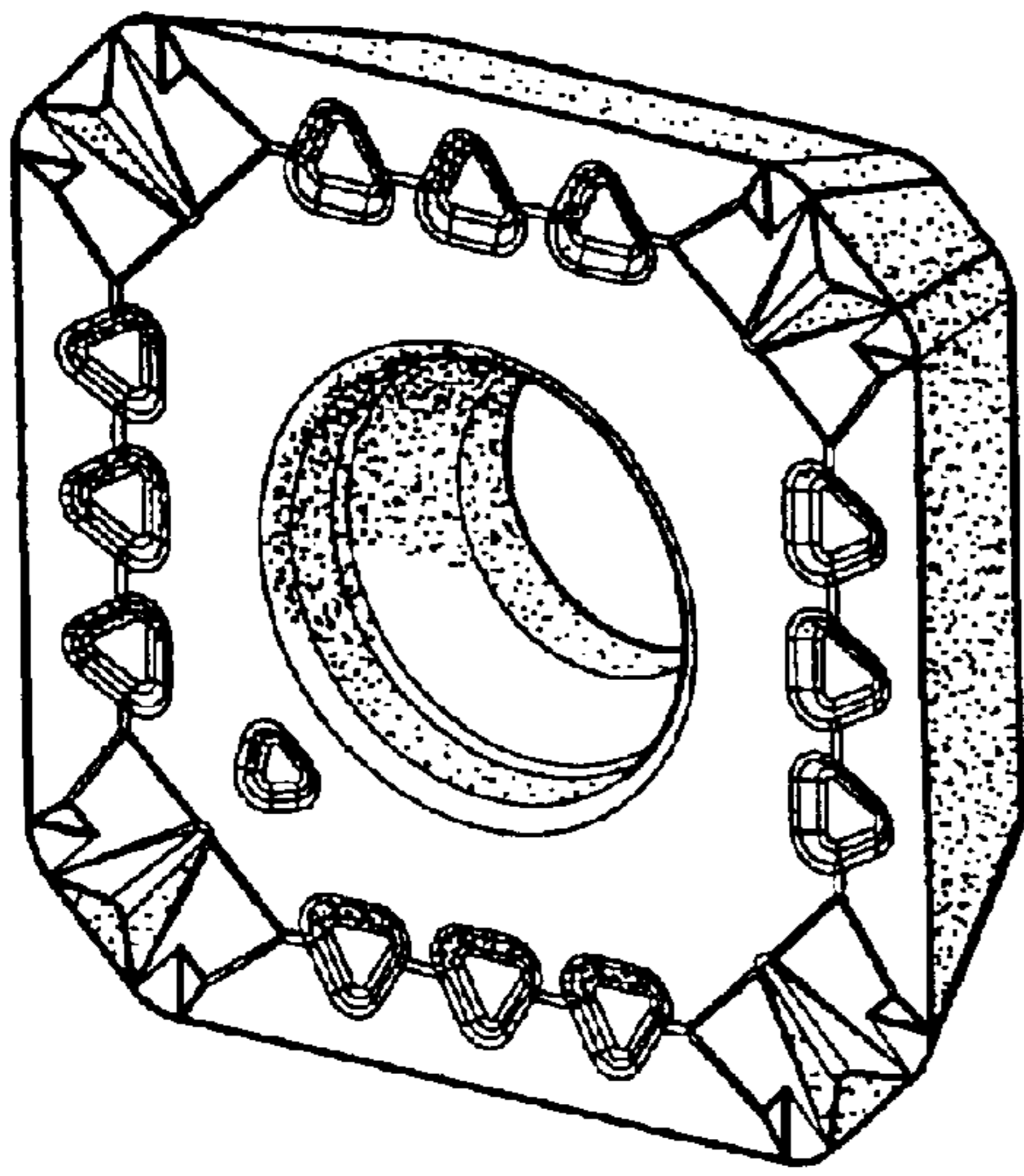

FIG. 1

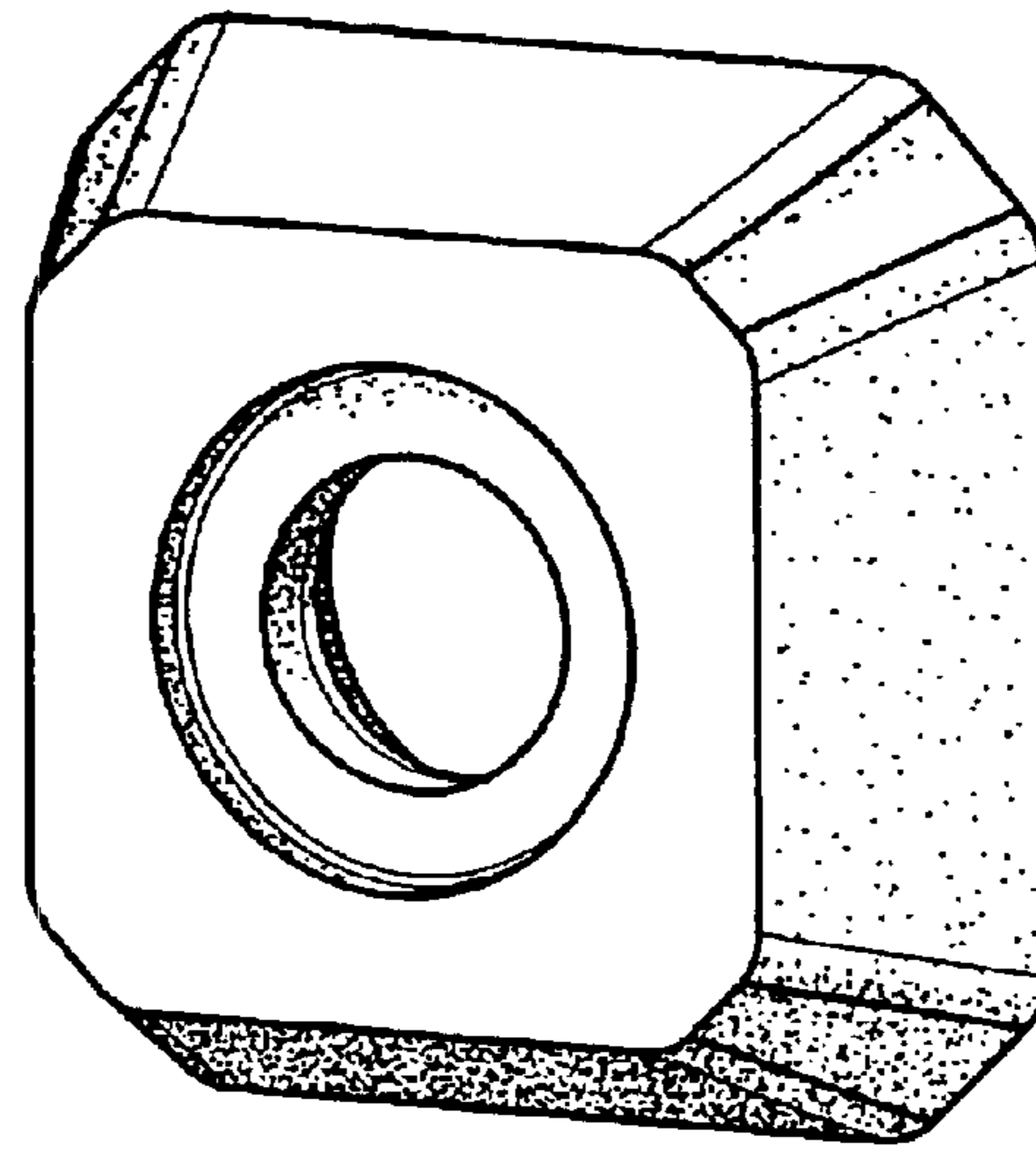

FIG. 2

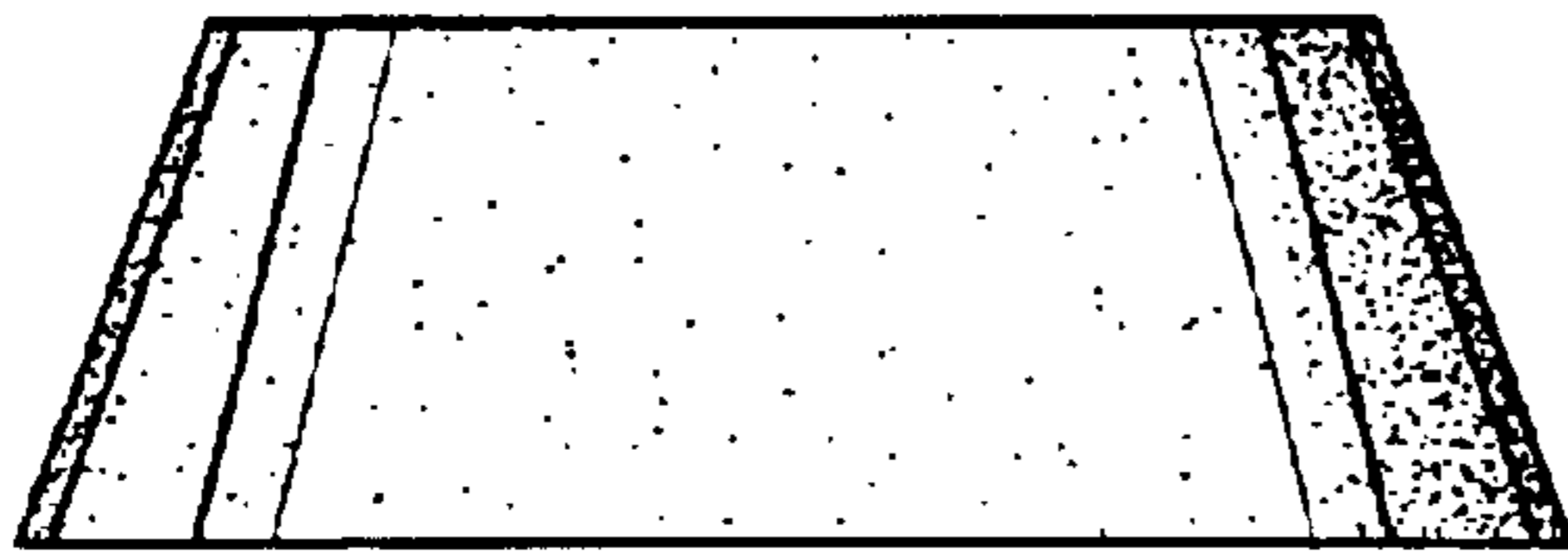

FIG. 3

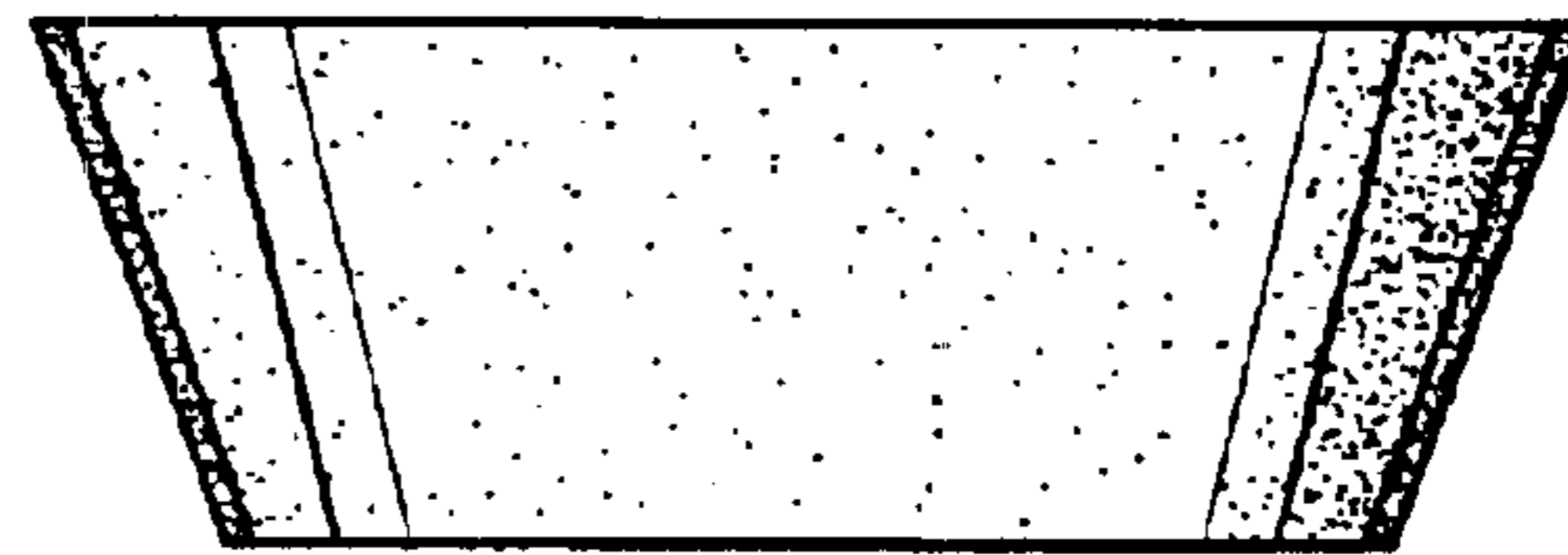

FIG. 4

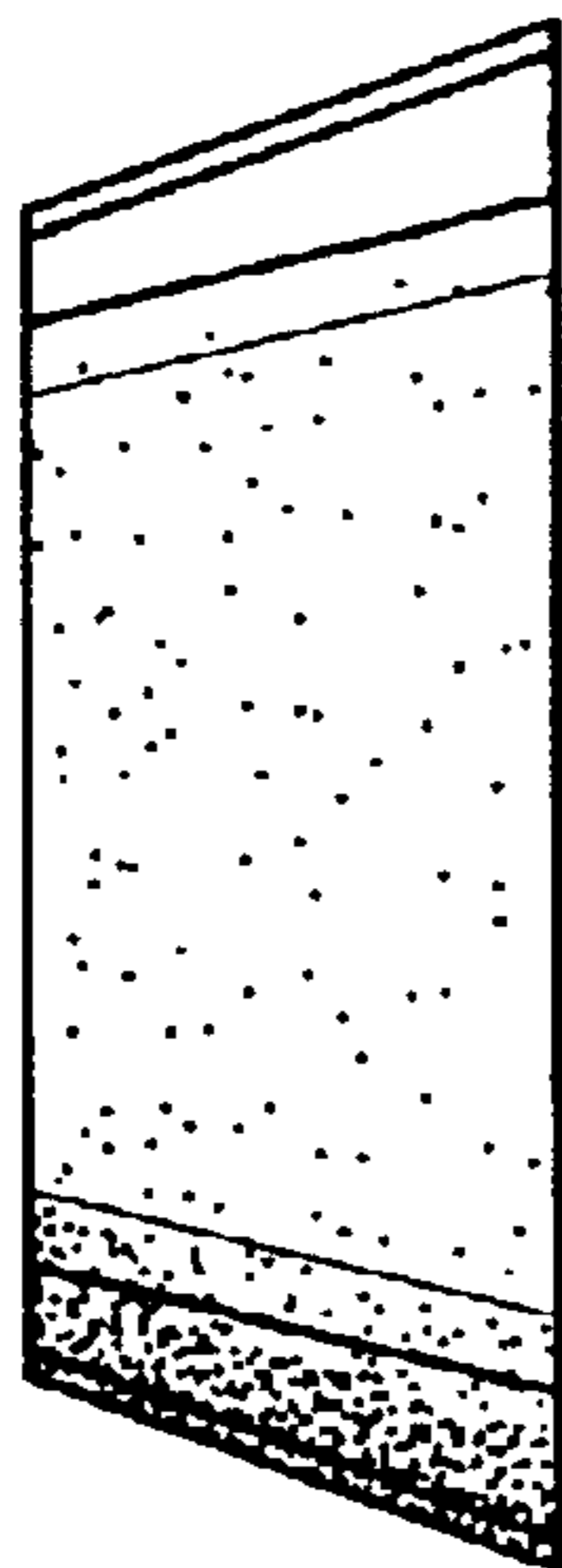

FIG. 5

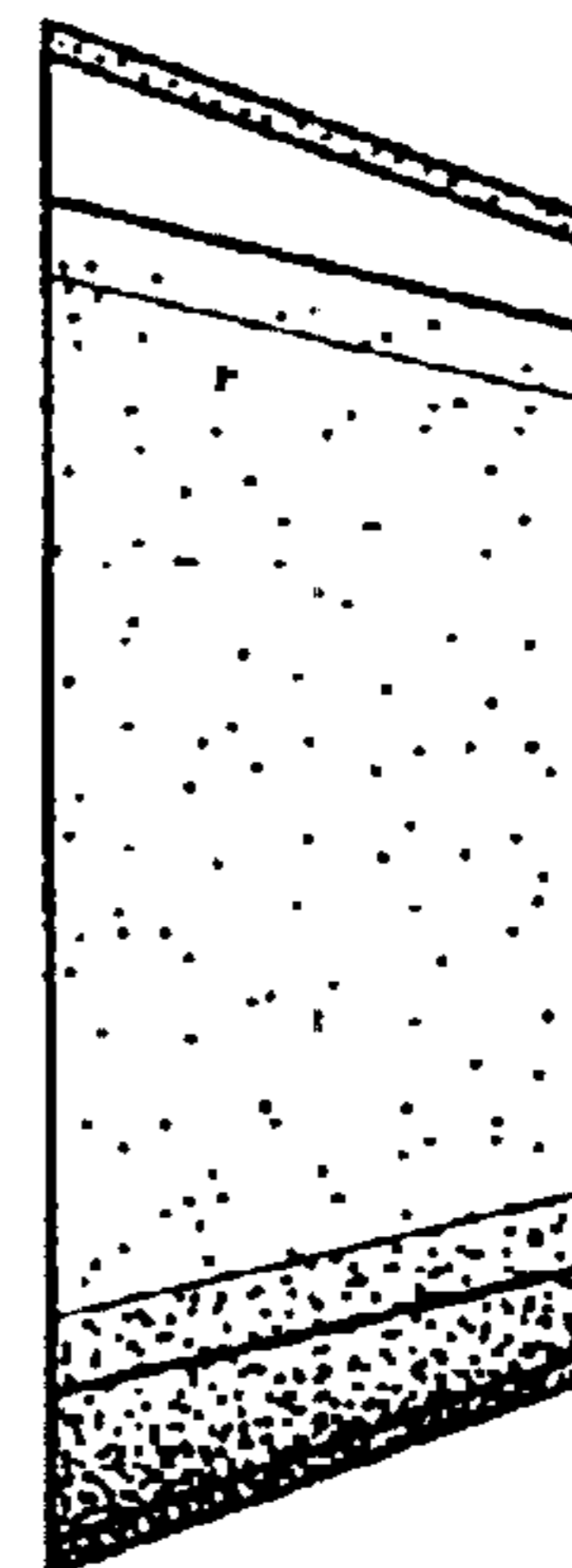

FIG. 6

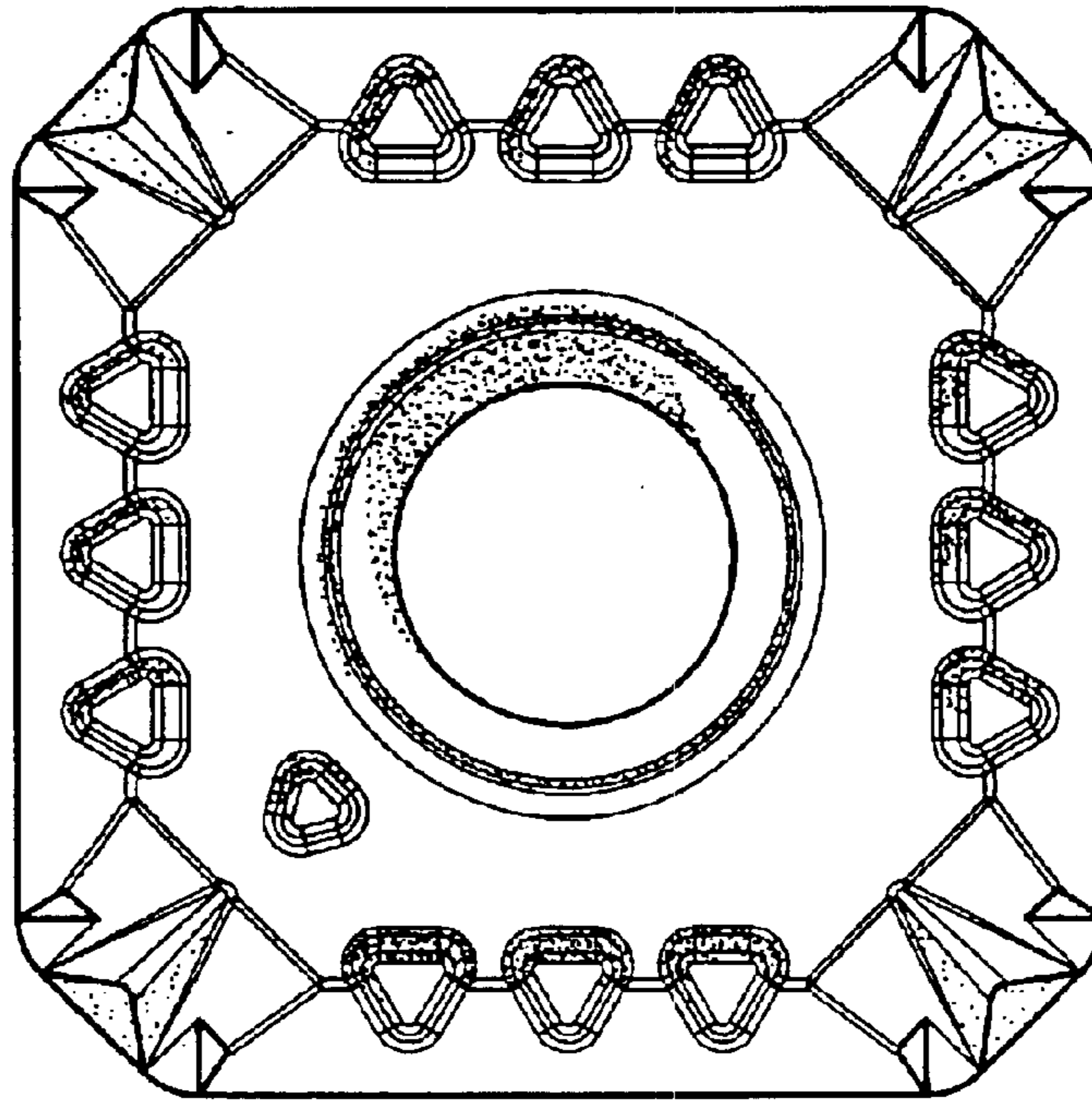

FIG. 7

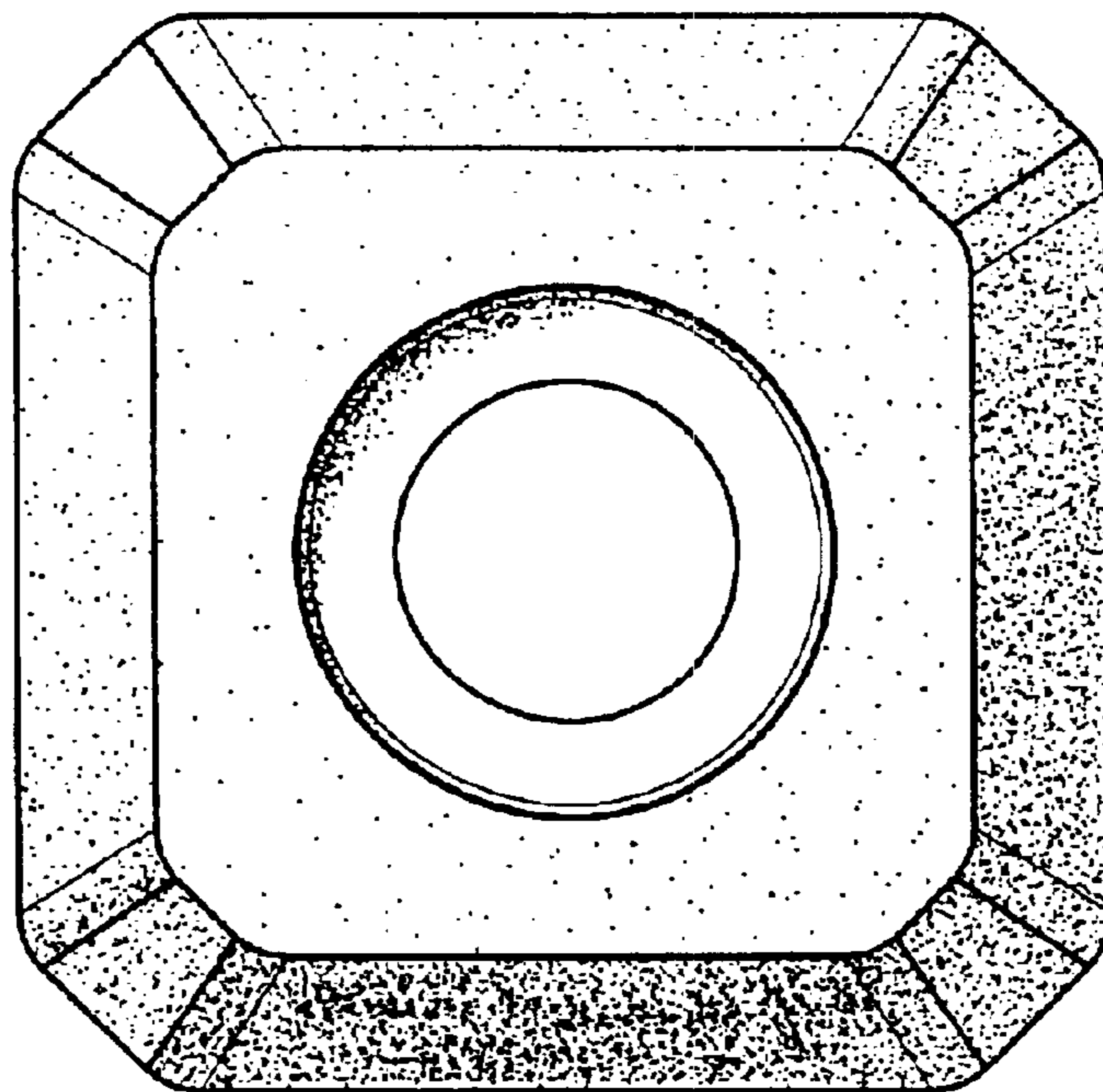

FIG. 8

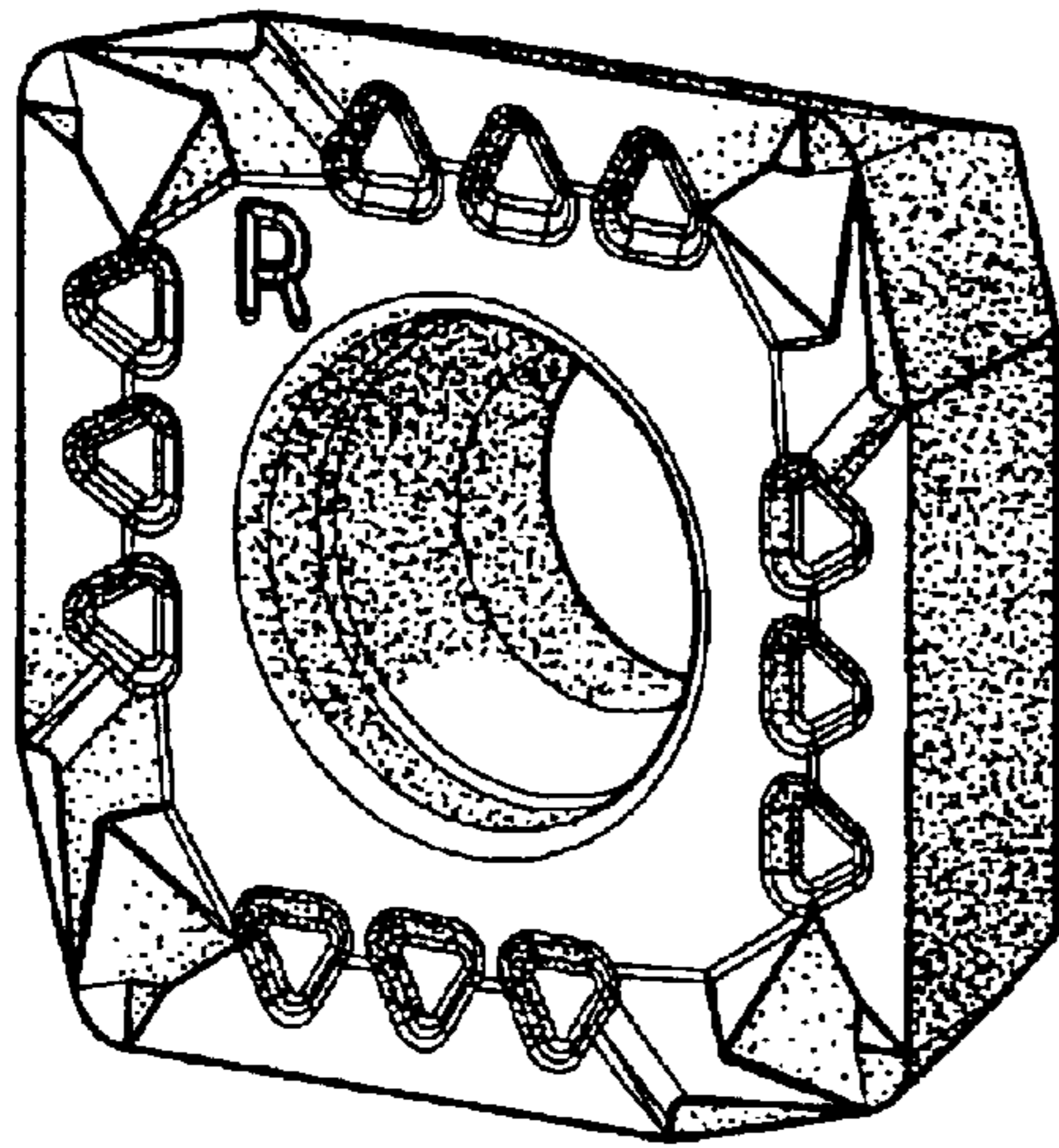

FIG. 9

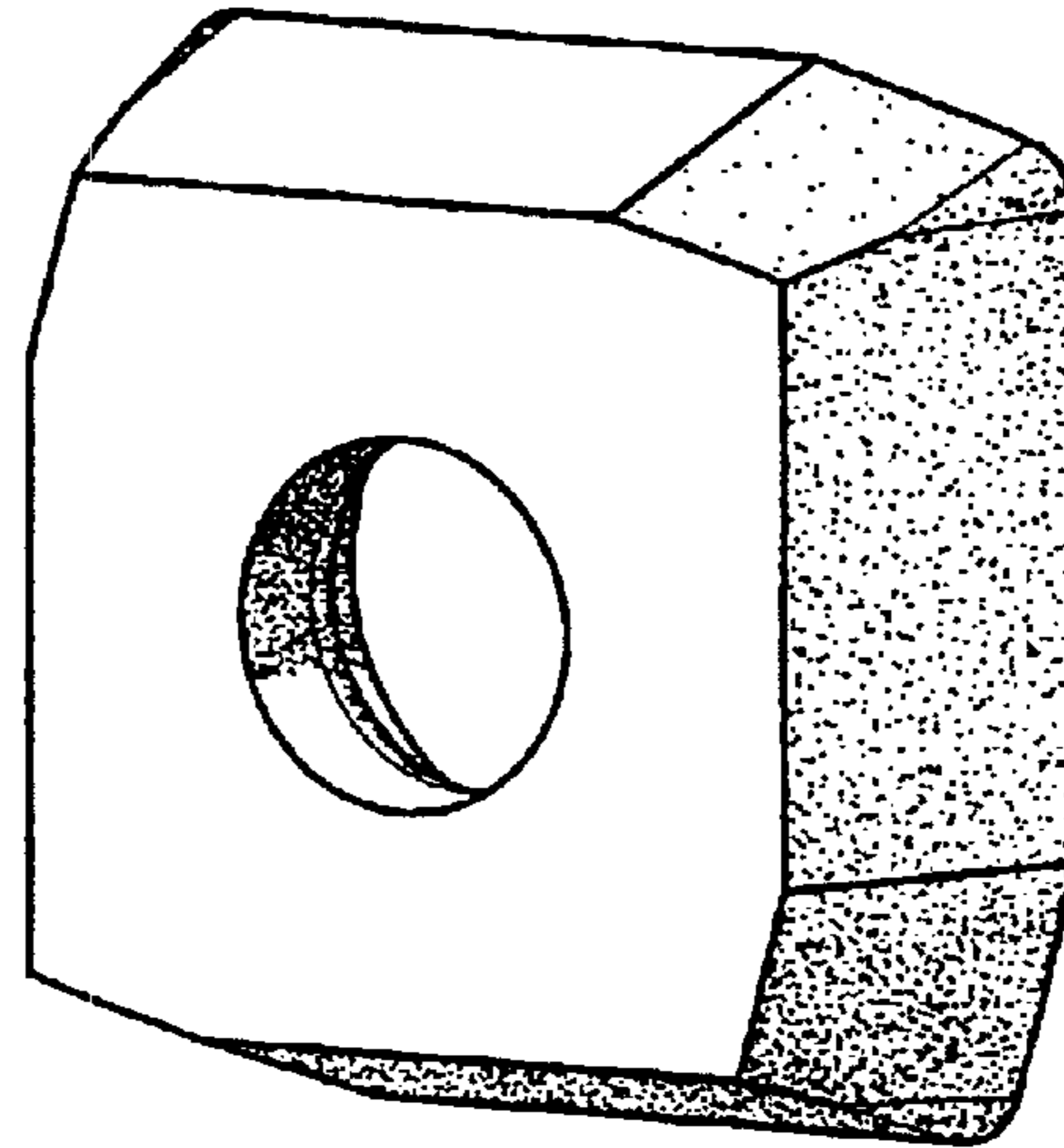

FIG. 10

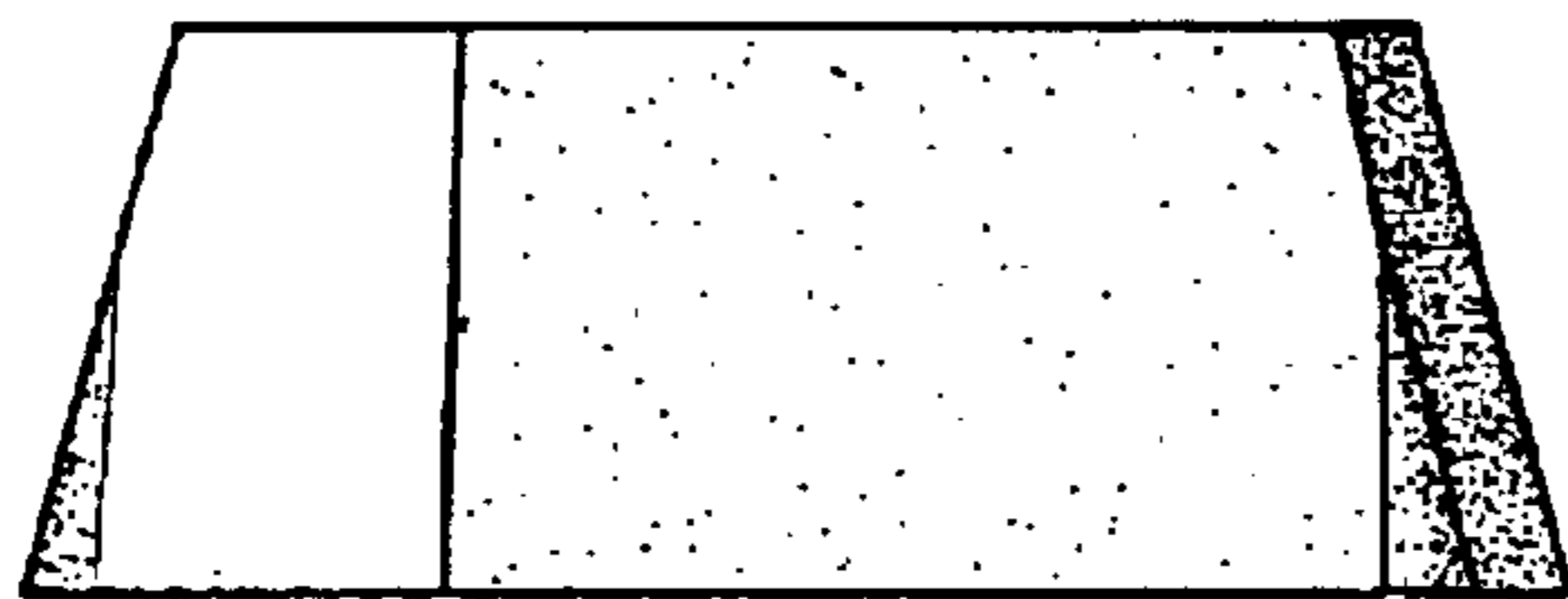

FIG. 11

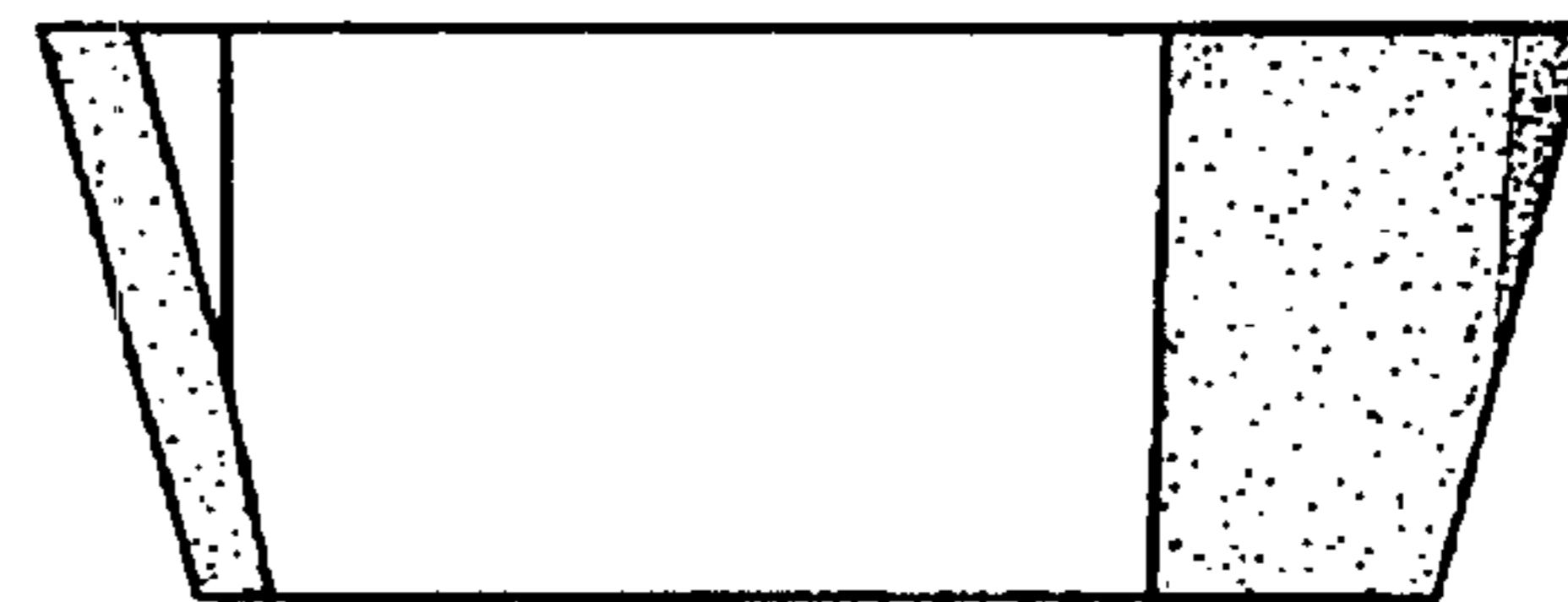

FIG. 12

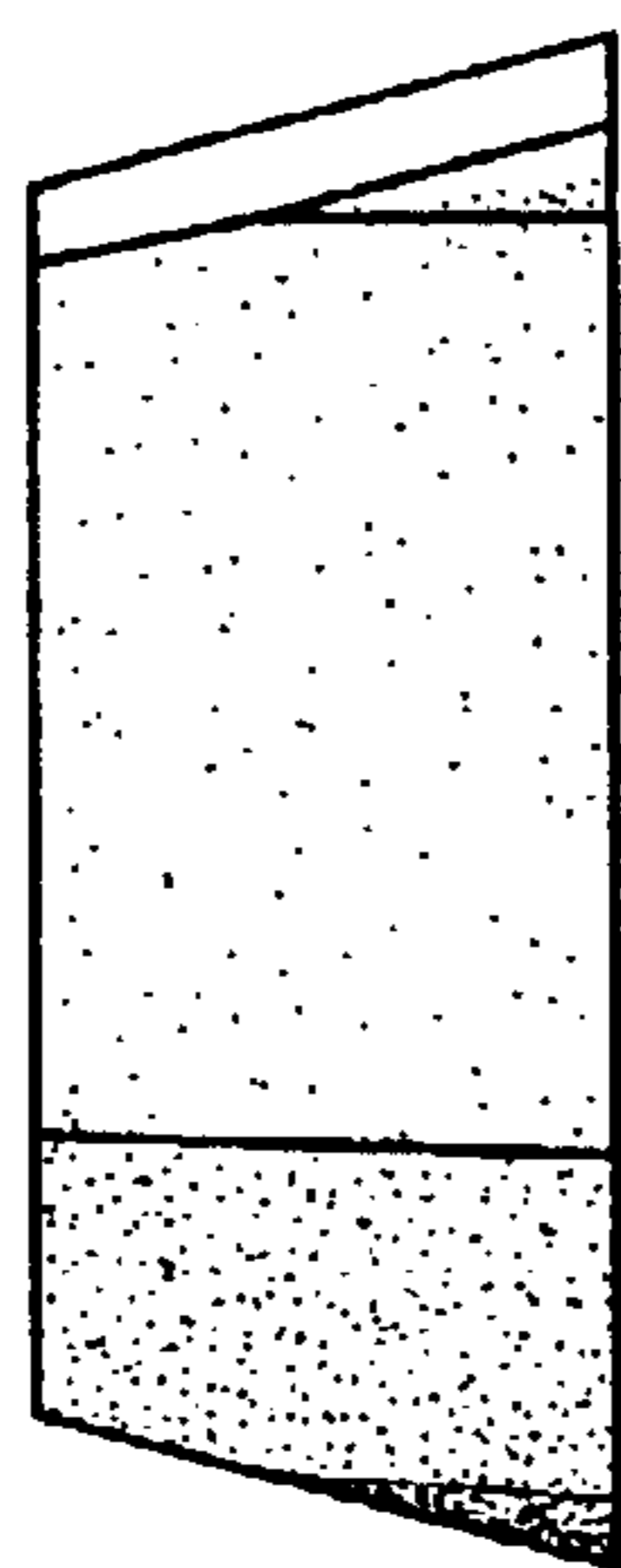

FIG. 13

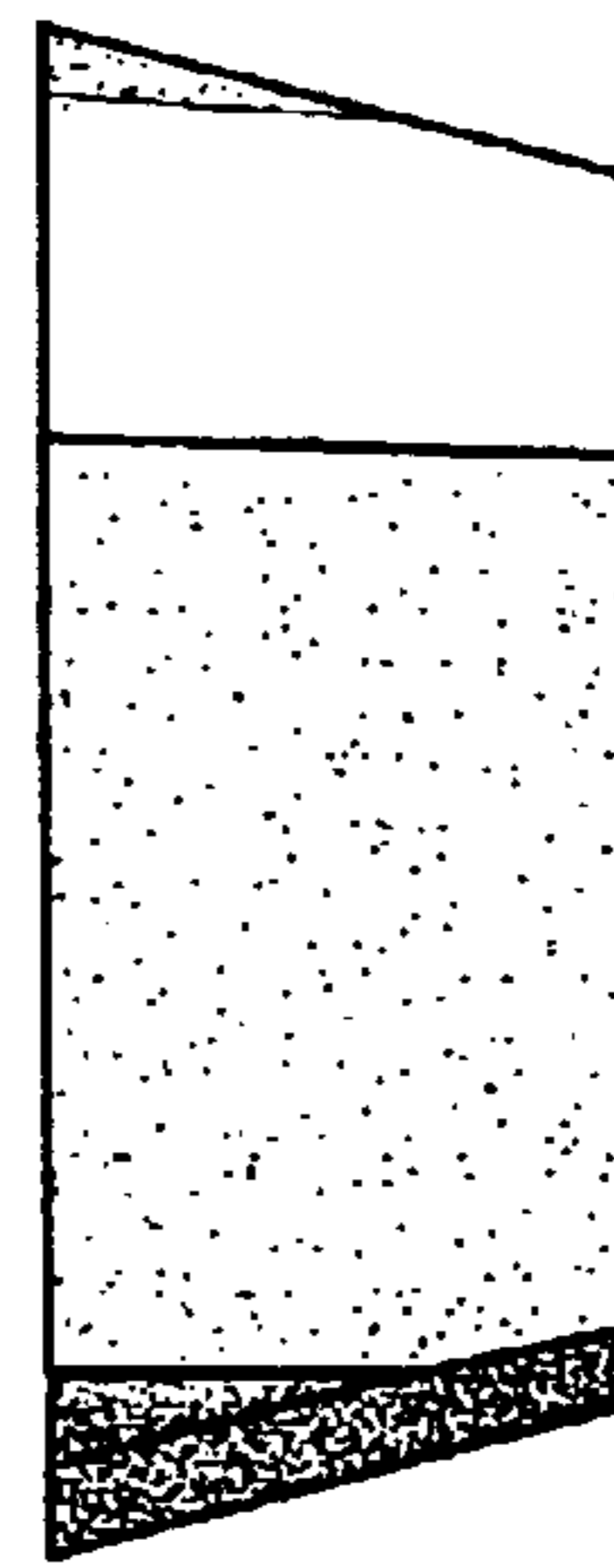

FIG. 14

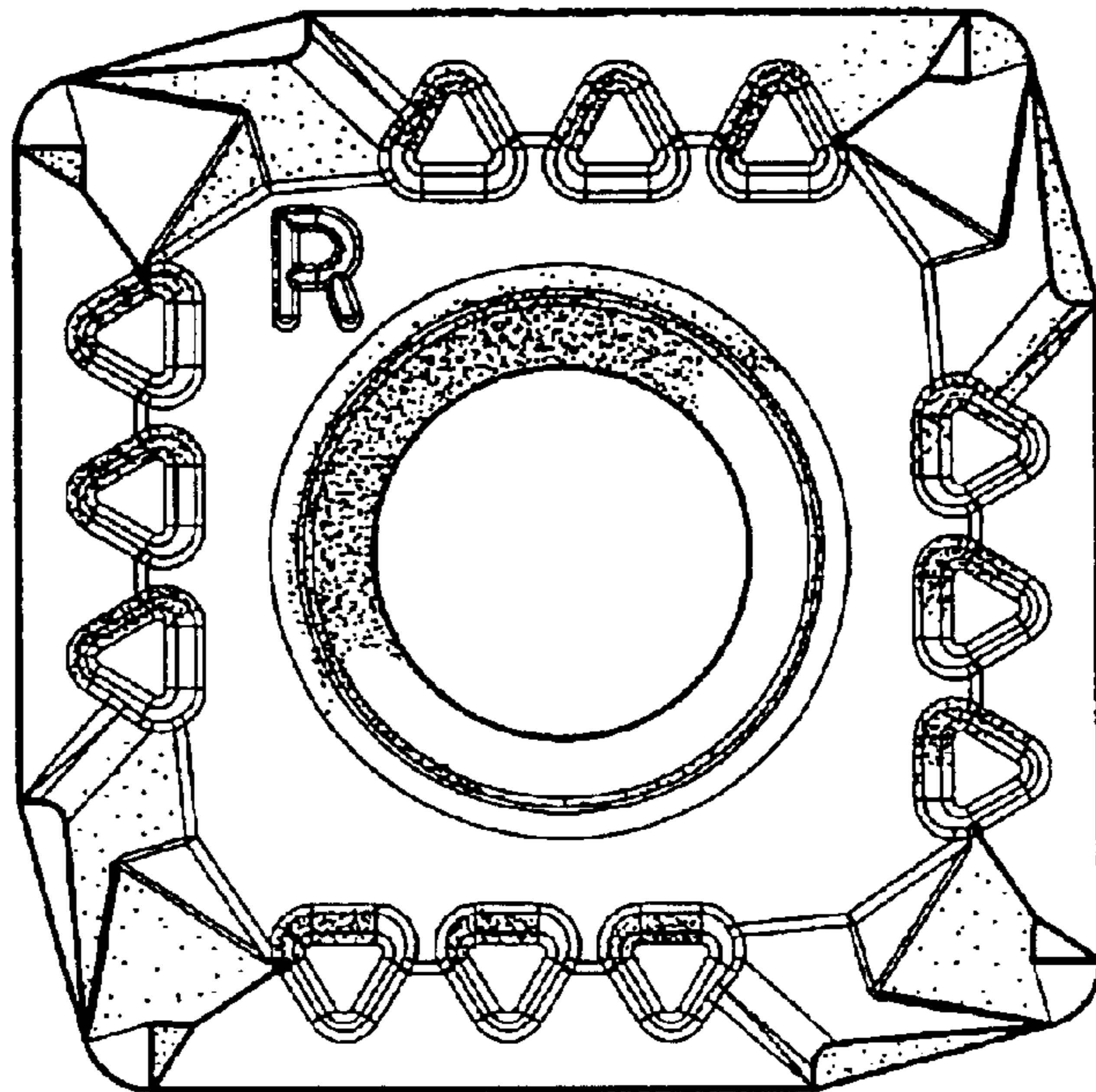

FIG. 15

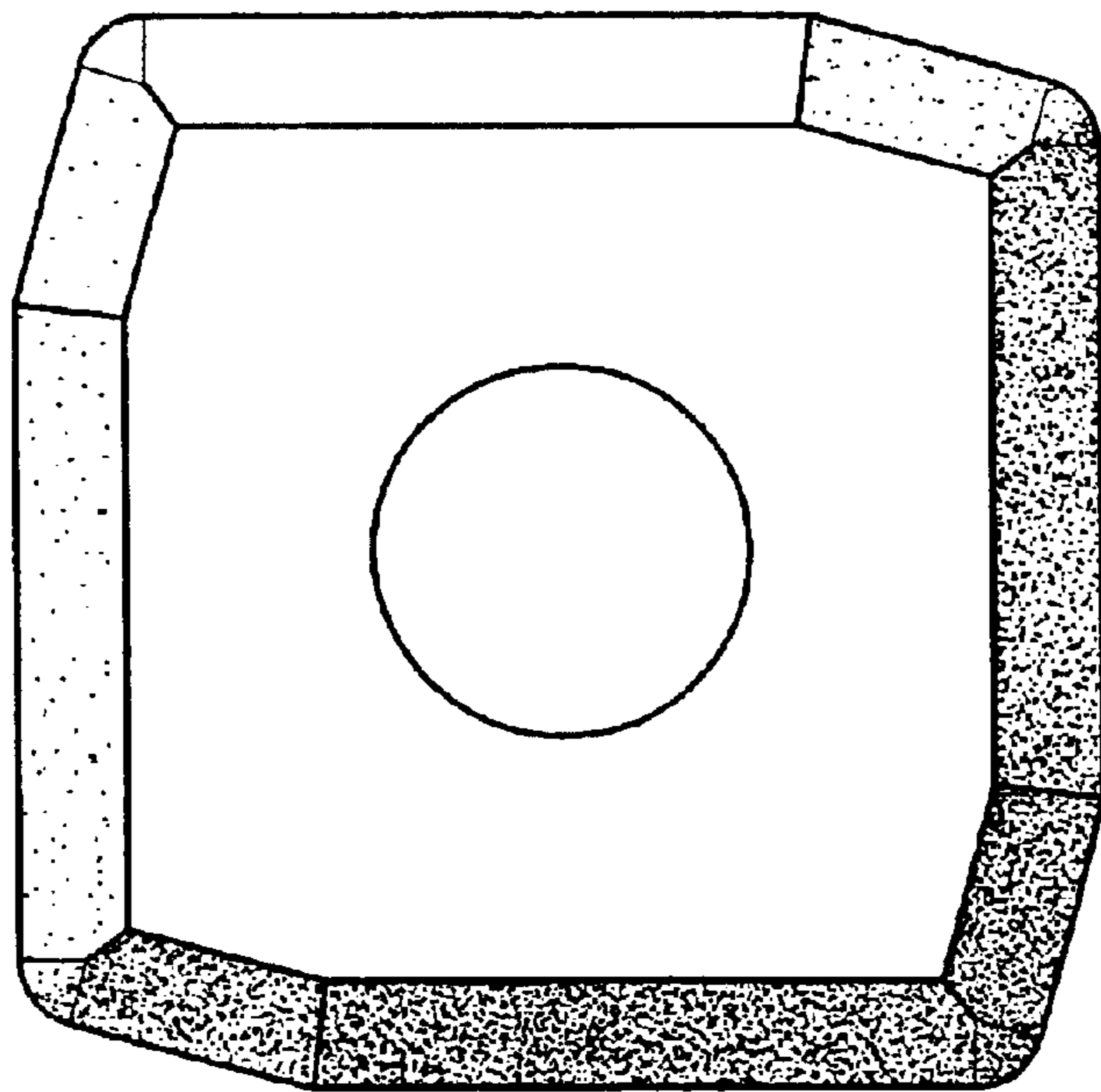

FIG. 16

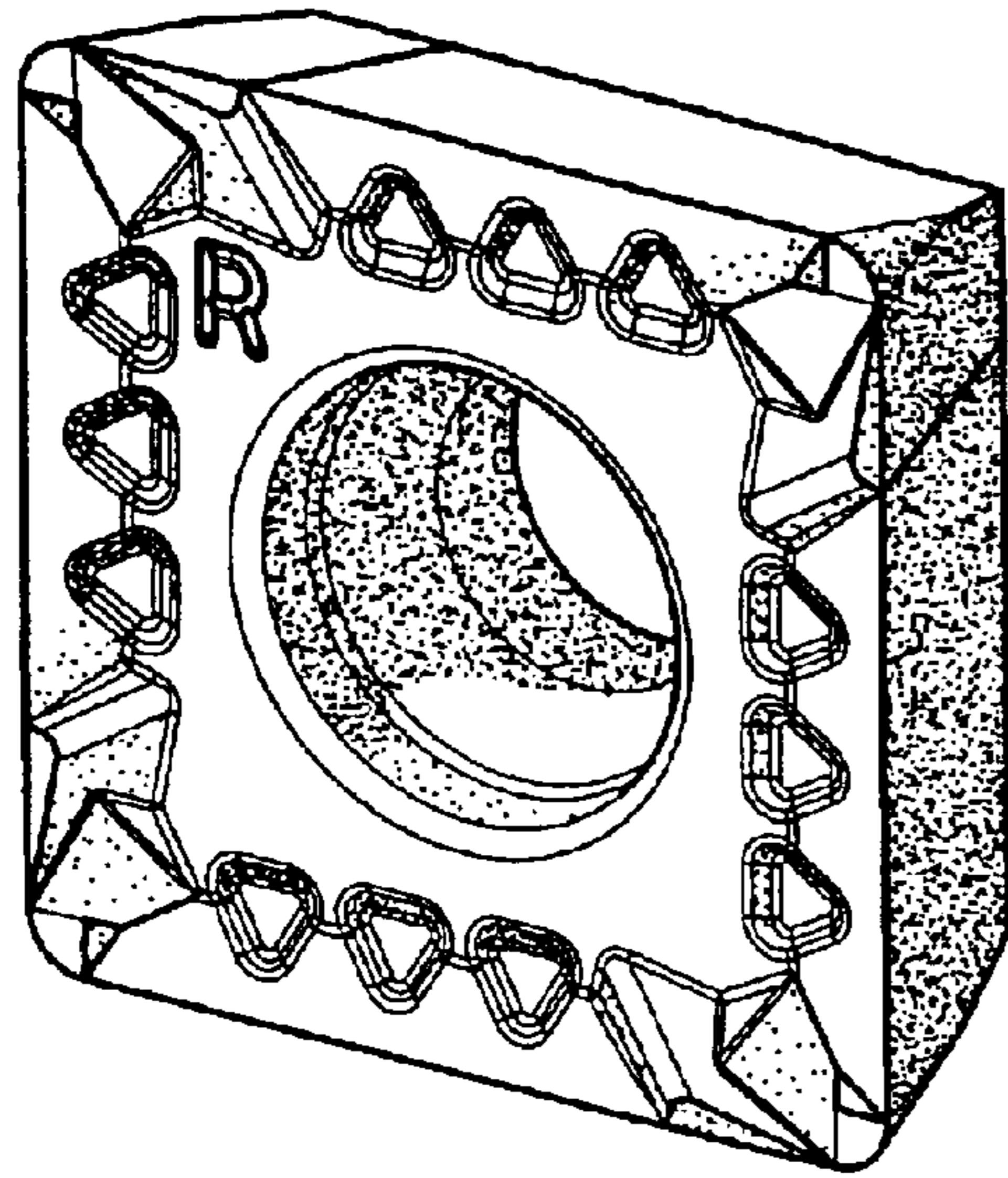

FIG. 17

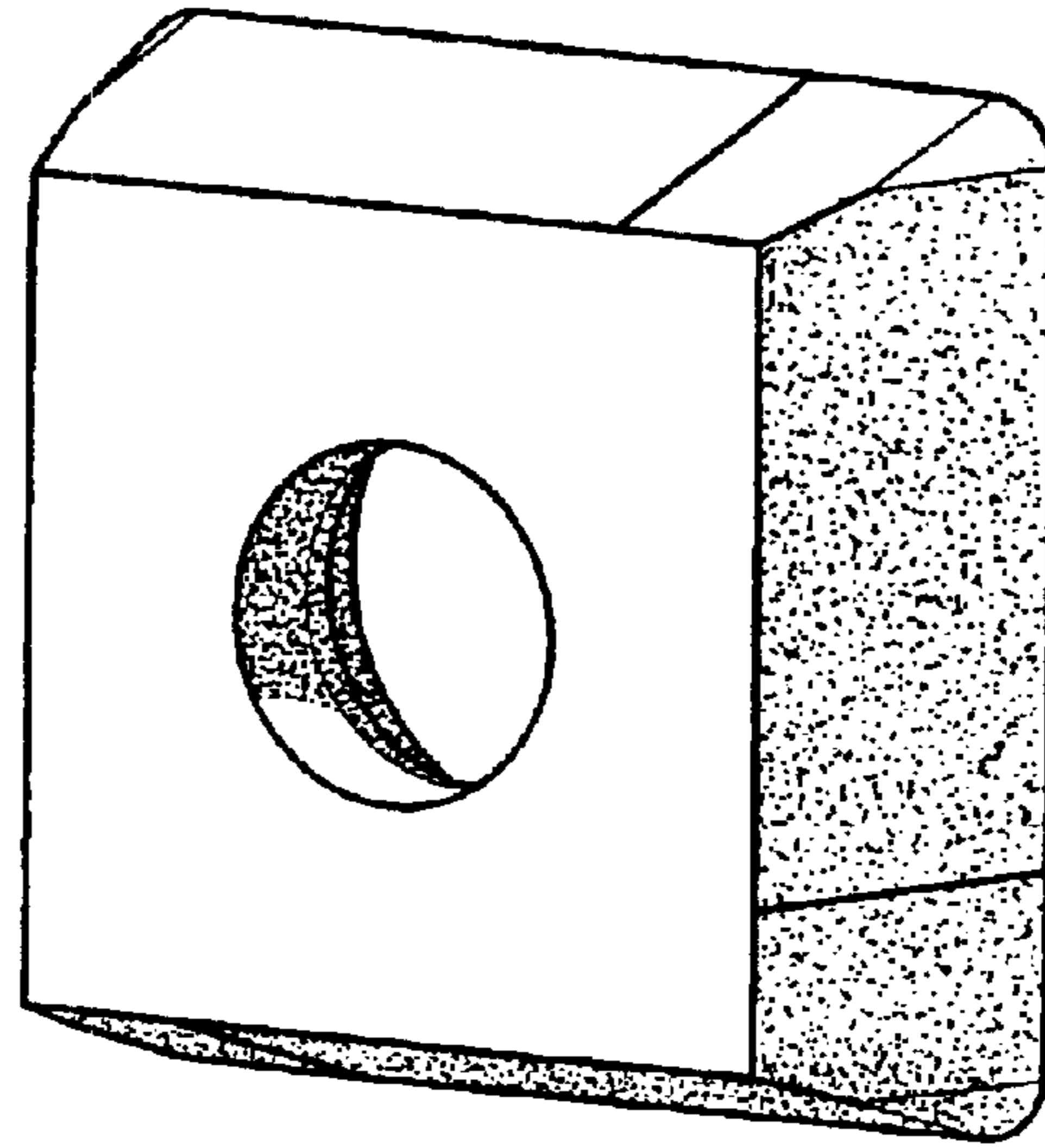

FIG. 18

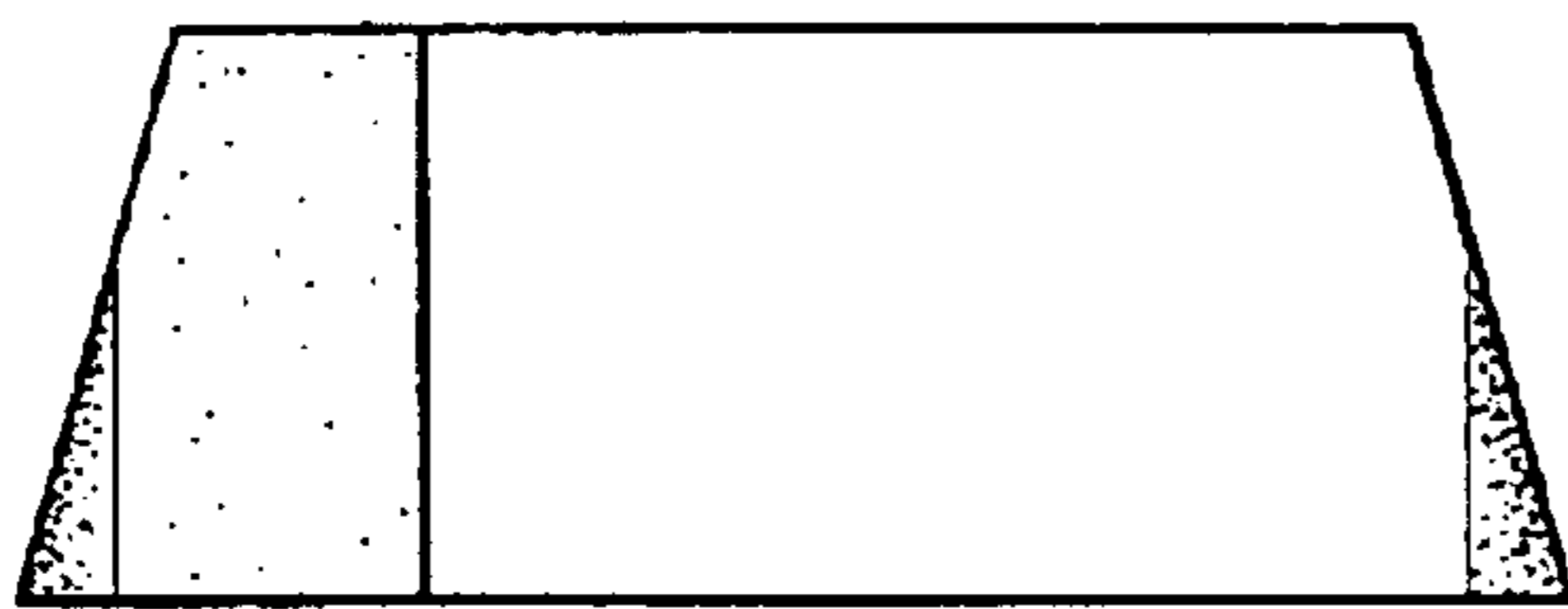

FIG. 19

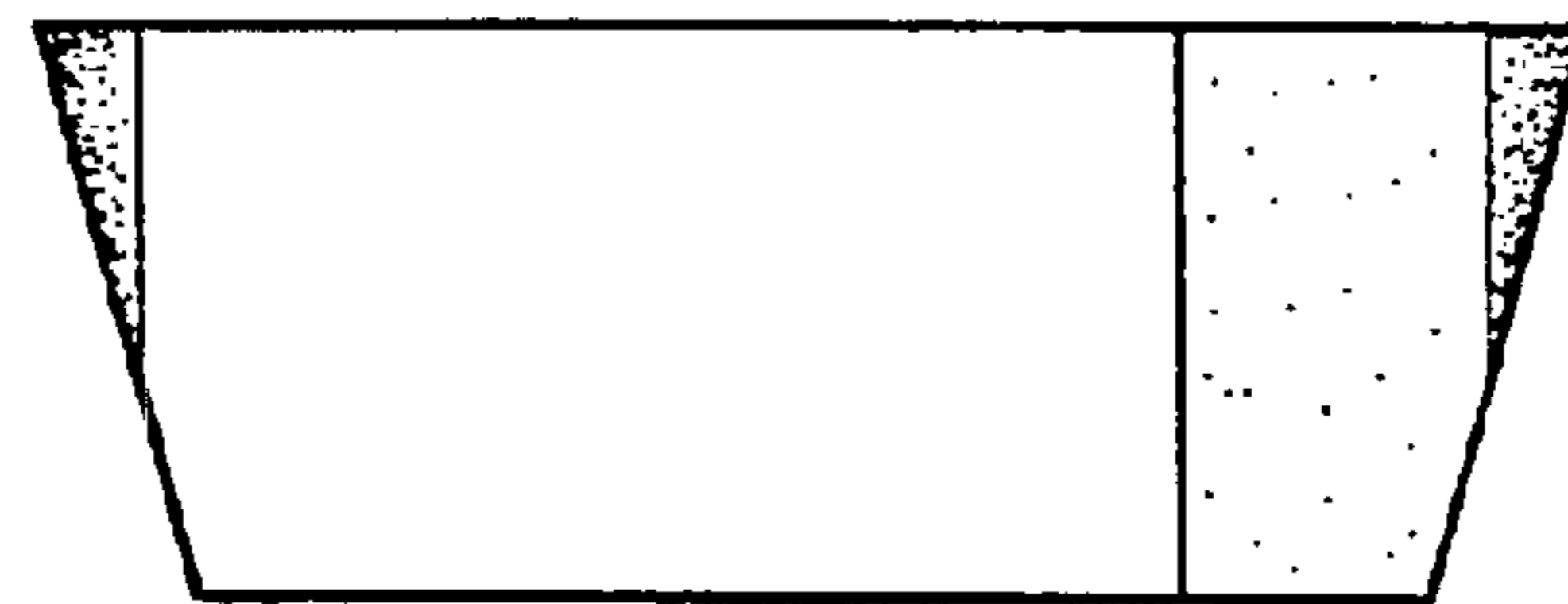

FIG. 20

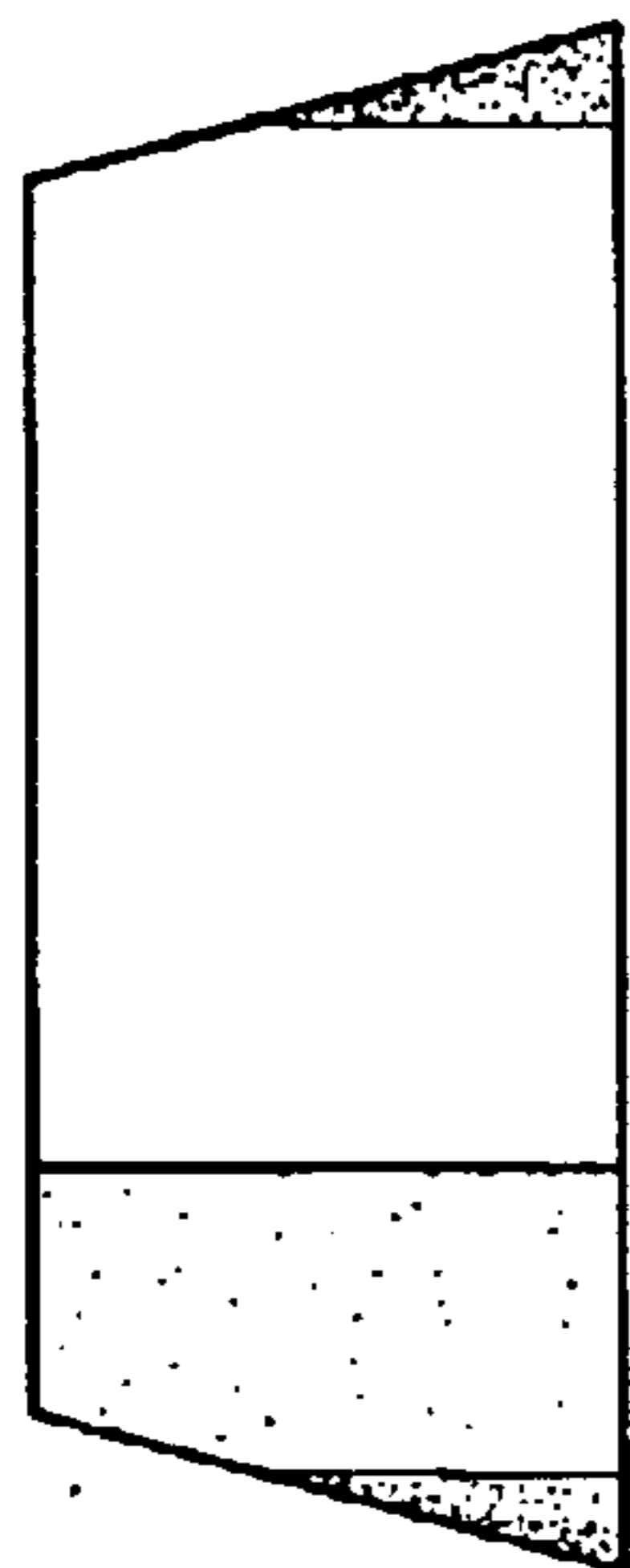

FIG. 21

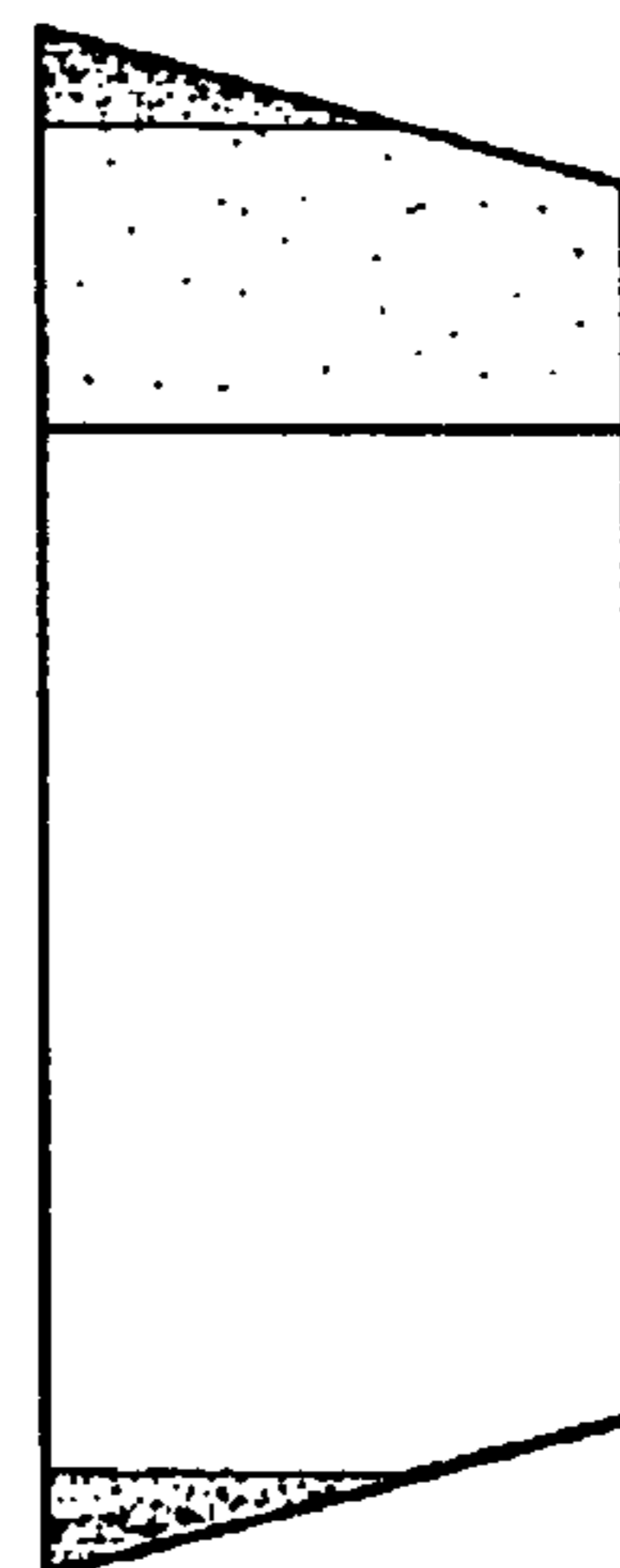

FIG. 22

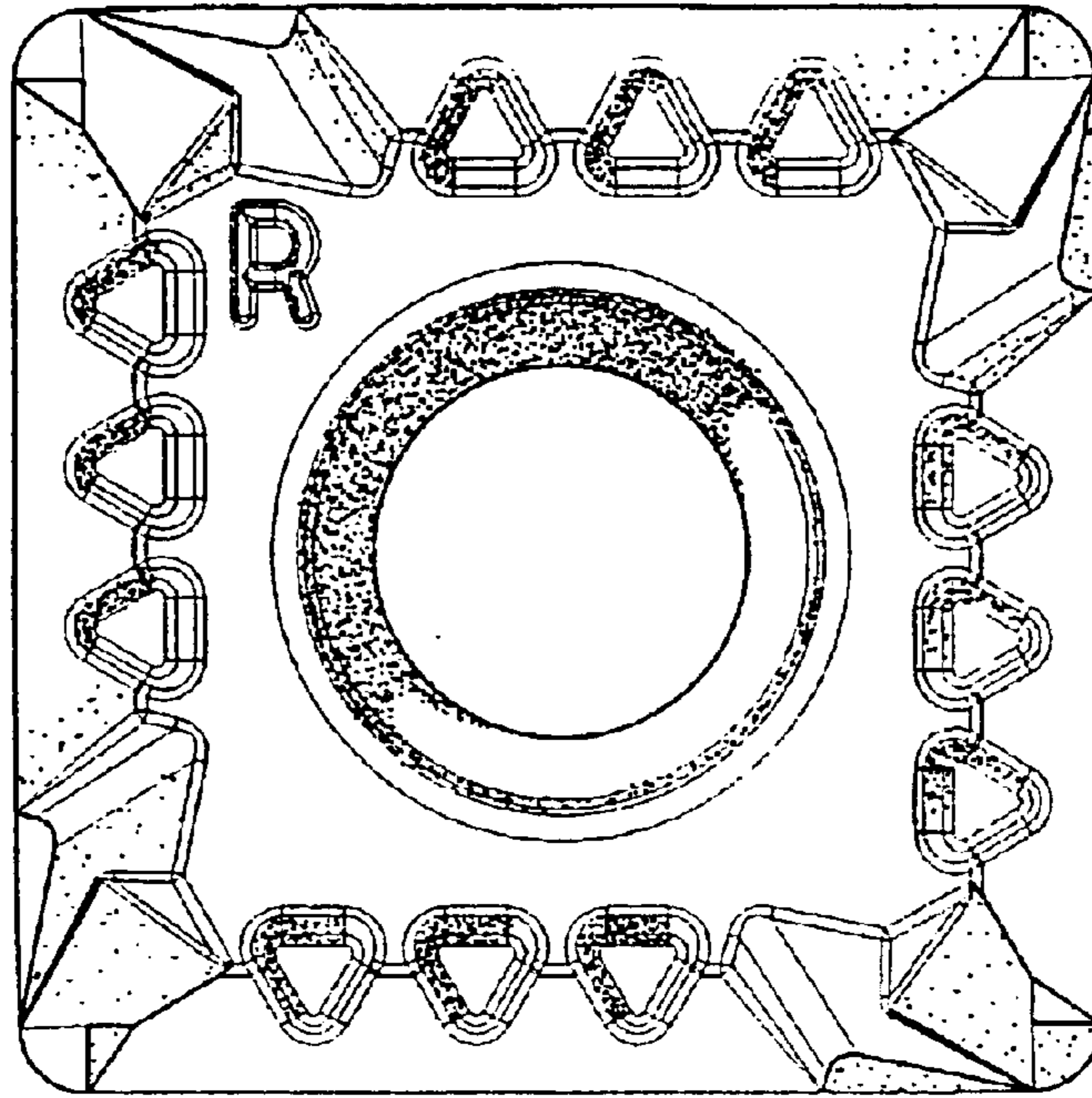

FIG. 23

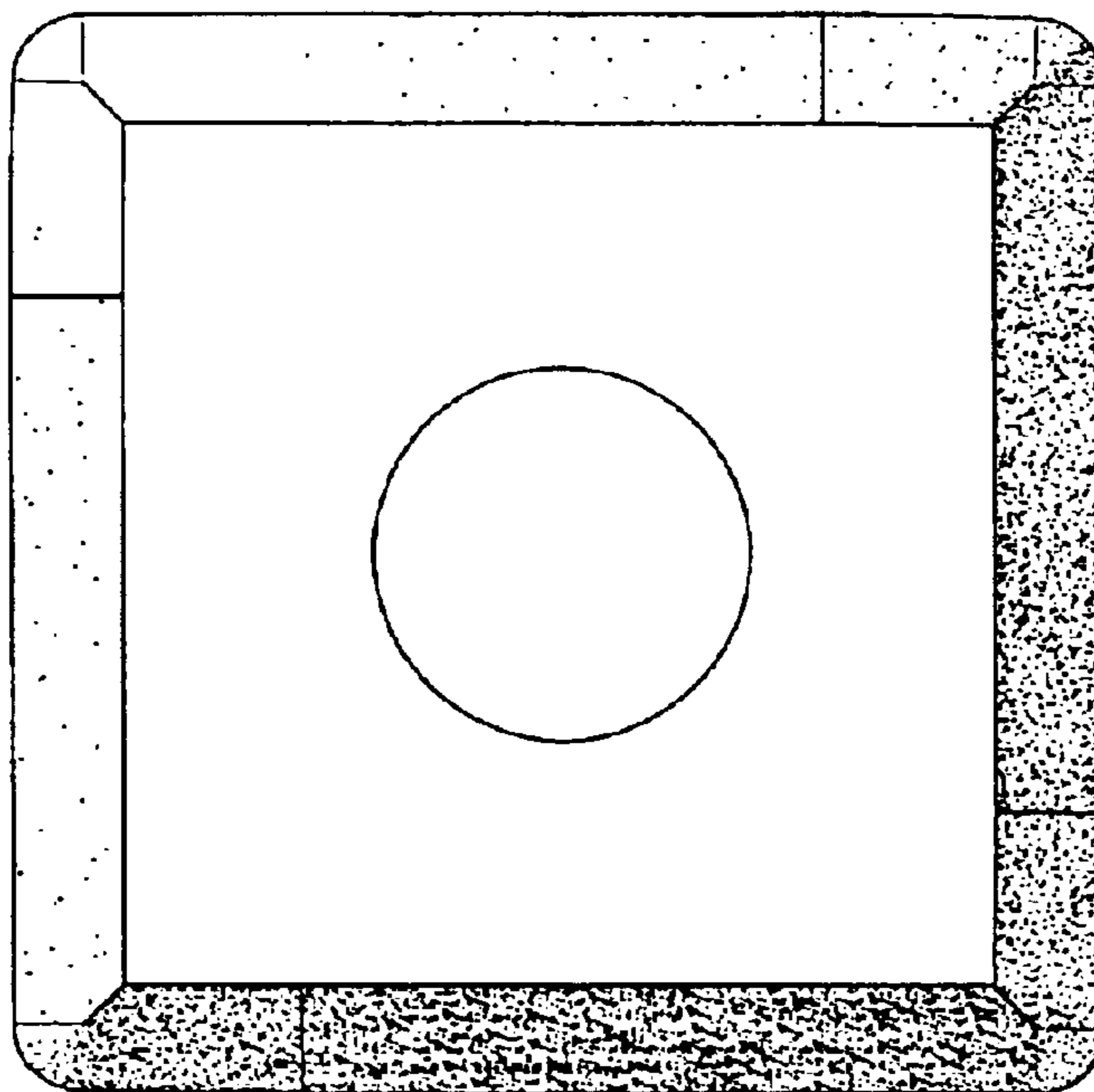

FIG. 24