

US00D497324S1

(12) **United States Design Patent** (10) **Patent No.:** **US D497,324 S**  
**Chestnut et al.** (45) **Date of Patent:** **\*\* Oct. 19, 2004**

(54) **ALL-TERRAIN UTILITY VEHICLE**

(75) Inventors: **William R. Chestnut**, Salina, KS (US);  
**Kenneth J. King**, Abilene, KS (US);  
**John P. Quinley**, Salina, KS (US);  
**Richard J. Robbins**, Derby, KS (US);  
**Daniel Selleck**, Cameron, WI (US);  
**Charles A. Weaver**, Abilene, KS (US)

(73) Assignee: **Great Plains Manufacturing Incorporated**, Salina, KS (US)

(\*\*) Term: **14 Years**

(21) Appl. No.: **29/191,931**

(22) Filed: **Oct. 16, 2003**

(51) **LOC (7) Cl.** ..... **12-14**

(52) **U.S. Cl.** ..... **D12/1; D12/16; D12/87**

(58) **Field of Search** ..... **D12/1, 14-16,**  
**D12/82-87, 107; 280/DIG. 5; 180/223,**  
**908; 296/182-186**

(56) **References Cited**

**U.S. PATENT DOCUMENTS**

D203,745 S	*	2/1966	Viftone	.....	D12/87
D221,331 S	*	8/1971	Viftone	.....	D12/87
D222,241 S	*	10/1971	Doss	.....	D12/87
D301,849 S	*	6/1989	Oba et al.	.....	D12/87
D327,237 S	*	6/1992	Miyamoto et al.	.....	D12/87
D342,701 S	*	12/1993	Murata et al.	.....	D12/107
D433,651 S	*	11/2000	Matsumura et al.	.....	D12/1
D439,548 S	*	3/2001	Kouchi et al.	.....	D12/1
D441,693 S	*	5/2001	Lessard et al.	.....	D12/107
6,626,260 B2	*	9/2003	Gagnon et al.	.....	180/291
D491,841 S	*	6/2004	Meyers	.....	D12/87

**OTHER PUBLICATIONS**

Brochure, Workmate 2100 Utility Vehicle (front and back pages).

Brochure, Polaris Ranger Off-Road Utility Vehicles, Part #9918041 Printed in U.S.A. © 2002 (front and back pages).

Brochure, Polaris Professional Series, Part #9917339 © 2002 (front and back pages).

Brochure, Gator Utility Vehicles (John Deere), DKA106(00-01) Litho in U.S.A. (16 pp.).

Brochure, Steiner Textron, 09-458 © 2002 ( 24 pgs. ).

Brochure, Raptor Utility Vehicle—Redefining the Breed (6 pgs.).

Brochure, Mule Utility Vehicles—Kawasaki © 2000, P/N 99969-2836 ( 10 pgs.).

\* cited by examiner

*Primary Examiner*—Nelson C. Holtje

(74) *Attorney, Agent, or Firm*—Hovey Williams LLP

(57) **CLAIM**

The ornamental design for an all-terrain utility vehicle, as shown and described.

**DESCRIPTION**

FIG. 1 is a right front perspective view of an all terrain utility vehicle embodying our design in accordance with the present invention, the broken lines indicating environmental structure not forming a part of our design;

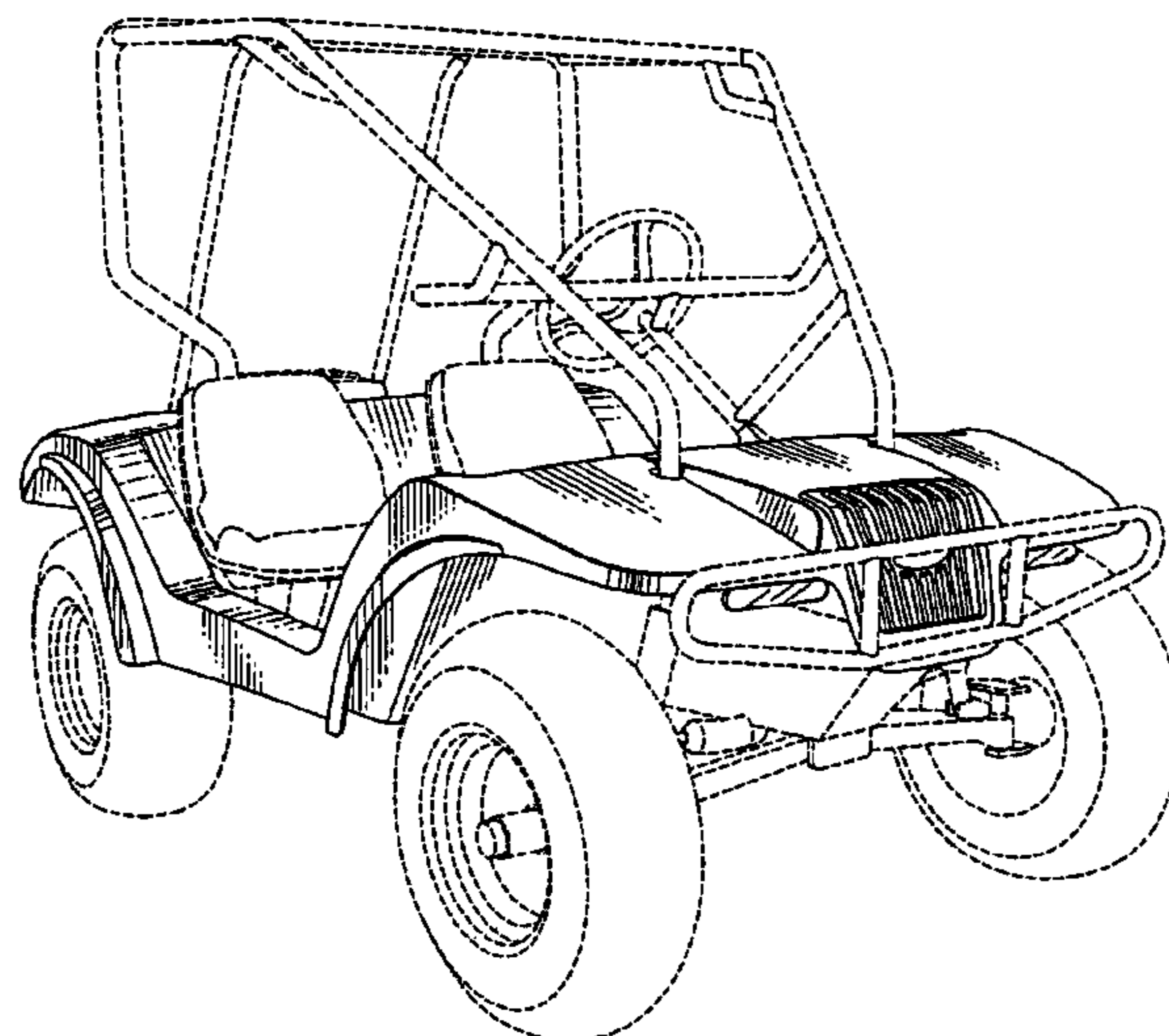
FIG. 2 is a right side perspective view thereof, the broken lines indicating environmental structure not forming a part of our design;

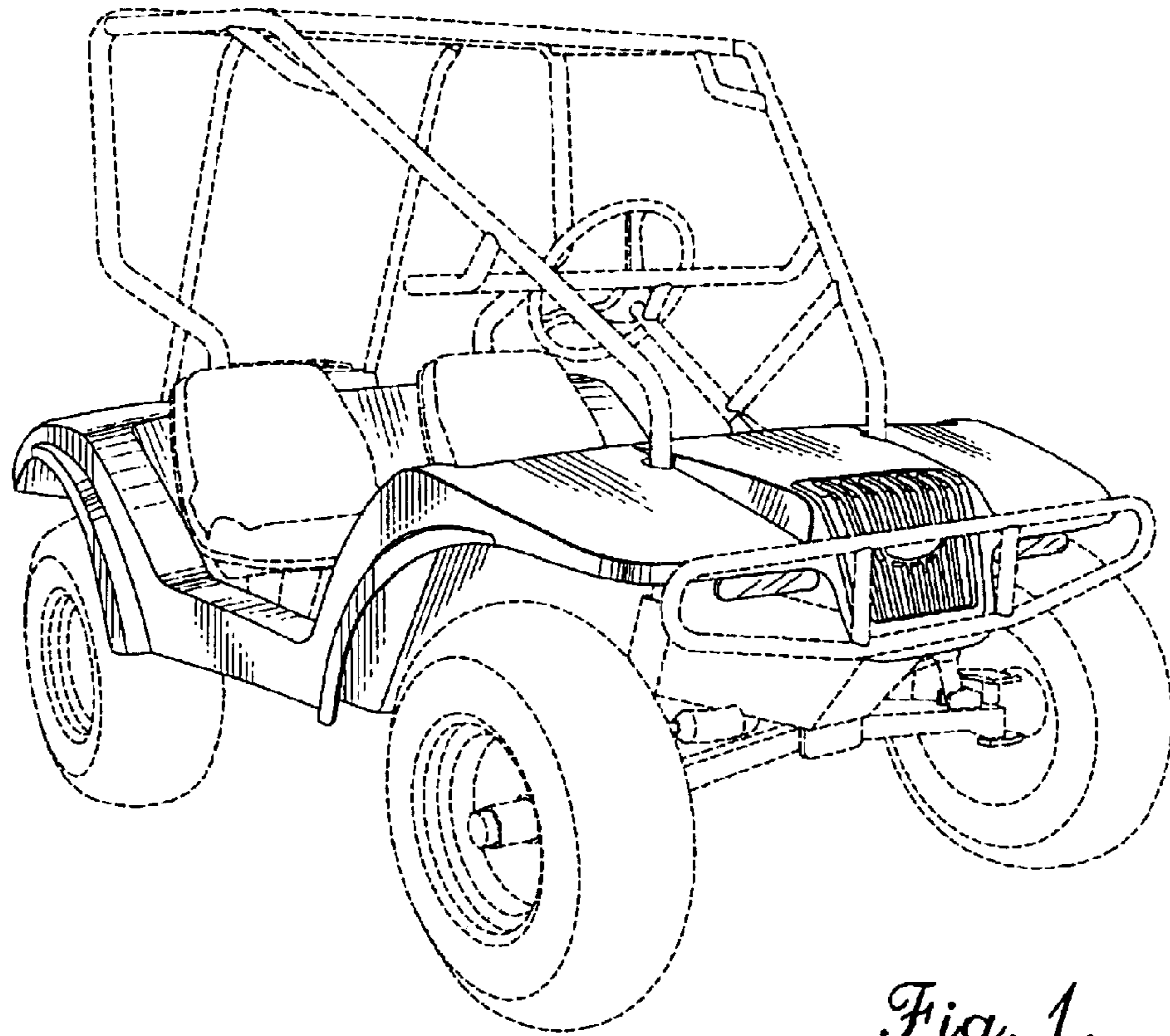
FIG. 3 is a front perspective view thereof, the broken lines indicating environmental structure not forming a part of our design;

FIG. 4 is a rear perspective view thereof, the broken lines indicating environmental structure not forming a part of our design; and,

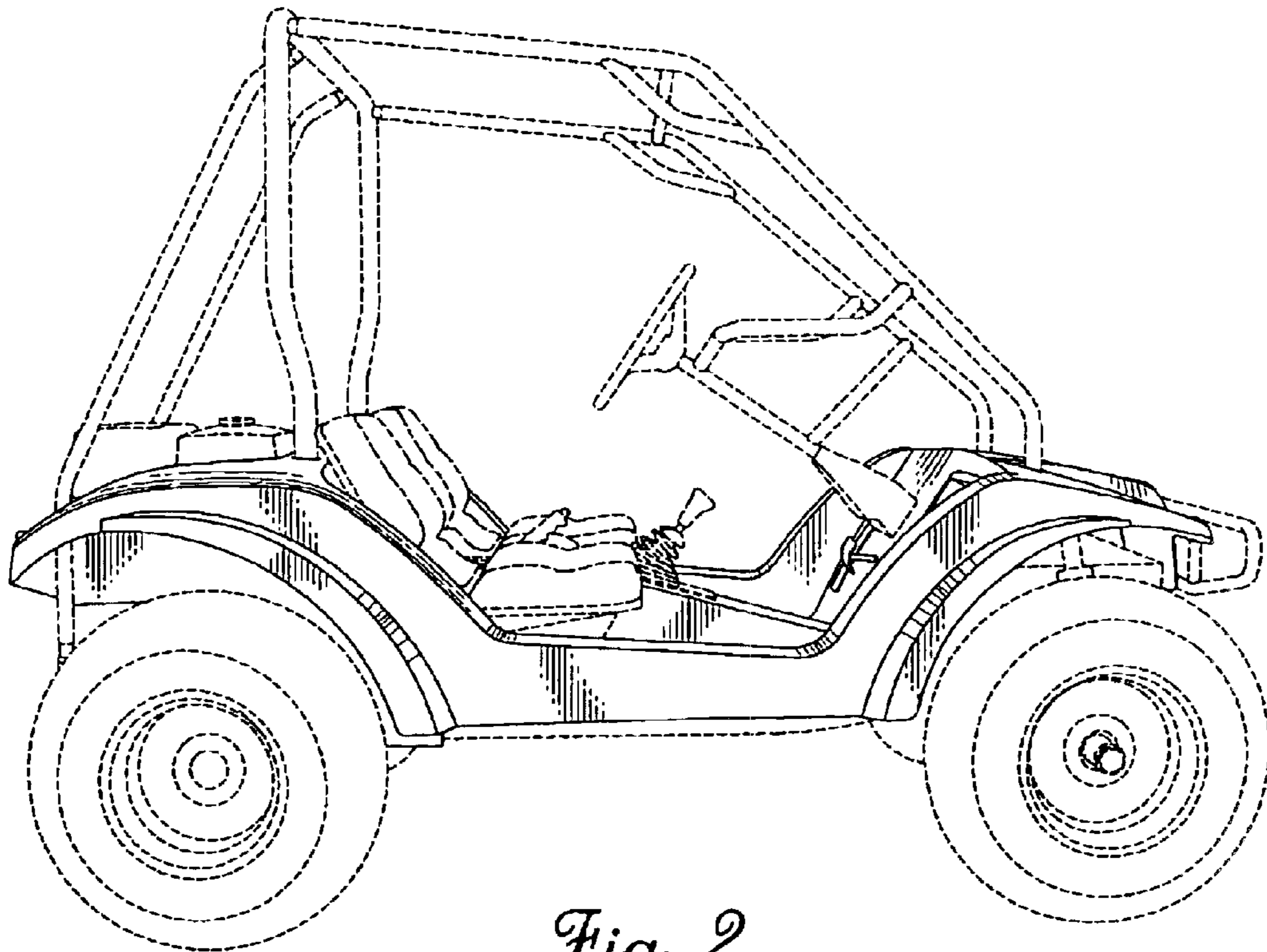
FIG. 5 is a top perspective view thereof, the broken lines indicating environmental structure not forming a part of our design.

**1 Claim, 3 Drawing Sheets**

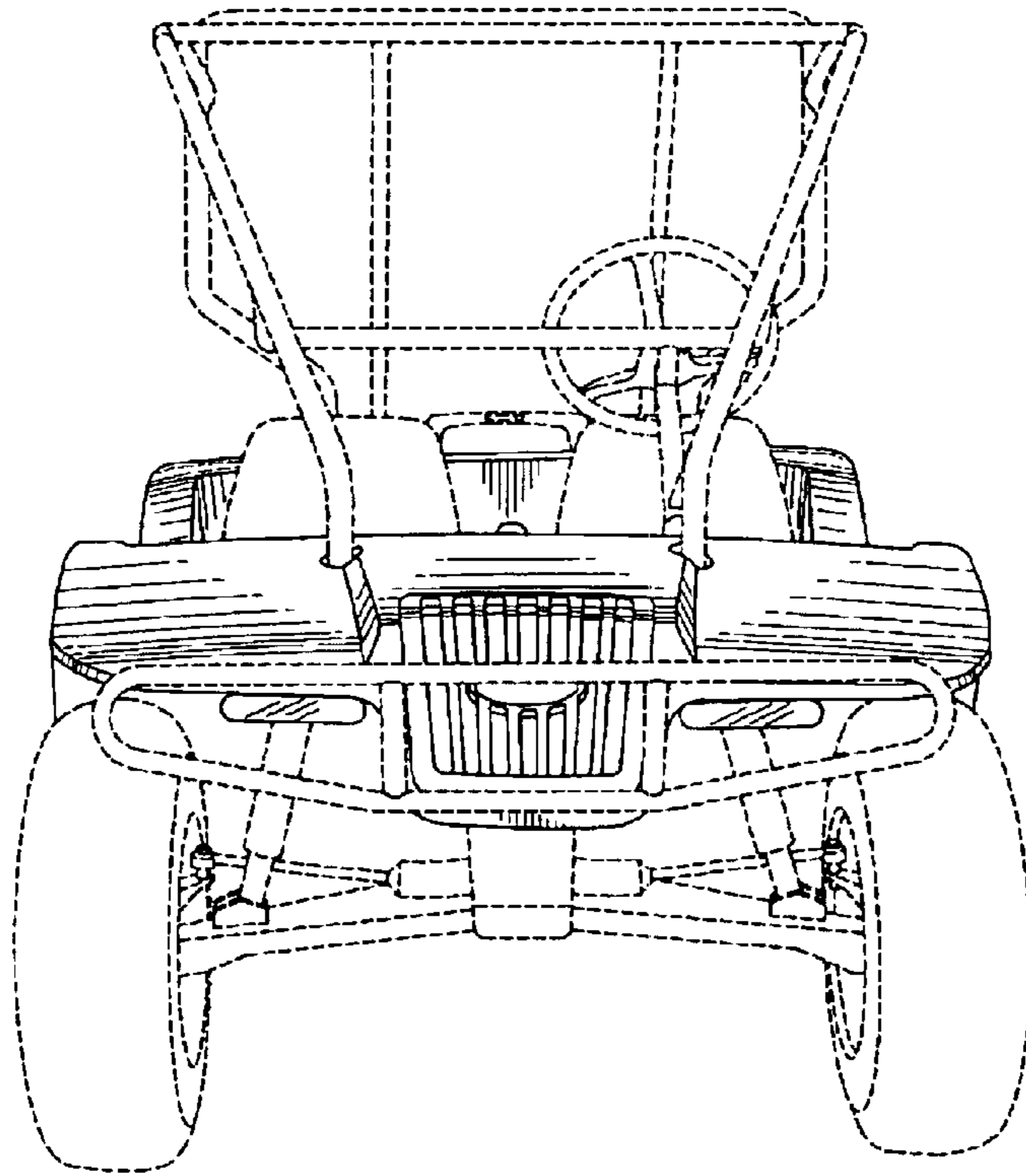




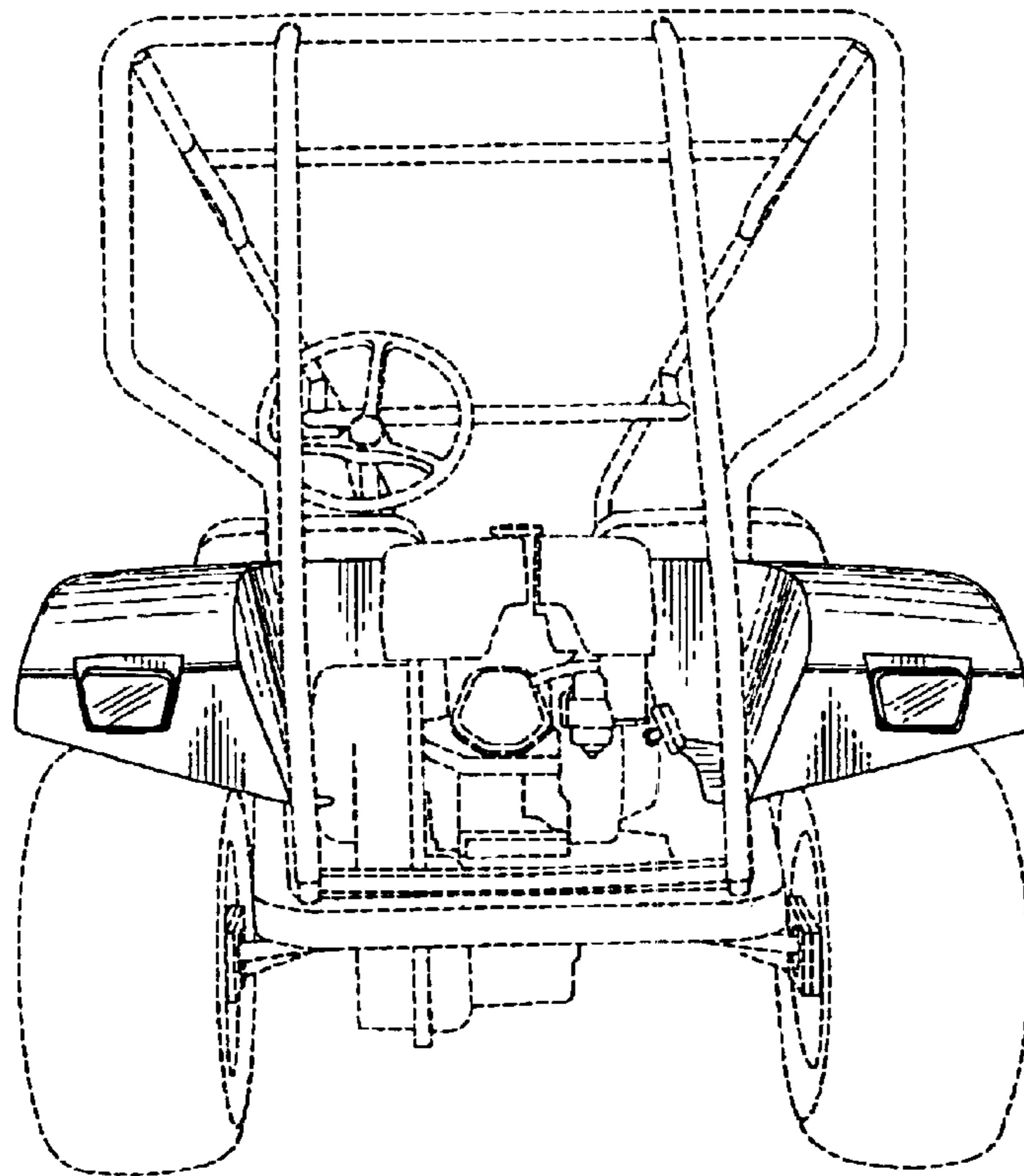
*Fig. 1.*



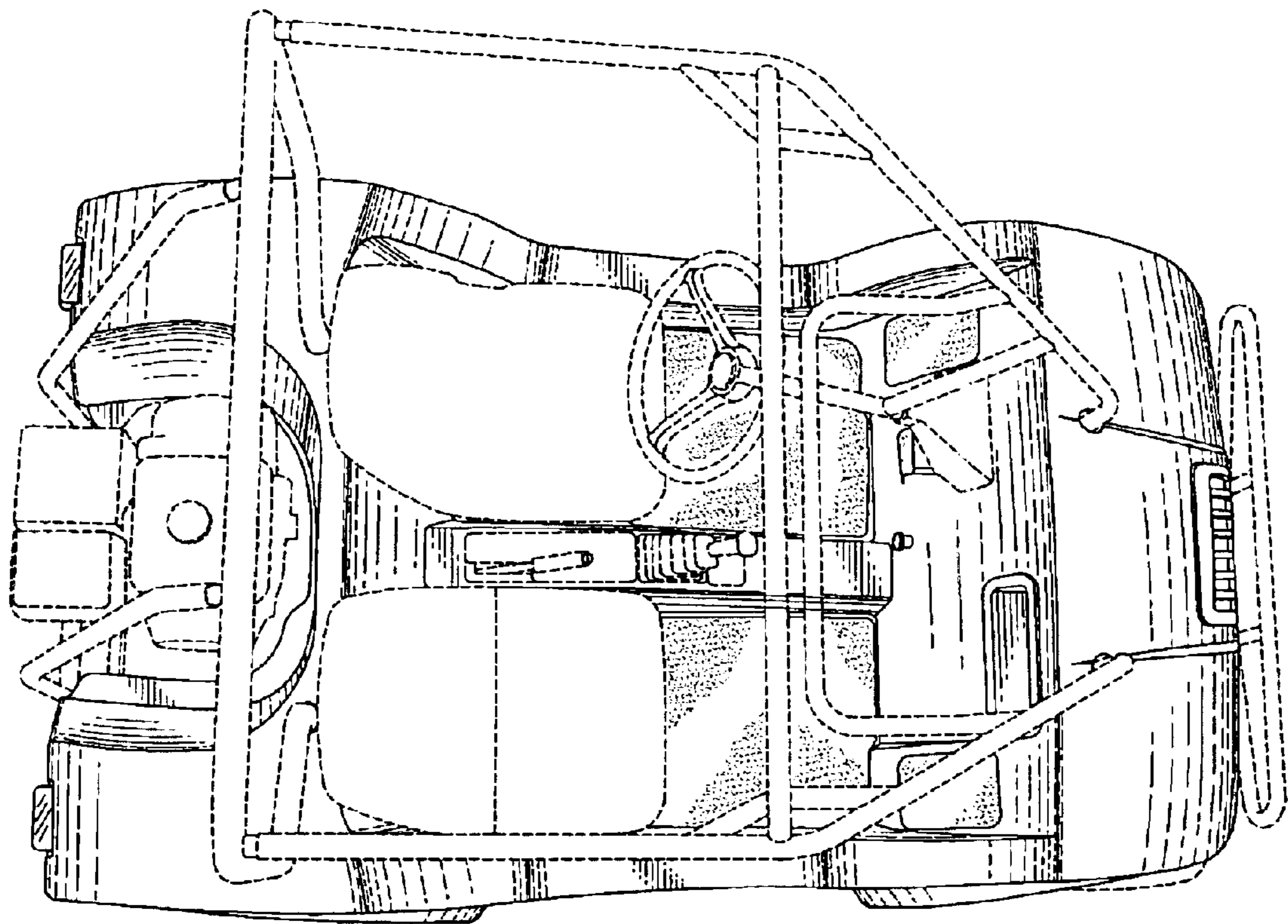
*Fig. 2.*



*Fig. 3.*



*Fig. 4.*



*Fig. 5.*