

US00D497299S1

(12) **United States Design Patent**
Matsuoka et al.

(10) **Patent No.:** **US D497,299 S**
(45) **Date of Patent:** **** Oct. 19, 2004**

(54) **PORTABLE GAS NAILING MACHINE**

(75) Inventors: **Takeshi Matsuoka**, Hitachinaka (JP);
Yoshitaka Akiba, Hitachinaka (JP);
Shoichi Hirai, Hitachinaka (JP)

(73) Assignee: **Hitachi Koki Co., Ltd.**, Tokyo (JP)

(**) Term: **14 Years**

(21) Appl. No.: **29/200,792**

(22) Filed: **Mar. 5, 2004**

(30) **Foreign Application Priority Data**

Jan. 27, 2004 (JP) 2004-001899

(51) **LOC (7) Cl.** **08-05**

(52) **U.S. Cl.** **D8/69**

(58) **Field of Search** D8/14.1, 61, 62,
D8/63, 64, 65, 66, 67, 68, 69, 70; 81/57.11,
429, 464, 465, 466, 469, 489; 173/13, 169,
178, 213, 217; 227/8, 114, 120, 130, 136,
142; 310/50; 408/20, 124, 125, 234, 241 R;
451/356

(56) **References Cited**

U.S. PATENT DOCUMENTS

D332,561 S * 1/1993 Fushiya et al. D8/69
D416,182 S * 11/1999 Kaiser et al. D8/69
D416,775 S * 11/1999 Hwang et al. D8/69

D432,882 S * 10/2000 Matsuoka et al. D8/68
D472,780 S * 4/2003 Matsuoka et al. D8/68
D477,206 S * 7/2003 Sakai et al. D8/69
6,592,014 B2 * 7/2003 Smolinski 227/8
D477,976 S * 8/2003 Liu D8/69
D481,279 S * 10/2003 Buck D8/69
D483,240 S * 12/2003 Garvis et al. D8/68
D484,385 S * 12/2003 Sakai et al. D8/68
D486,048 S * 2/2004 Hattori D8/69
2003/0230622 A1 * 12/2003 Rotharmel 227/120

* cited by examiner

Primary Examiner—Joel Sincavage

Assistant Examiner—T. Chase Nelson

(74) *Attorney, Agent, or Firm*—Sughrue Mion, PLLC

(57) **CLAIM**

The ornamental design for a portable gas nailing machine, as shown.

DESCRIPTION

FIG. 1 is a perspective view of the top, front and right side of a portable gas nailing machine showing our new design; FIG. 2 is a right side elevational view thereof; FIG. 3 is a left side elevational view thereof; FIG. 4 is a front elevational view thereof; FIG. 5 is a rear elevational view thereof; FIG. 6 is a top plan view thereof; and, FIG. 7 is a bottom plan view thereof.

1 Claim, 5 Drawing Sheets

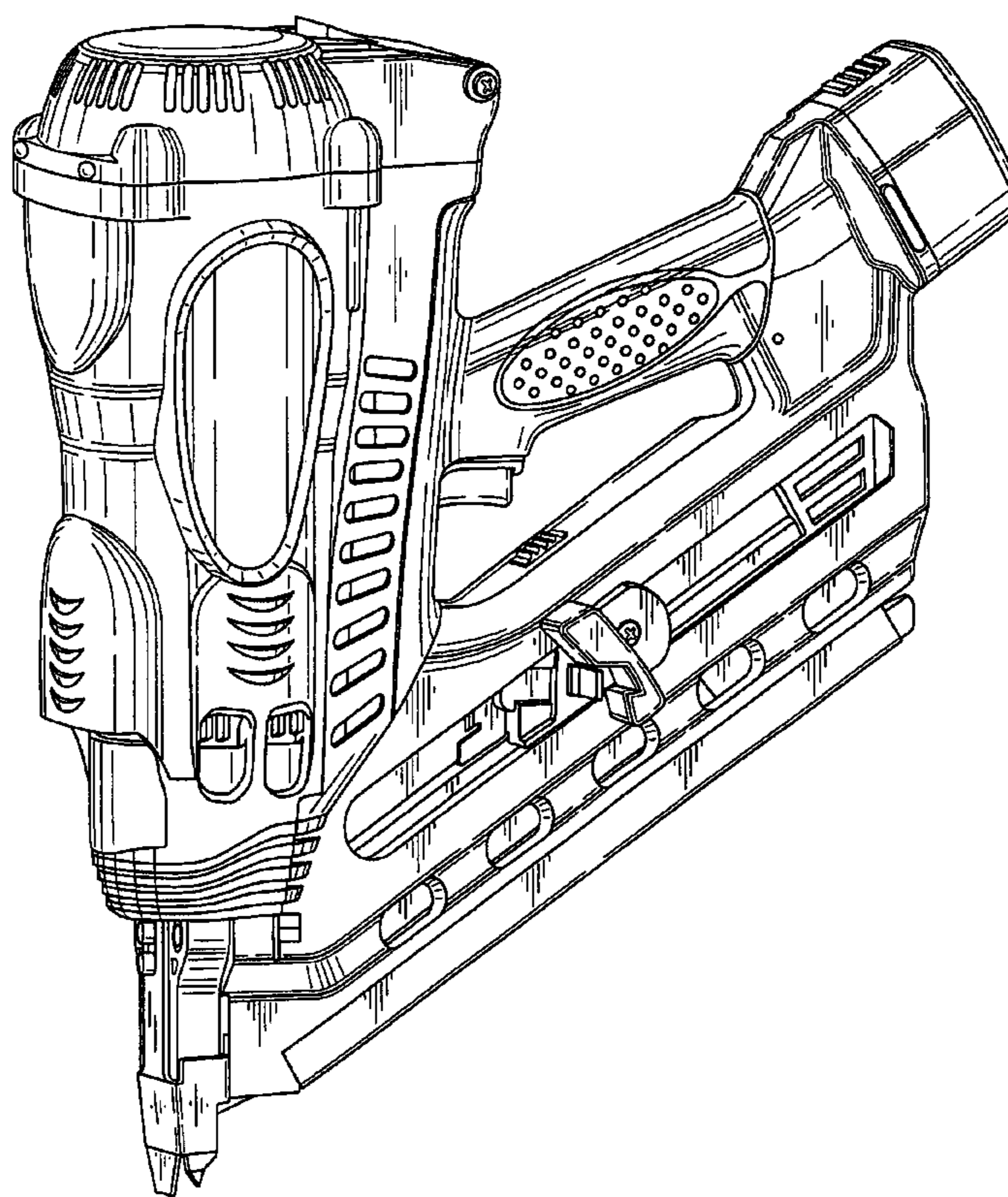

FIG. 1

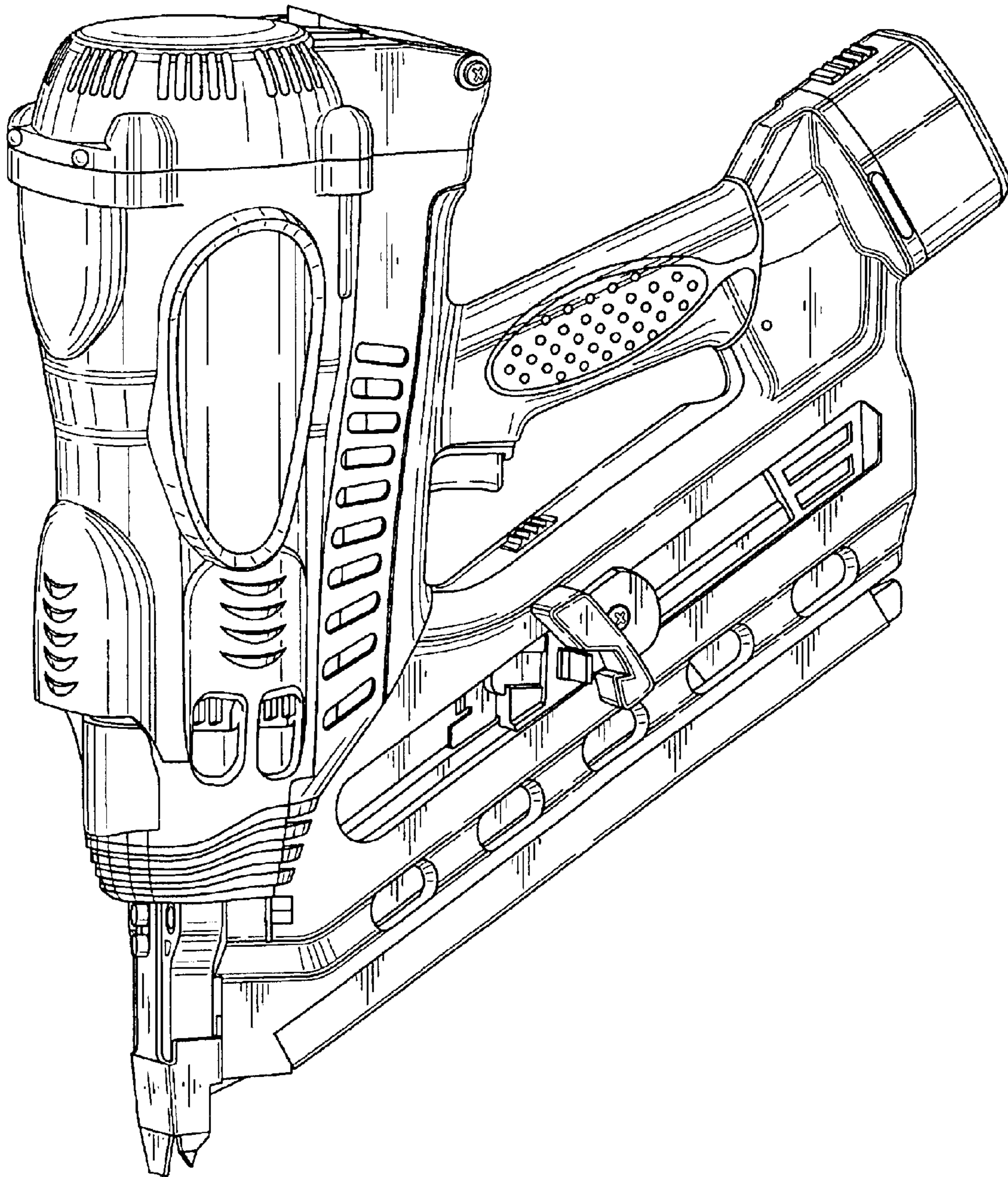

FIG. 2

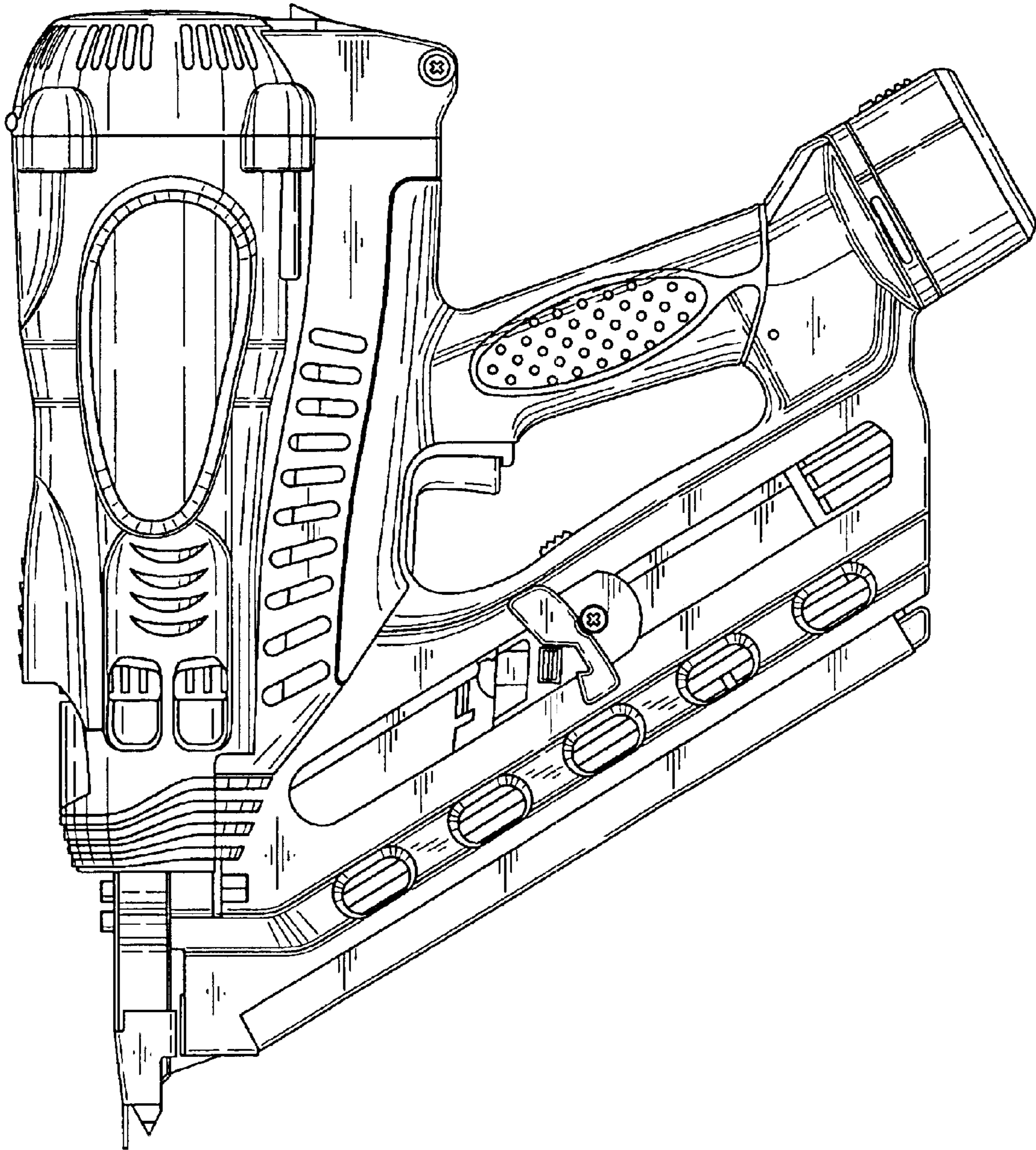

FIG. 3

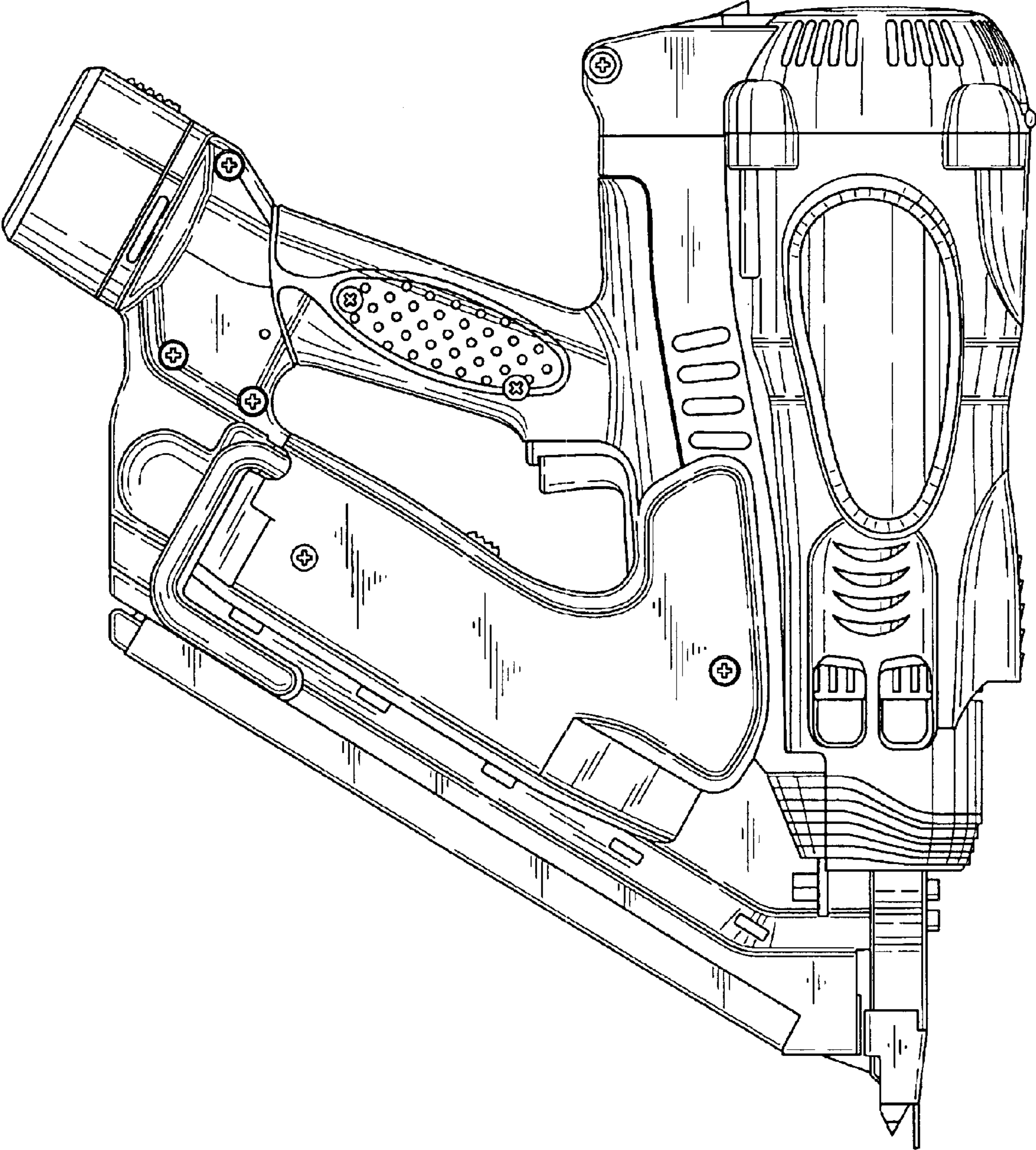

FIG. 4

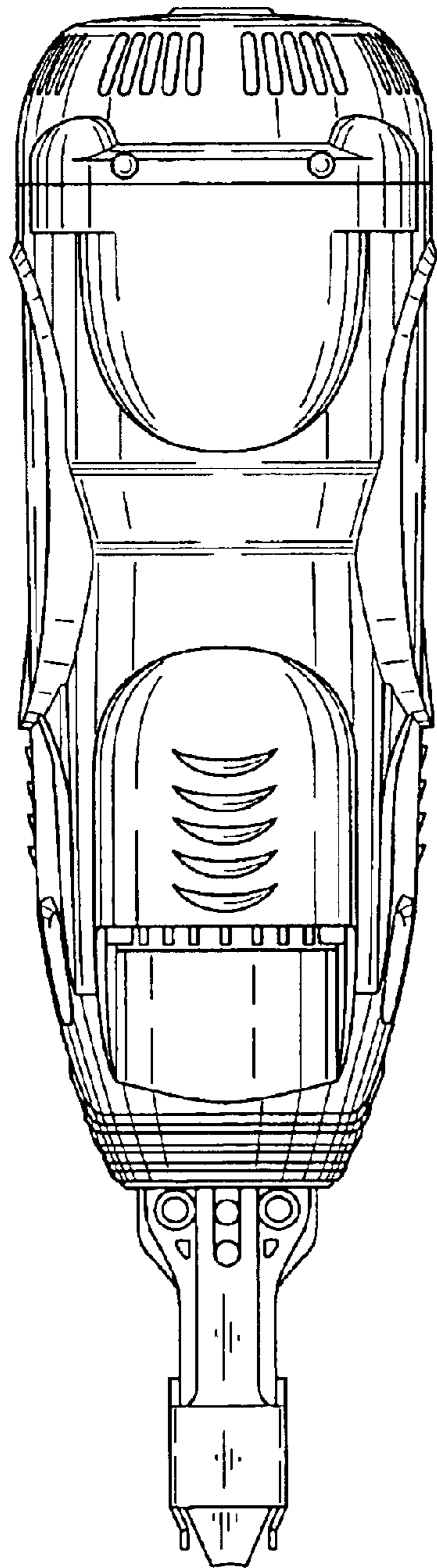

FIG. 5

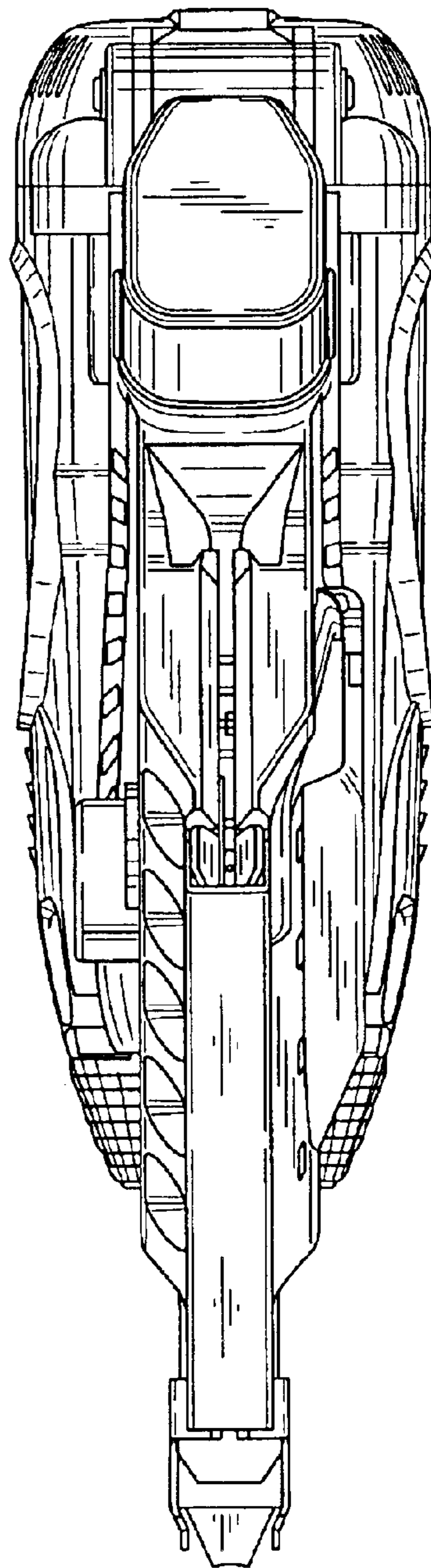

FIG. 6

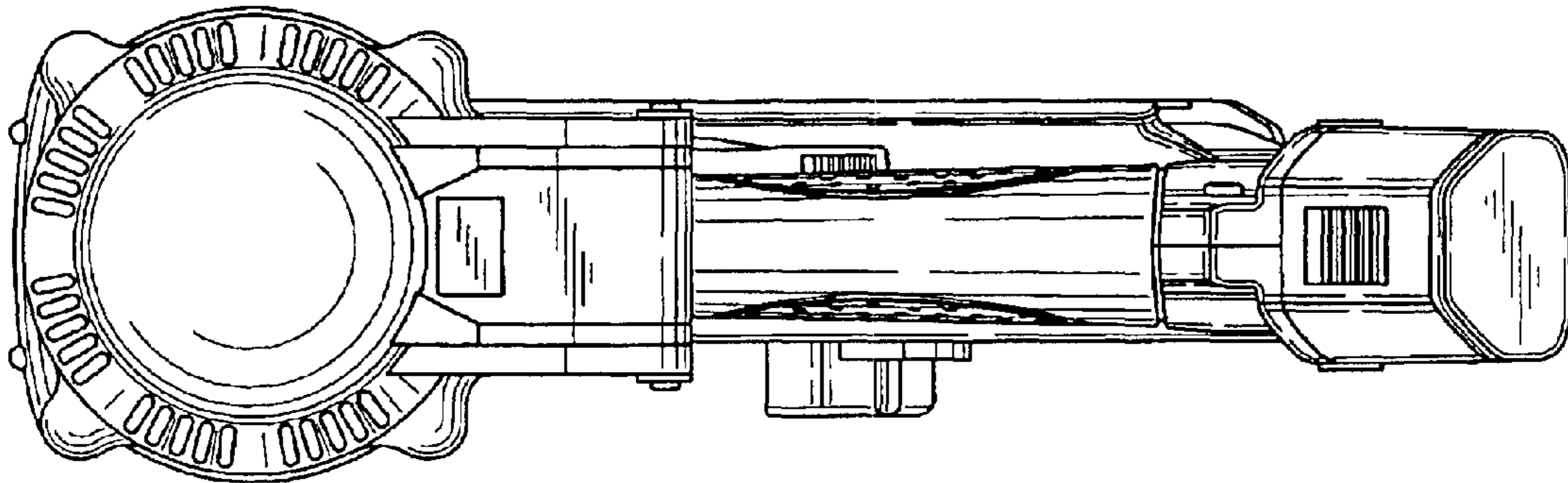

FIG. 7

