

US00D497296S1

(12) **United States Design Patent**
Krondorfer et al.

(10) **Patent No.:** **US D497,296 S**

(45) **Date of Patent:** **** Oct. 19, 2004**

(54) **GRINDER**

(75) Inventors: **Harald Krondorfer**, Ludwigsburg (DE); **Markus Heckmann**, Leinfelden (DE); **Hughes Roudiere**, Hong Kong (CN); **Klaus Schoen**, Altbach (DE)

(73) Assignee: **Robert Bosch GmbH**, Stuttgart (DE)

(**) Term: **14 Years**

(21) Appl. No.: **29/174,466**

(22) Filed: **Jan. 17, 2003**

(30) **Foreign Application Priority Data**

Jul. 22, 2002 (DE) 4 02 06 014

(51) **LOC (7) Cl.** **08-01**

(52) **U.S. Cl.** **D8/62**

(58) **Field of Search** D8/61, 62, 67, D8/69; 173/170, 171; 310/50; 451/344, 351, 352, 353, 354, 355, 356, 357, 358, 359, 451

(56) **References Cited**

U.S. PATENT DOCUMENTS

D295,824 S * 5/1988 Hoshino et al. D8/62
D297,907 S * 10/1988 Hoshimo et al. D8/62
5,201,146 A * 4/1993 Fushiya 451/358
D351,772 S * 10/1994 Price D8/62

5,398,454 A * 3/1995 Berner 451/357
D408,244 S * 4/1999 Price D8/62
D433,906 S * 11/2000 Heun D8/62
6,306,024 B1 * 10/2001 Kai et al. 451/357
D450,989 S * 11/2001 Schoen D8/62
D453,098 S * 1/2002 Pretzell D8/62
D468,179 S * 1/2003 Hayakawa et al. D8/62
6,527,630 B2 * 3/2003 Mannsperger et al. 451/344
D479,452 S * 9/2003 Cho D8/62

* cited by examiner

Primary Examiner—Robert M. Spear

Assistant Examiner—Elizabeth Albert

(74) *Attorney, Agent, or Firm*—Michael J. Striker

(57) **CLAIM**

The ornamental design for a grinder, as shown and described.

DESCRIPTION

FIG. 1 is a top, front and right side perspective view of a grinder showing our new design;

FIG. 2 is a left side perspective view thereof;

FIG. 3 is a right side perspective view thereof;

FIG. 4 is a top perspective view thereof;

FIG. 5 is a bottom perspective view thereof;

FIG. 6 is a front perspective view thereof; and,

FIG. 7 is a rear perspective view thereof.

1 Claim, 7 Drawing Sheets

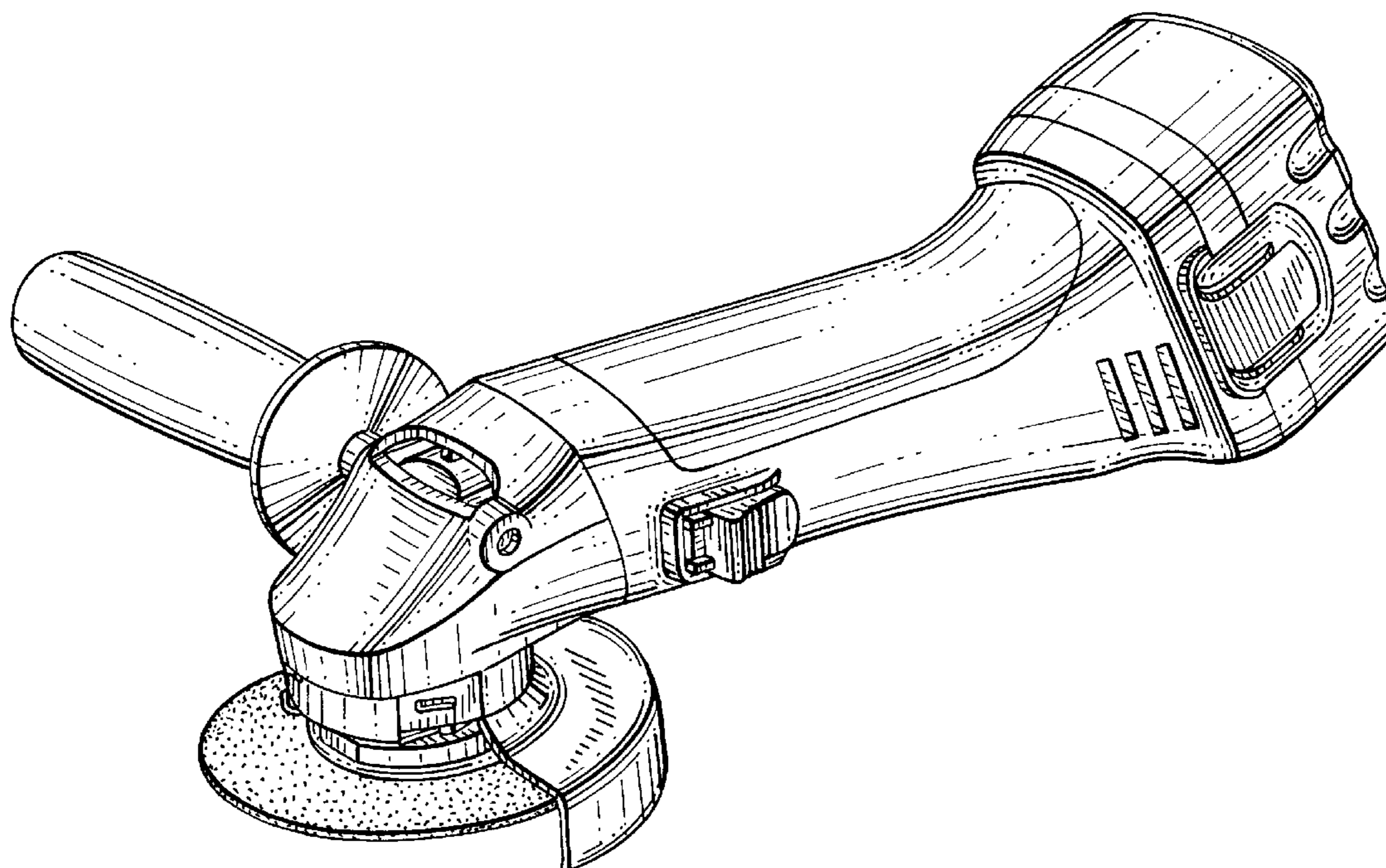

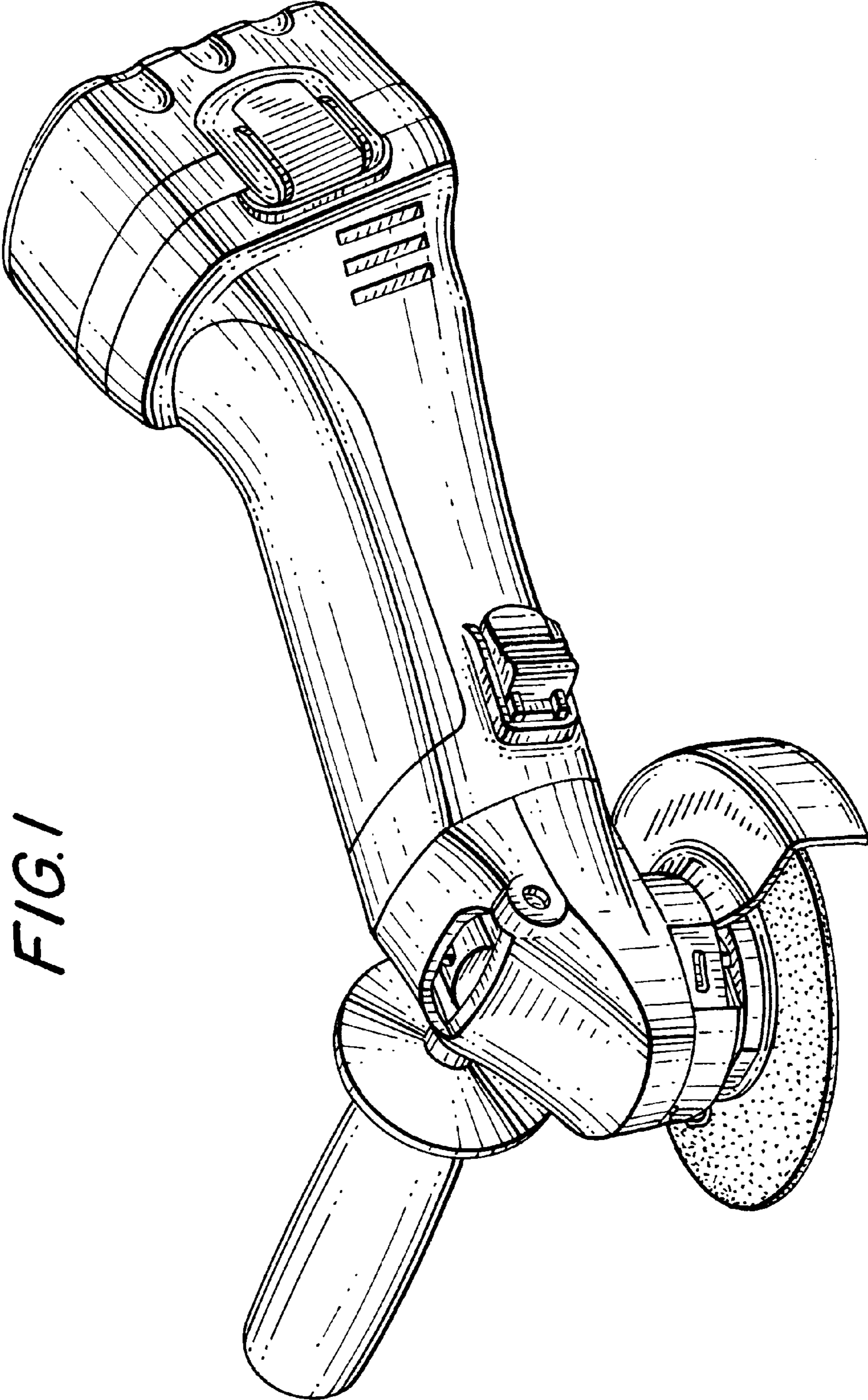
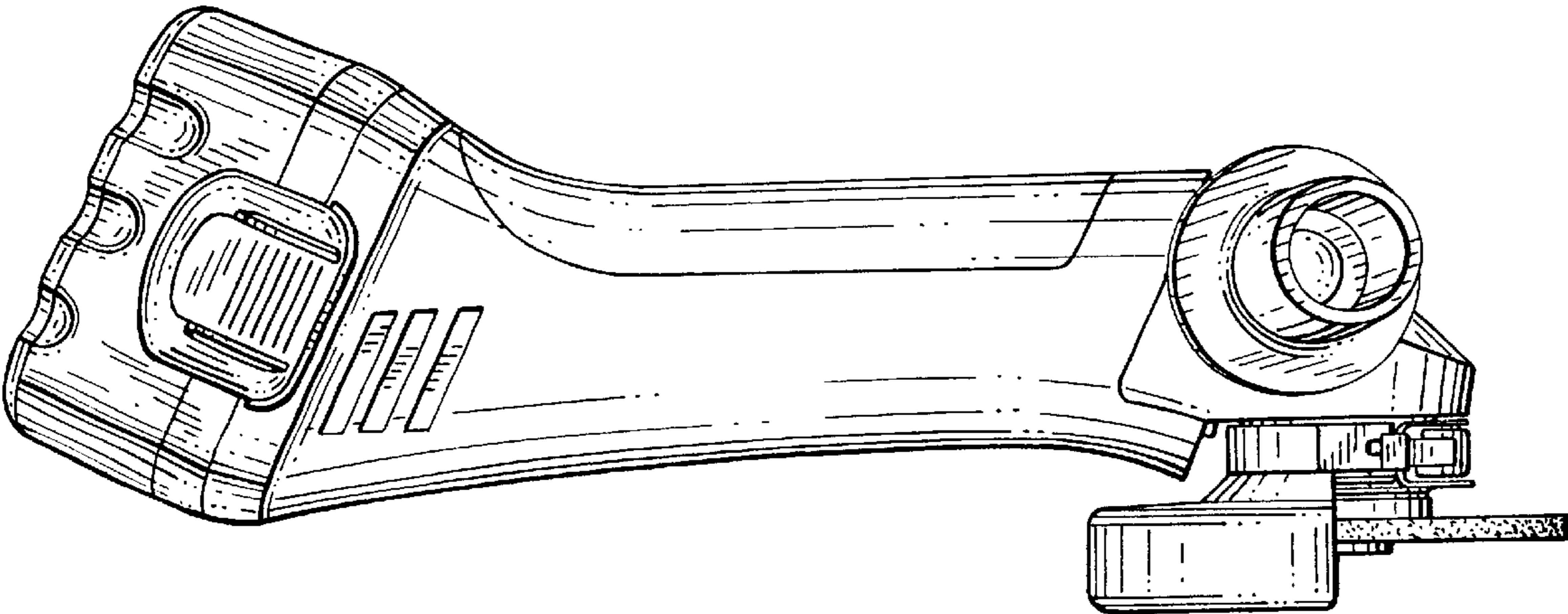

FIG. 1

FIG. 2



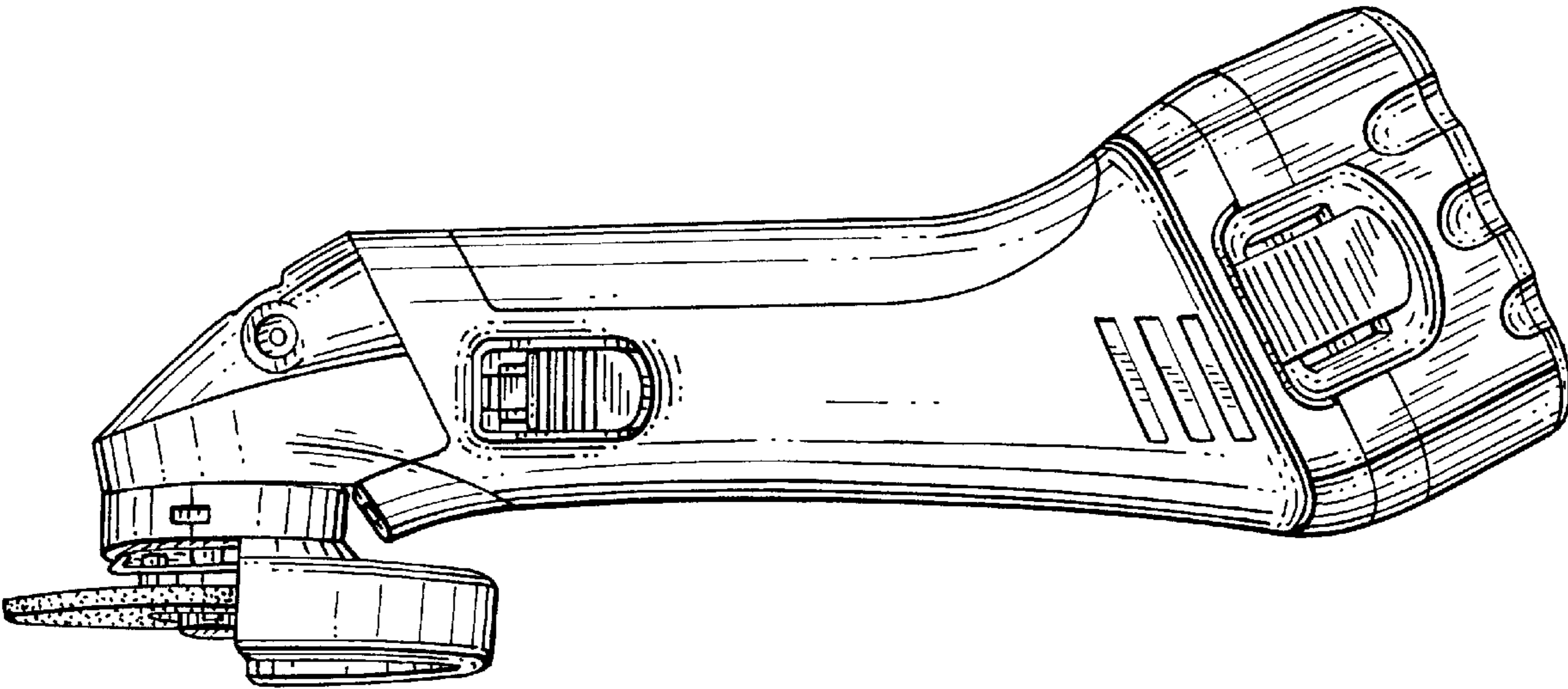

FIG. 3

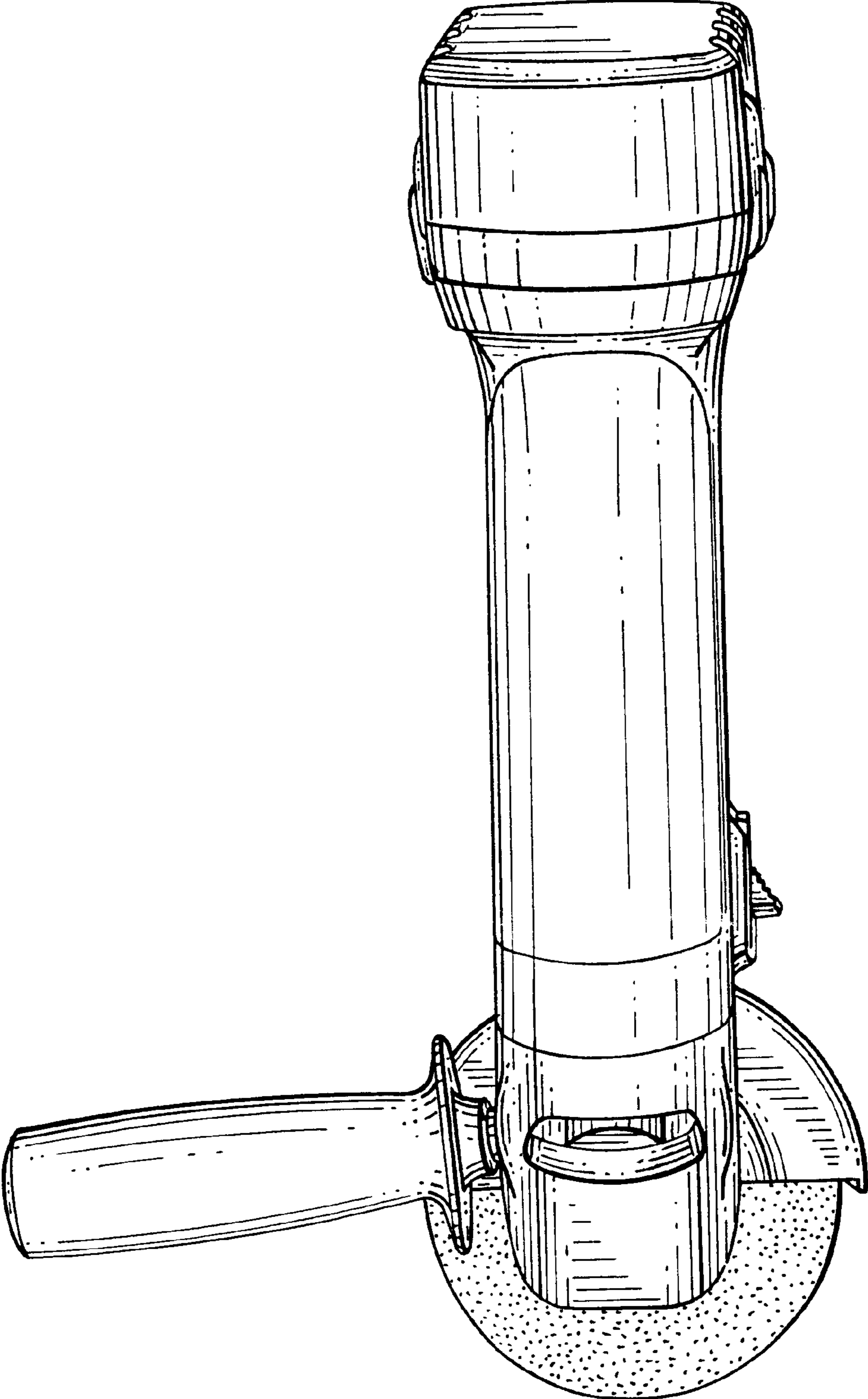

FIG. 4

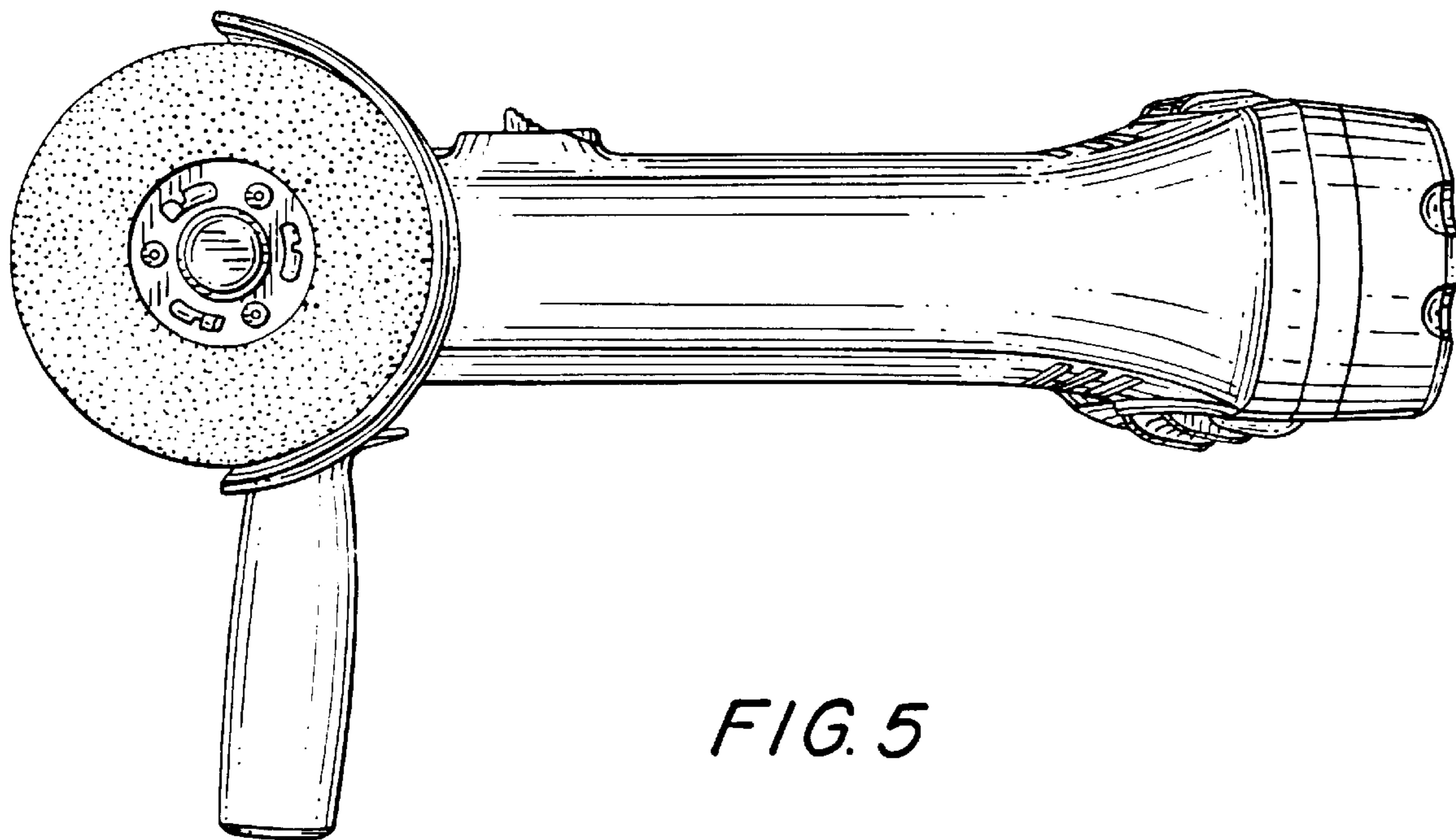

FIG. 5

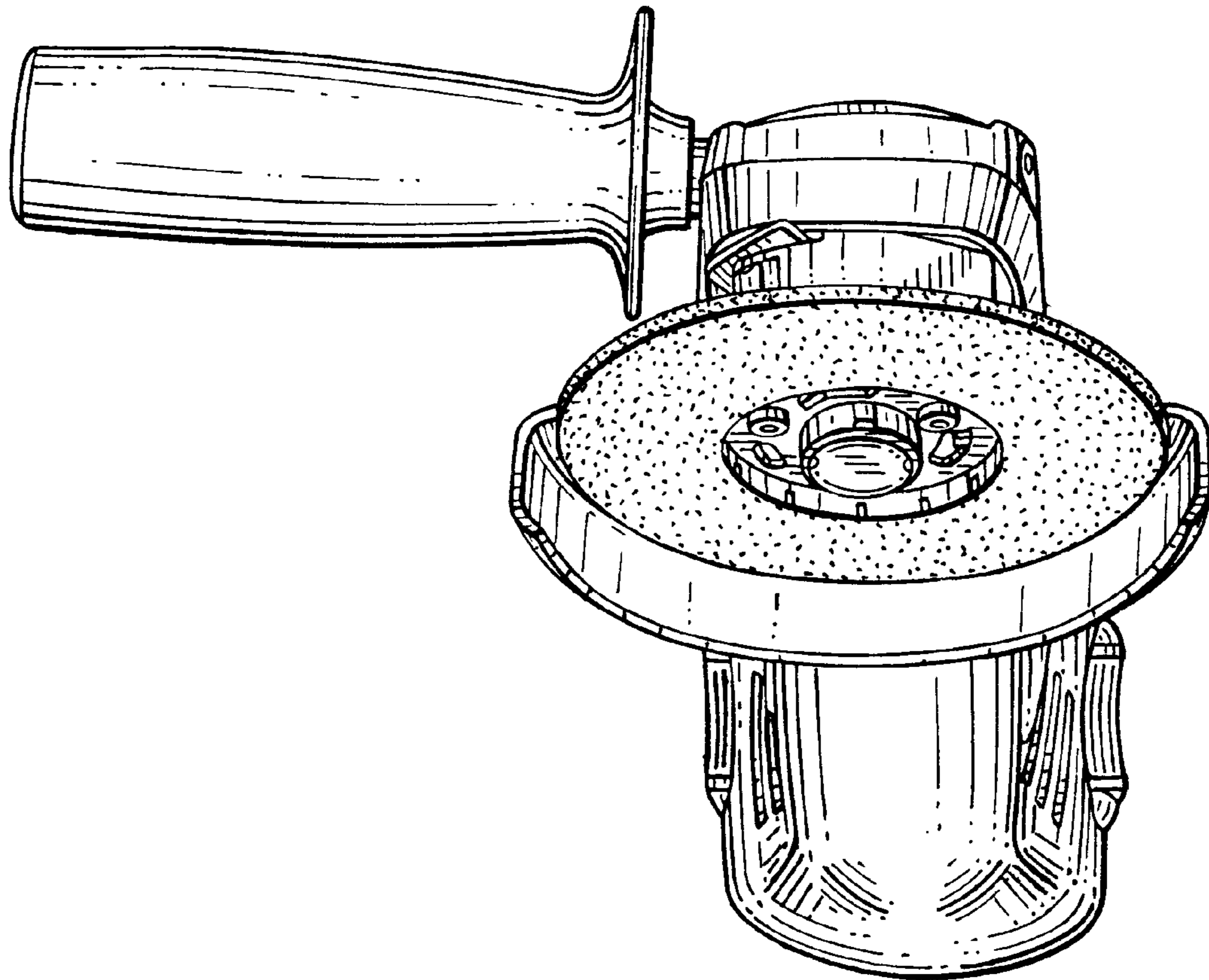

FIG. 6

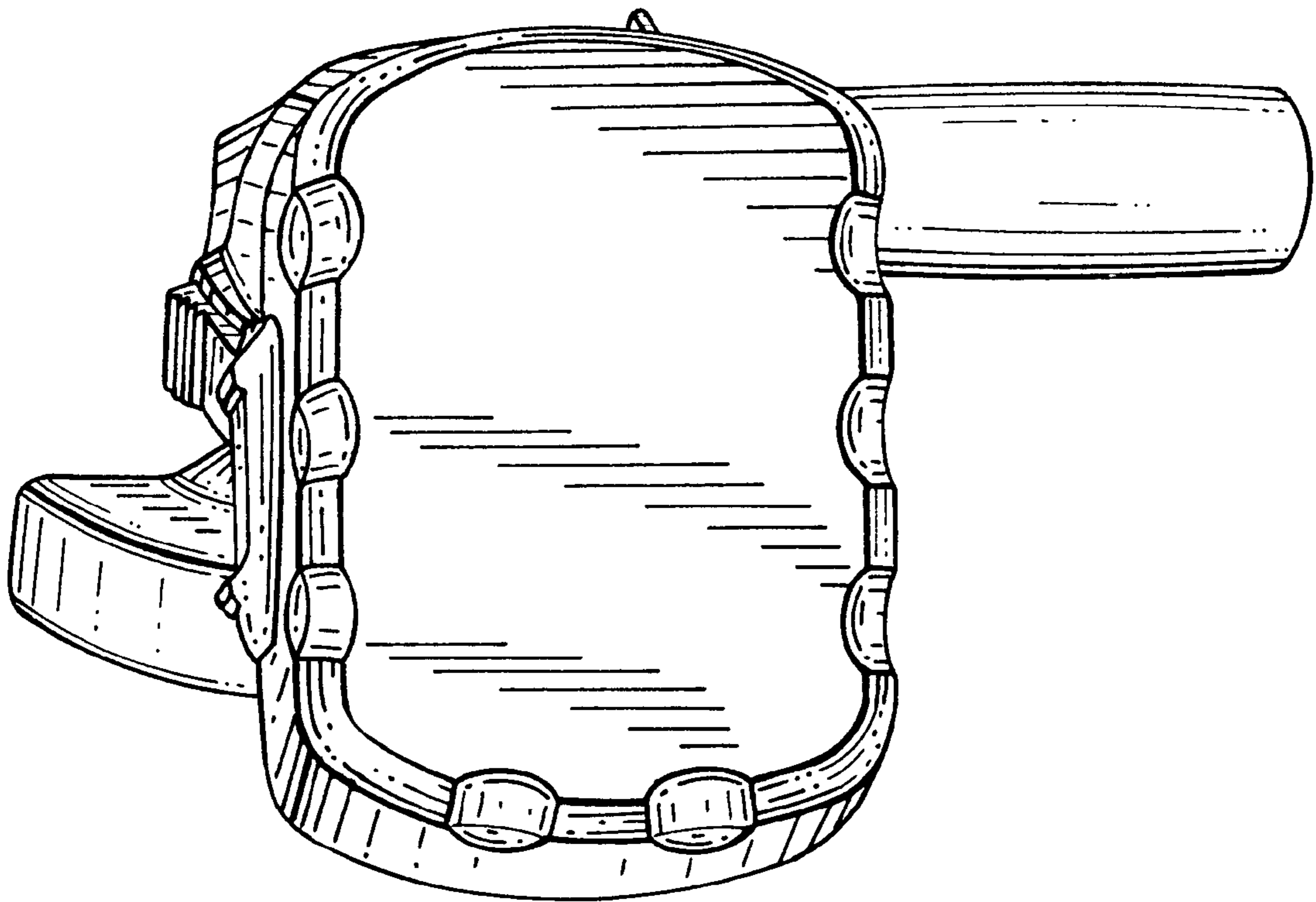

FIG. 7