



US00D497182S1

(12) **United States Design Patent** (10) Patent No.: **US D497,182 S**
McCartney (45) Date of Patent: **** Oct. 12, 2004**

(54) **TEACHING APPARATUS BLOCK**
 (75) Inventor: **Christopher John McCartney**, Port Elizabeth (ZA)
 (73) Assignee: **Somerset Educational (Pty) Limited**, Somerset East (ZA)
 (**) Term: **14 Years**

3,797,134 A * 3/1974 Wingerd 434/216
 4,032,155 A * 6/1977 Thomas 273/156
 4,228,628 A * 10/1980 Schlomann 52/438
 4,602,908 A * 7/1986 Kroeber 446/128
 4,719,738 A * 1/1988 Lee 52/607
 4,731,279 A * 3/1988 Isshiki 428/159
 D310,421 S * 9/1990 Nauseda et al. D25/113
 D338,243 S * 8/1993 Underwood D21/391
 6,206,701 B1 * 3/2001 Kohlberg 434/195

* cited by examiner

(21) Appl. No.: **29/181,217**
 (22) Filed: **May 8, 2003**

Primary Examiner—Joel Sincavage
Assistant Examiner—Elizabeth Albert
 (74) *Attorney, Agent, or Firm*—Young & Thompson

(51) **LOC (7) Cl.** **19-07**
 (52) **U.S. Cl.** **D19/59**
 (58) **Field of Search** D19/59, 60, 61,
 D19/62, 64; D21/6, 491, 500; D25/113,
 114, 115, 116, 117; 52/561, 566, 596, 598,
 606, 607, 749.13; 434/72, 74, 189, 208;
 446/122

(57) **CLAIM**

The ornamental design for a teaching apparatus block, as shown and described.

DESCRIPTION

FIG. 1 is a top plan view of the teaching apparatus block showing my new design;
 FIG. 2 is a side elevation view of FIG. 1, the opposite side being identical;
 FIG. 3 is a front elevation of FIG. 1, the opposite side being identical;
 FIG. 4 is a bottom plan view FIG. 1;
 FIG. 5 is an isometric view of FIG. 1 from the top; and,
 FIG. 6 is an isometric view of FIG. 1 from the bottom.

(56) **References Cited**

U.S. PATENT DOCUMENTS

1,308,254 A * 7/1919 Otto 446/122
 1,836,870 A * 12/1931 Quer 434/195
 2,012,798 A * 8/1935 Whittler 501/81
 2,093,341 A * 9/1937 Reiche 446/104
 3,235,975 A * 2/1966 Pierson 434/189
 3,696,533 A * 10/1972 Mortensen 434/208
 3,768,178 A * 10/1973 Glassman 434/190

1 Claim, 1 Drawing Sheet

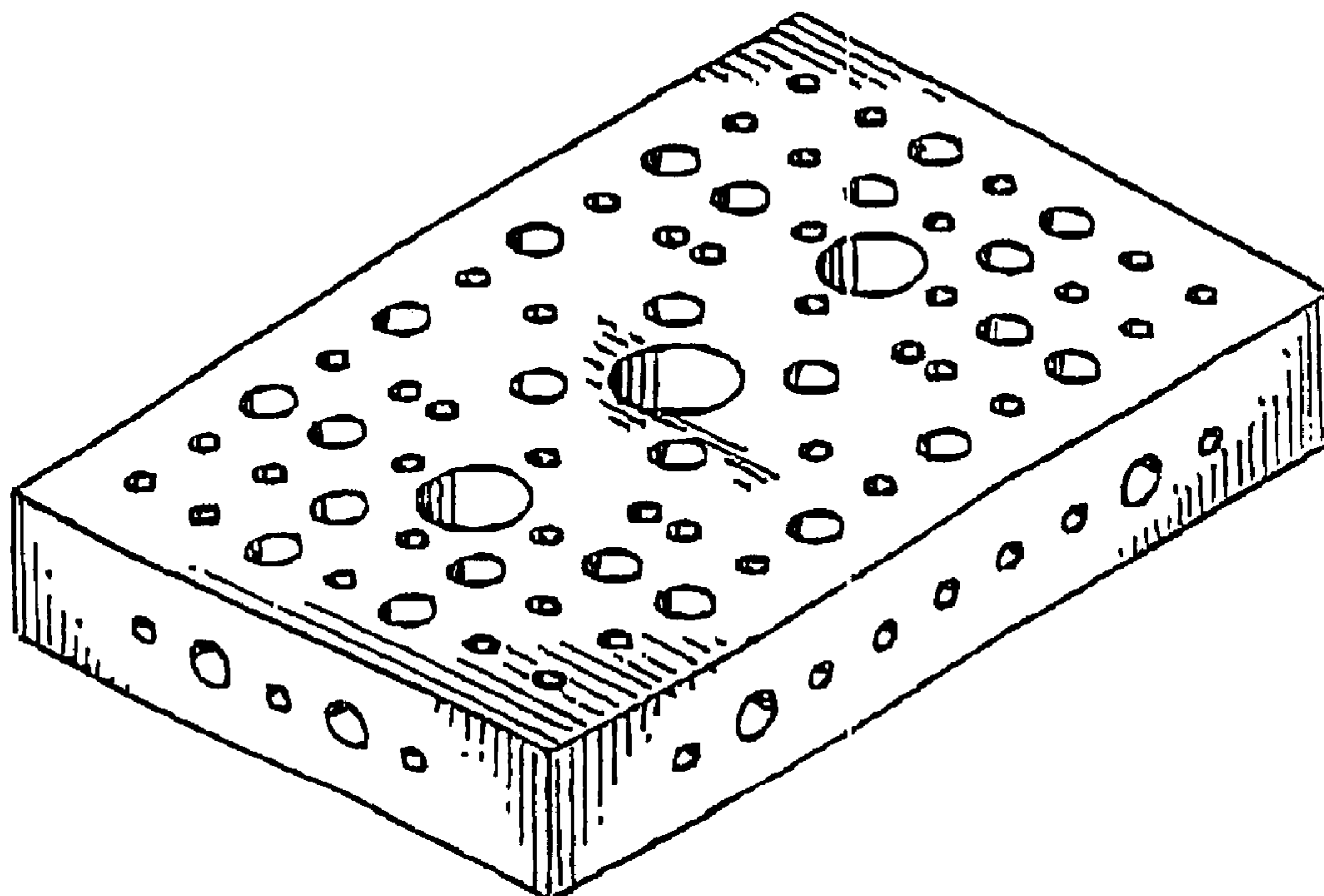

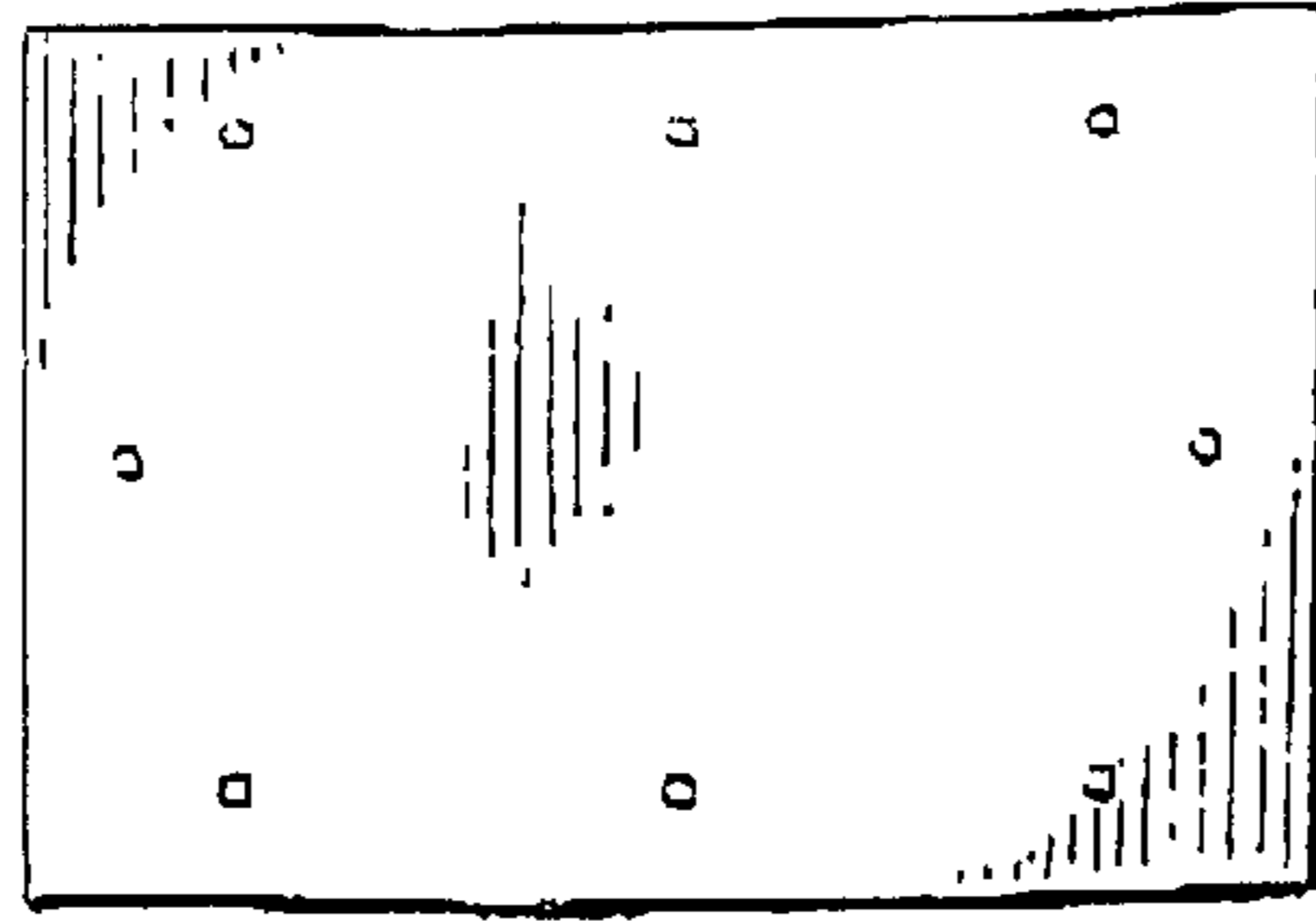

FIGURE 4

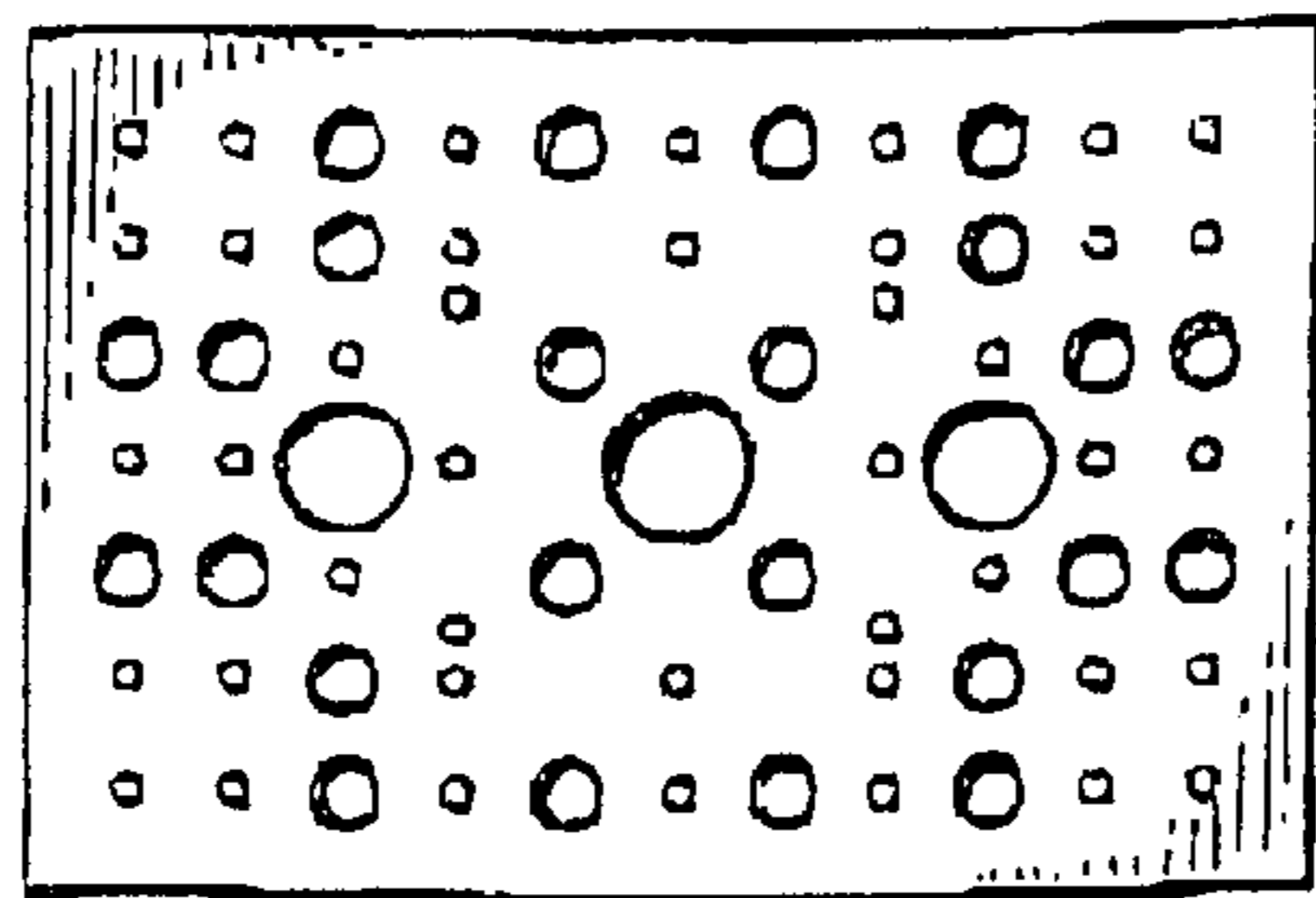

FIGURE 1

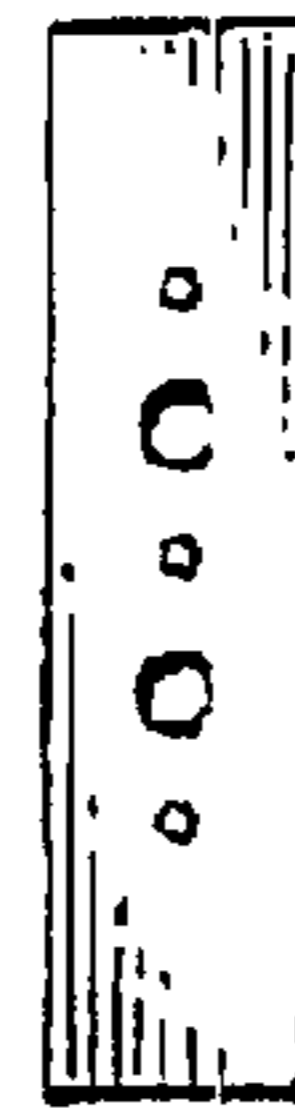

FIGURE 2



FIGURE 3

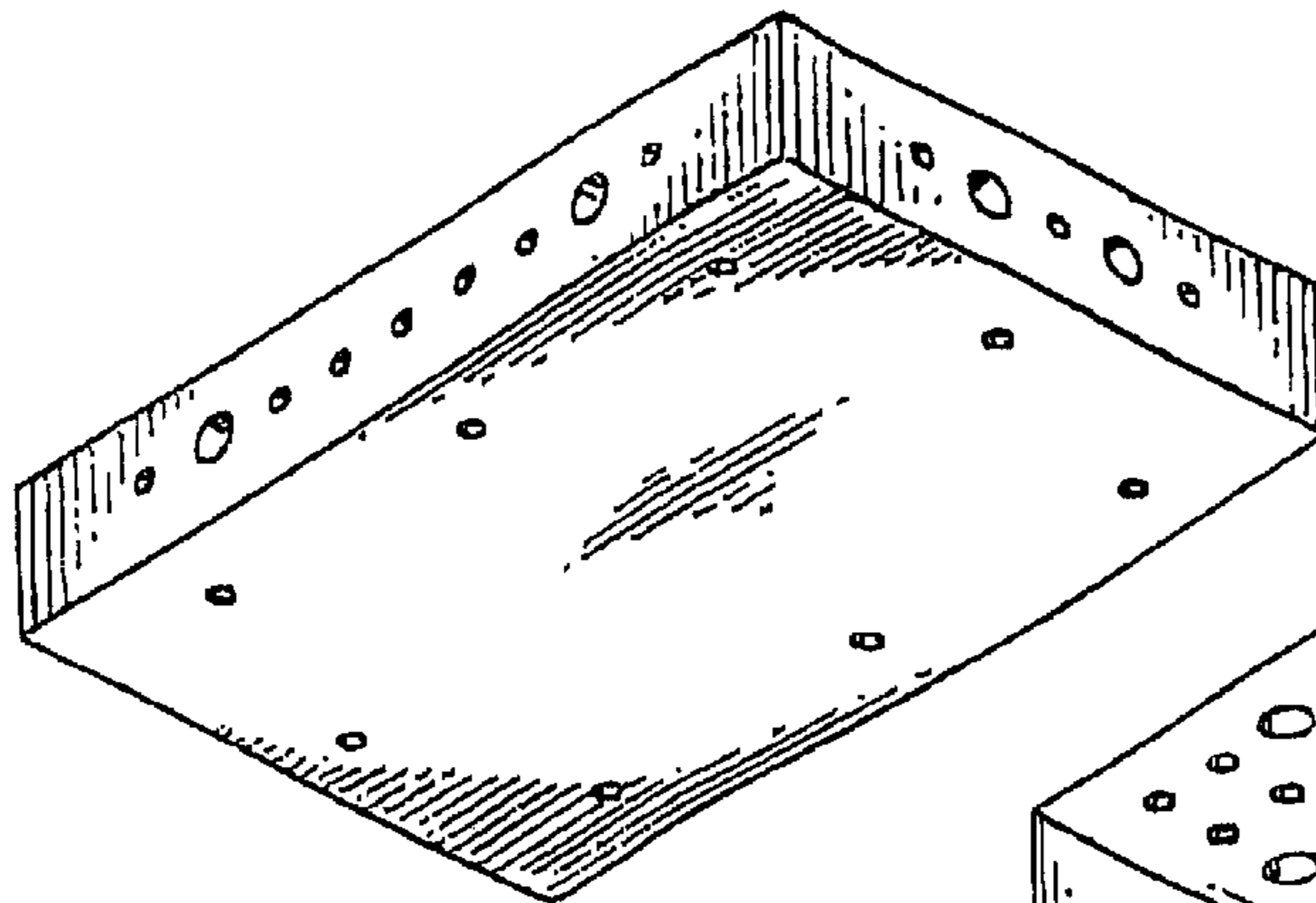

FIGURE 6

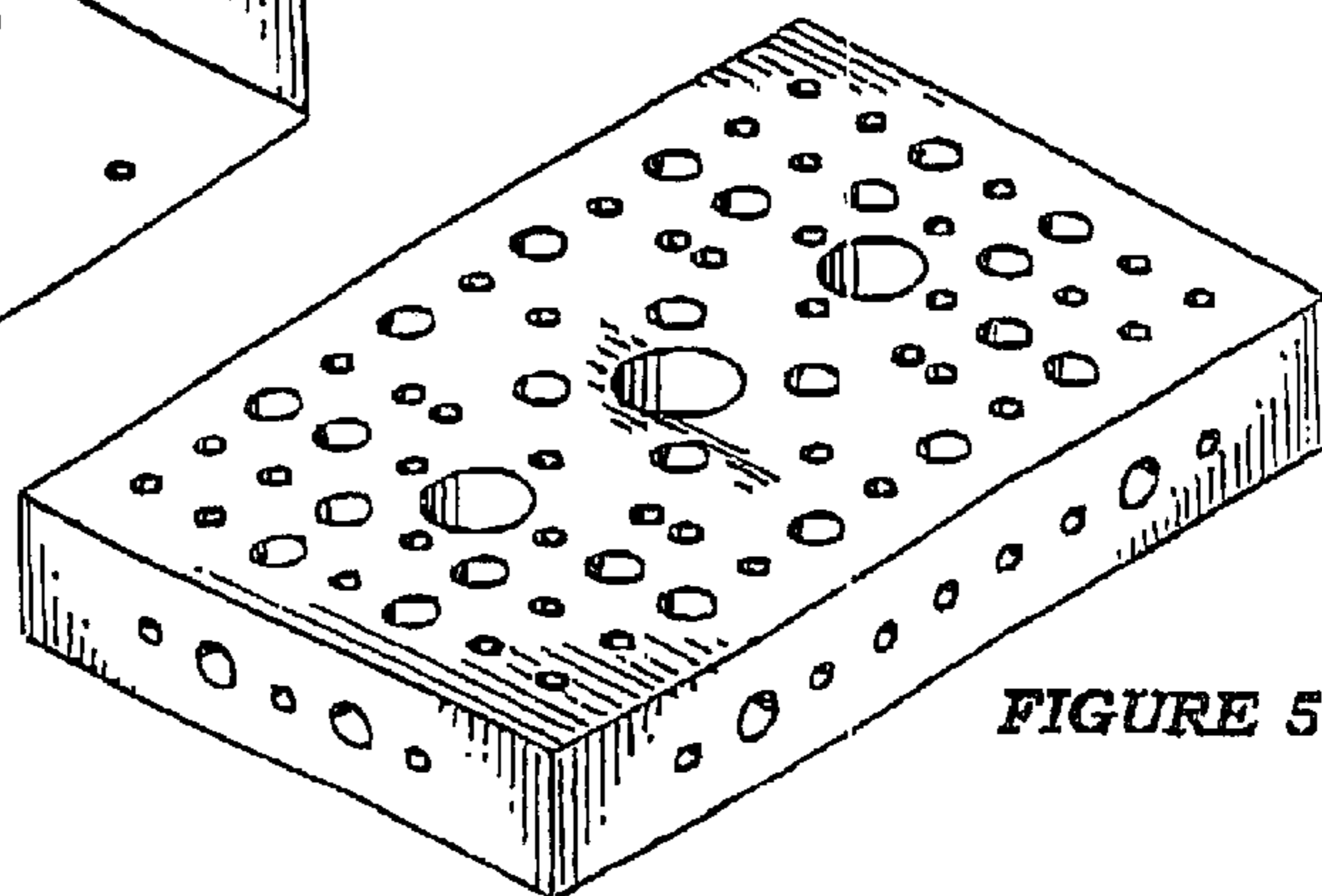

FIGURE 5